



Fall 2010

Table of Contents



ENROLLMENT INFORMATION	
Dates to Know.....	2
Admissions	3
How to Enroll in Classes	4
Enroll Online.....	5
How to Enroll.....	6
Consejos Para Inscribe En Las Clases	6
Ռ՞Վ Կարող է դիմել ընդունվելու համար	7
Matriculation	8
How To Plan Your Schedule.....	9
Adds, Drops, Etc	10
Educational for Sustainable Leadership	11, 122
Degree & Certificate Program	22
Major Codes.....	23
LACC Parking	123
FINANCIAL AID INFORMATION	12
Fee Schedule: Fall 2010	13
Fee Waiver (BOG).....	91
CLASS INFORMATION	
How to Read the Class Schedule	2
Prerequisites, Co-requisites & Waivers	8
Online Line Classes for Fall 2010.....	14
Short Term Classes.....	15
ITV Classes (The Weekend College)	19
Ralph Bunche Scholar Program	20
Supplemental Instruction (SI).....	21
Final Exam Schedule	26
Fall Class Listings.....	27
ACT - For Working Adults	93
Credit/No Credit	109
GRADUATION & TRANSFER INFORMATION	
Matriculation.....	8
UC & CSU Transfer Requirements (IGETC)	94
Associate Degree General Education Requirements.....	97
Graduation Requirements.....	96
LACC Transfer Center	105
COLLEGE POLICIES	
Academic.....	107
Grading, Probation, Dismissal, Appeal, Scholarship Standards, Attendance, Auditing, Catalogue, Credit by Exam, Dean’s List, Dropping Classes/Withdrawal, Incomplete Grades, English Proficiency, Open Enrollment, Course Repetition, Study Load	
General	110
Directory Information, Compliance Procedures, Fee Refunds, Health Fee Waivers, Non-Discrimination Notice, Payment Information, Sex Offenders	
Student.....	111
Drugs, Code of Conduct, Discipline Procedures, Grievance Procedures, Student Right to Know, Ombudsperson, Sexual Harassment	
MAP & LEGEND	Inside Back Cover



Dates to Know FALL 2010 SEMESTER

FALL 2010 REGISTRATION

Application for Admission Available	Year Round		
PRIORITY Registration Begins	Monday	May	3
CONTINUING Student	Thursday	May	6
NEW Student Registration Begins	Tuesday	June	1

FALL SEMESTER 2010- 8/30/10 thru 12/19/10

Monday – Thursday Classes Begin	Monday	August	30
Friday Classes Begin	Friday	September	3
Saturday Classes Begin	Saturday	September	4
Final Exam Week	Sunday	December	12
	thru Saturday	December	18

DAYS COLLEGE IS CLOSED

Labor Day	Monday	September	6
Veterans Day	Thursday	November	11
Thanksgiving Holiday	Thursday	November	25
	and Friday	November	26

DEADLINES (LAST DAY TO)

DROP With a Refund	Monday	September	13
DROP Without a Fee	Monday	September	13
ADD (Traditional) Classes	Saturday	September	11
DROP Classes from your Permanent Record Without a "W"			
	Friday	September	24
	(via WEB) Sunday	September	26
FILE for Credit/No Credit Grades			
	Friday	September	24
DROP Classes With a "W"	Friday	November	19
	(via WEB) Sunday	November	21
FILING Period for June 2011 Graduation			
	Monday	September	20
	thru Friday	December	3

HOW TO READ THE CLASS SCHEDULE

COURSE CLASSIFICATIONS

- UC** Acceptable at all branches of the University of California.
- CSU** Baccalaureate-transferable to the California State Universities and colleges as well as other four-year-colleges and universities.
- A** Associate degree level-courses which may be used for graduation requirements.

- NDC** Non-degree courses, reparatory and developmental; may not be used toward graduation requirements.
- NC** Remedial and developmental; may not be used toward graduation requirement.
- CAN** California Articulation Number- course accepted at any campus where this number is indicated.
- RPT** Designates the number of times a class may be repeated.

BUILDING NAME ABBREVIATIONS

- | | |
|---|---|
| AD Caesar Chavez Administration Building | GRIFFITH Griffith Park |
| BUNG Bungalow | HH Holmes Hall |
| CHEM Chemistry Building | JH Jefferson Hall |
| CC Communications Center | MLK Martin Luther King Jr. Library |
| CH Clausen Hall | LS Life Sciences |
| CUB Cub Center | MG Men's Gym |
| DH DaVinci Hall | RT Radiologic Technology |
| FIELD Off Campus | THEA Camino Theater |

EXAMPLE:

Course Name:
(or subject)

Complete prerequisite classes before enrolling in this class (note: prerequisites are now being electronically enforced)

Section or ticket number

Evening classes are Bold

ACCOUNTING 22 - BOOKKEEPING AND ACCOUNTING 11(UC:CSU) - 3 UNITS

NOTE: Accounting 22 students must also enroll in Accounting at the same hour and with the same instructor as Accounting 22.

Prerequisite: 1) Prior successful completion of Accounting 21 and 41 and 2) Concurrent enrollment in Accounting 42 at the same hour and with the same instructor as Accounting 22. Credit allowed for only Accounting 1 or the combination of Accounting 21 with 41 and 22 with 42.

0114	8:00 - 9:00	MWF	E.C. Ayuyao	AD 207
0115	8:00 - 11:00	Sat	L.E. Gogg	JH 102

Time class meets

Day class meets

Instructor Building & rm #

(TBA = to be assigned)

(STAFF = instructor to be arranged)

BASIC SKILLS ENROLLMENT LIMITATION

TITLE 5, CALIFORNIA CODE OF REGULATIONS, LIMITS STUDENT FROM TAKING MORE THAT 30 UNITS OF "REMEDIAL" COURSE WORK, WHICH IS DEFINED AS "NONDEGREE-APPLICABLE BASIC SKILLS COURSES." EFFECTIVE WINTER 2010, THE COLLEGE'S REGISTRATION SYSTEM WILL PREVENT STUDENTS, WHO HAVE EXCEEDED THIS LIMIT, FROM ENROLLING IN ADDITIONAL BASIC SKILLS COURSES. HOWEVER A STUDENT, WHO HAS REACHED THIS LIMIT BUT ENROLLS IN A CREDIT OR NONCREDIT ENGLISH AS A SECOND LANGUAGE (ESL) COURSE, WILL BE ALLOWED TO ENROLL IN ADDITIONAL BASIC SKILLS COURSES. STUDENTS WITH A LEARNING DISABILITY MAY REQUEST AN EXEMPTION THROUGH THE DISABLED STUDENT PROGRAMS AND SERVICES (DSPS) OFFICE. ALSO, THIS LIMITATION DOES NOT APPLY TO ENROLLMENT IN NONCREDIT BASIC SKILLS COURSES. THIS SCHEDULE IS AVAILABLE IN ALTERNATE FORMAT ON REQUEST.

Admissions



WHO MAY APPLY FOR ADMISSIONS?

- A high school graduate, or
- A person who is eighteen years of age or older who can benefit from instruction, or
- A student under eighteen years of age and not a high school graduate, under special programs.

HOW DO I APPLY?

Apply Online at www.lacitycollege.edu – click “Apply for Admissions”.
All new students are encouraged to apply online.

High school students over the age of 13 may also apply online. However a Supplemental Application for Admission of Students in Grades K-12 is also required. This form can be obtained from your high school counselor. **AB 540 students must apply in person in the Admissions Office.** High School students must re-apply every semester and are limited to 11 units per semester (7 units in winter session).

International Students must complete their admissions process through the International Student Center in the Cub Center. For more information, visit their web page at www.lacitycollege.edu/services/intnlctr/index.htm

Paper applications are available at the Student Assistance Center in AD 105.

MUST I BE A CALIFORNIA RESIDENT?

No. However, to attend any of the Los Angeles Community College District colleges as a California resident, for tuition purposes, students are required to have a status that allows them to establish California residence prior to the Residence Determination Date. The “Residence Determination Date” is that day immediately preceding the opening day of instruction of the semester, summer session or winter inter session.

ACCREDITATION & PROFESSIONAL PROGRAM APPROVALS

Los Angeles City College, a California public, tax-supported community college, is accredited by the Accrediting Commission for Community and Junior Colleges of the Western Association of Schools and Colleges (3402 Mendocino Avenue, Santa Rosa, CA, 95403; [707] 569-9177), an institutional accrediting body recognized by the Commission on Recognition of Postsecondary Accreditation and the United States Department of Education. Los Angeles City College programs are also accredited by the American Dental Association (Dental Laboratory Technician) and the American Medical Association (Radiologic Technology) and the Commission on Dietetic Education of the American Dietetic Association (Dietetic Technician).

ACCURACY STATEMENT

The Los Angeles Community College District and Los Angeles City College have made every effort to make the Schedule of Classes accurate and may, without notice, change general information, courses, or programs offered. The reasons for change may include student enrollment, level of funding, or other issues decided by the District or College. The District and College also reserve the right to add to, change, or cancel any rules, regulations, policies, and procedures as provided by law.

LIMITED ENGLISH PROFICIENCY

Occupational Education Classes are open to all students. Although the lack of proficiency in English is no barrier to enrollment in occupational education courses, it is suggested

the students deficient in English utilize the services of the college that are provided for persons who are limited in English proficiency or have English as a Second Language.

Contamos con cursos vocacionales en distintas ramas de trabajo. Todos los cursos están disponibles a las personas que no dominan el idioma inglés con fluidez. No tener conocimientos básicos de inglés no debe ser un impedimento para matricularse en dichos cursos. Los servicios del colegio están disponibles para personas que hablan inglés como segundo lenguaje.

ԱՍԻՄԻԼԱԿԱԿ ԱՆԳԼԵՐԵՆ ՏԻՐԱՊԵՏԵԼՈՒ ԴԵՊՁՈՒՄ
 Մասնագիտական կրթության դասերը բաց են բոլոր ուսանողների համար: Անգլերենի սահմանափակ տիրապետումը արգելք չի համդիսանում ընդգրկվելու մասնագիտական դասերի մեջ: Անգլերենից թույլ ուսանողներին առաջարկվում է օգտվել քոլեջի ծառայություններից, որոնք նախատեսված են այն ուսանողների համար, որոնց անգլերենը սահմանափակ է կամ երկրորդ լեզուն է ՌՐՍԼՏ:

MATERIALS IN ALTERNATIVE FORMATS

Students with verifiable disabilities who require alternate formats of college publications and resources should contact the Vice President of Student Services (323) 953-4000 ext. 2460. The College will provide information in alternate text formats upon request in the timeliest manner possible.



How To Enroll in Classes

NEW & RETURNING STUDENTS

A “New Student” is one who has never taken classes at LACC.

A “Returning Student” is one who has had a break of more than two semesters between enrollments at LACC.

• Complete Application

Apply Online at www.lacitycollege.edu or obtain a paper application from Student Assistance Center, AD 105.

• Get Registration Appointment

(Appointment to Enroll in Classes)

Online Application – All new students are encouraged to apply online. Before you begin this application, if you do not have an e-mail account, we suggest you get one through one of the web-sites that offer free e-mail accounts (ie. Yahoo, Hot-mail).

After you submit your application, you will be e-mailed your registration appointment. You may register on or anytime after your appointment date / time. You can register for classes online or through STEP until the first day of class. Once classes begin, you may have to obtain an add permit from the instructor.

Paper Applications are available in AD 105.

• Make Assessment Appointment & Complete the Process

The LACC assessment (placement test) helps to determine at which class level you are most likely to succeed. THIS IS NOT AN ADMISSIONS TEST AND YOU CAN NOT FAIL. However, the results are required by most departments to enroll in certain classes. A special assessment will be administered to student whose native language is not English. Because placement results may not be available for up to 3 days after you have taken the test, we encourage you to do so as early as possible. Test dates are available on page 151 of this schedule. Additional information and a sample test are provided at www.lacitycollege.edu (click Student Services, click Assessment). Make your appointment at the Assessment Office, AD103.

• Apply for Financial Aid

To receive the best aid package for 2010-2011, new and returning students should file the Free Application for Federal Aid (FAFSA) between January 1, 2010 and March 2, 2011. Students who did not file a FAFSA prior to March 2, 2010 are urged to file their FAFSA as soon as possible. The FAFSA form is available in the Financial Aid Office, CH 111-A or online at www.fafsa.ed.gov. The Financial Aid Office provides assistance in completing the necessary forms to apply for financial aid.

• Attend in Orientation

Orientation introduces you to the campus resources, support services and college programs which are available to help you make better, more informed educational and career choices. Students participating in Orientation will receive an education plan and priority registration.

• Register for Classes

Enroll in classes using the automated phone system STEP (see page 9) or Online at www.lacitycollege.edu (click Admissions). Once classes begin, you may have to get an “Add Permit” from the instructor to enroll in a class.

• Pay Fees

You may pay with a credit card when you register with STEP or Online. If you do not pay for classes at that time, you must do so prior to the end of the semester. You may pay with cash, check or credit card at the Business Office, AD11.

• Get Student ID

Once you have your fee receipt, be sure to go to the Cub Card Office, AD105, to pick up your student ID card.

CONTINUING STUDENTS

A “Continuing Student” is one who attended classes at LACC in one of the two prior semesters.

• Receive Registration Appointment

Continuing Students will receive a phone call and/or an e-mail with their priority registration appointment date/time. Student may register at the date/time indicated or any day thereafter.

• Apply for Financial Aid

To receive the best aid package for 2010-2011, continuing students should file the Free Application for Federal Aid (FAFSA) between January 1, 2010 and March 2, 2010. Students who did not file a FAFSA prior to March 2, 2010 are urged to file their FAFSA as soon as possible. The FAFSA form is available in the Financial Aid Office, CH111A or online at www.fafsa.ed.gov. The Financial Aid Office provides assistance in completing the necessary forms to apply for financial aid.

• Visit a Counselor

See a counselor well in advance of registration. Make sure you are selecting the correct classes to reach your academic goal whether it be a degree, certificate, university transfer or other professional/personal goal.

• Register for Classes

Enroll in classes using on-line at www.lacitycollege.edu (click Admissions)

• Pay Fees

You may pay with a credit card when you register. If you do not pay for classes at that time, you must do so prior to the end of the semester. You may pay with cash, check or credit card at the Business Office, AD11

FOR MORE INFORMATION ON:



Enrolling online 5



Matriculation, Prerequisites and Co-Requisites 14

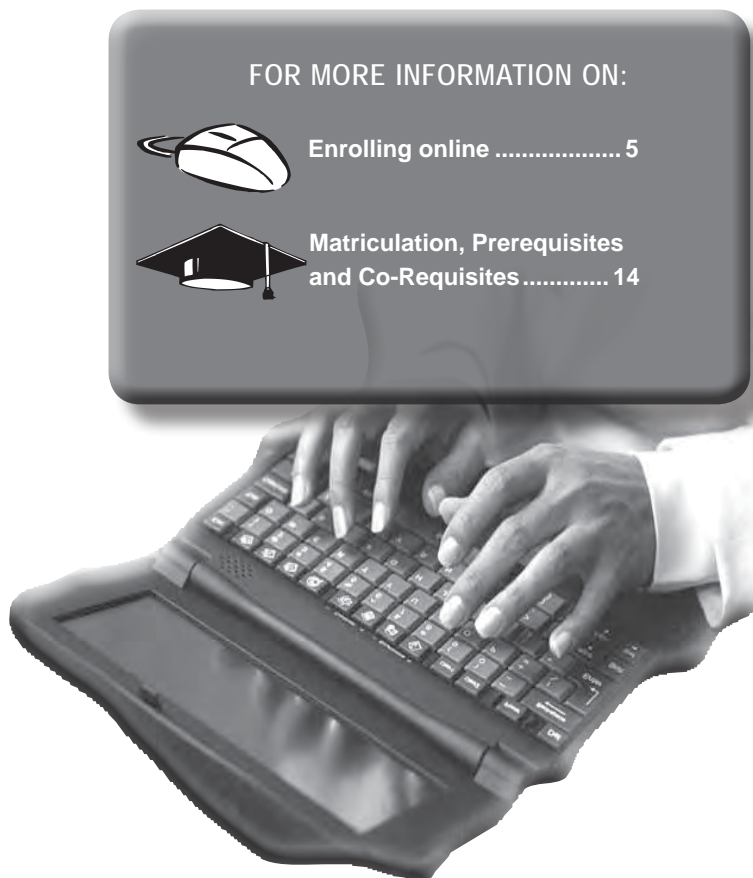

Enroll Online



1. From the LACC home page, click on **CURRENT STUDENTS** on the top menu bar.

Then, click the **“Student Information Link”** button.

OR, to link directly, type

http://www.lacc.edu/student_information/sis_logon.asp

The **Student Information System (SIS)** page will be displayed

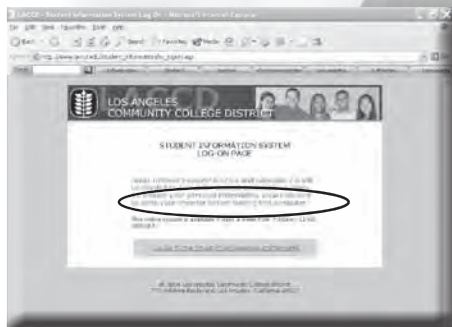

2. Click on **Student Information System** link.

3 The **SIS** menu will be displayed. Click on **Student Information System**.

4. The **SIS Sign-on** page will be displayed.

Sign-on to SIS:

- Enter your Student ID or Social Security number in the **SSN/SID** field
- Enter your 4-digit PIN (default PIN: month and day of birth)
- Click on **Submit** button.

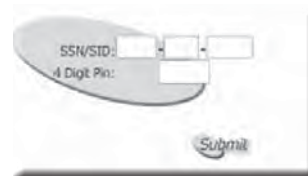

5. The **main menu** will be displayed.

Click on **Registration** option.

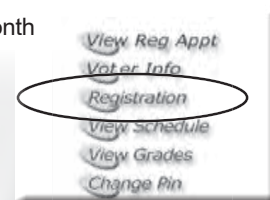

6. The **Registration** page will be displayed.

- Select the following:
- College
- Semester and Year
- Action (i.e., Add or Drop)
- Type in the Section Number.
- Click on **Submit** button

A message will be displayed indicating results of **Add or Drop** operation.

Be sure to write down your **confirmation number**.



FEES WORKSHEET

The fees listed were accurate at the time this schedule went to print but are **subject to change by the California Legislature**.

A: Enrollment fees	\$26.00 x _____ units =	\$ _____ . _____
B: Non-Resident Tuition for Out-of-State residents	\$188.00 x _____ units =	\$ _____ . _____
C: Non-Resident Tuition for International Students and/or F-1 VIS	\$198.00 x _____ units =	\$ _____ . _____
(Non-Resident International Students must also pay the enrollment fee of \$26 per unit)		
D: Health Center fee (mandatory)	\$11.00	\$ _____ . _____
E: Student Government (ASO) membership *	\$7.00	\$ _____ . _____
F: Restricted Parking Permit	\$20.00	\$ _____ . _____
G: Preferred Parking Permit with ASO membership	\$27.00	\$ _____ . _____
H: Student Political Representation Fee (mandatory)	\$1.00	\$ _____ . _____
I: TOTAL FEES DUE:		\$ _____ . _____

* You may waive this fee by filing a “Surrender of Benefits” form in person at the **Office of Student Life, LCR second floor**.

PAYMENT OPTIONS

In Person: Pay by cash, electronic check or credit card at the Business Office:

Monday-Thursday 8:00 a.m.-7:00 p.m.

Friday 9:00 a.m.-3:30 p.m.

By Mail: Pay by electronic check or money order.

LACC Business Office TR/ 855 North Vermont Ave./ Los Angeles, CA 90029

On-Line: Pay by Visa, Mastercard, American Express, Discover



How to Enroll

Esta información abreviada de inscripción en LACC, costo y ayuda económica es para ayudarle a usted a empezar el proceso. Para más información detallada, referirse a la sección en frente de nuestro horario o visite nuestro Student Assistant Center (AD105) o solicite Financial Aid (CH11A). Estas oficinas tienen dos personas que hablan varios idiomas.

¿QUIEN PUEDE SOLICITAR PARA INSCRIBIRSE?

- Una persona que terminó la preparatoria, o
- Una persona que tenga 18 años, y pueda beneficiarse de la instrucción, o
- Un estudiante de 18 años y que no terminó la preparatoria bajo unos programas especiales.

Usted no tiene que ser ciudadano estadounidense sin embargo, para calificar el costo de residente de California, los estudiantes deben tener un status que les permita establecerse en California de residente antes de la fecha de la residencia determinada. La fecha "Residencia determinada" es el día que sigue inmediatamente el primer día de instrucción del semestre que usted quiera asistir.

¿CÓMO PUEDE SOLICITAR?

1. Obtenga una solicitud para solicitar en el Internet o en el Student Assistant Center (AD 105)
2. La solicitud tiene que ser presentada en persona o a través del sistema de "RED" con una fotografía. También, traiga usted prueba de su número de seguro social. Si usted no tiene un número de seguro social, usted puede pedir a la escuela un número de indentificación.

PARA MATRICULARSE EN LAS CLASES

Estudiantes Nuevos: Después de someter su solicitud, usted recibirá una cita para inscribirse. usted puede inscribirse para las clases por teléfono o por el Internet a cualquier hora después de la fecha/hora de su cita.

Si es necesario, las computadoras y teléfonos están disponibles en la escuela para inscribir a los estudiantes.

Casi todos los estudiantes tendrán que hacer una cita para evaluación Administration Building 103. La evaluación ayuda a determinar el nivel apropiado de las clases que los estudiantes pueden tomar.

Nosotros recomendamos que los estudiantes nuevos participen en la orientación antes de matricularse en las clases.

Estudiantes Que Continúan: Si usted ha tomado clases en LACC en los últimos dos semestres, usted recibirá una cita

para matricularse por correo. usted puede matricularse para las clases por teléfono o por el internet a cualquier hora/

fecha después de su cita para matricularse. Las computadoras y teléfonos están disponibles para los estudiantes.

Estudiantes Que Vuelven: Si usted ha tomada clases en LACC pero, ha pasado dos semestres, usted es un estudiante que vuelve y debe seguir los pasos mencionados para los estudiantes nuevos.

Para matricularse por telefono, llamea uno de los siguientes numeros:
(323) 226-1999 (213) 689-8888
(310) 605-0505 (818) 988-2222

Para matricularse "Internet", vaya a:

<http://www.laccd.edu/stu-information/sis/login.asp>

o simplemente vaya a www.laccd.edu y siga la información.

COSTO DE MATRICULACION:

Residentes de Ca. Summer/Fall \$26.00 por unidad

No-residentes: \$186.00 por unidad (residentes fuera del estado; \$204 por unidad (estudiantes extranjeros)

No-residentes (estudiantes extranjeros) tienen que pagar \$26.00 de la matriculación por cada unidad.

Costos adicionales en la pagina 13.

AYUDA FINANCIERA:

Usted tiene que ser un ciudadano estadounidense o residente permanente para recibir ayuda económica. La ayuda económica incluye "grants" Ayuda Federal o Estatal y becas que usted tiene que pagar y préstamos de bajo interés. La ayuda le puede asistir a usted a pagar por la matriculación, libros y costo de vivienda.

PASO 1: Llene y someta la forma (FAFSA).

La forma está disponible en el Internet (www.fafsa.edu.gov) o en la oficina de Ayuda Financiera, Clausen Hall 111A.

PASO 2: Varias semanas más tarde, usted recibirá un Informe De Ayuda Estudiante (Student Aid Report) (SAR) en el correo. Tráigalo a la Oficina de Ayuda Financiera para empezar un fichero y hablar sobre cualquier problema con su solicitud.

PASO 3: La Oficina de Ayuda Financiera repasará su solicitud y automáticamente la matricula con excepcion financiera para los estudiantes que califican bajo este criterio.

PASO 4: La Oficina de Ayuda Financiera le mandará a usted una "Carta de notificación" que le explicará la ayuda que usted va a recibir.

PASO 5: Los cheques de FINANCIAL AID, serán enviados por correo o enviados electrónicamente a la cuenta de banco del estudiante durante el año. Típicamente su primer cheque llegará después de dos semanas después de que reciba la carta de notificación, pero puede tardar más tiempo.

LA MATRÍCULA CON EXCEPCIÓN FINANCIERA (FEE WAIVER)

Si usted es un residente de California con ingresos bajos, usted puede calificar para la matrícula con excepción financiera, la cual cubre la matrícula. Esta no cubre libros y mantenimiento (gastos). Para esto usted necesita llenar la solicitud de FAFSA para saber si usted puede calificar en estas áreas.

NOTA: Cuando usted someta la solicitud de FAFSA automáticamente es considerado para la matrícula con excepcion financiera. Si usted necesita la matrícula con excepcion financiera inmediatamente tendrá que llenar la solicitud respectiva. Estas formas están disponibles en la oficina de ayuda financiera, Clausen Hall 111A.

Դասերին գրանցվելու եւ նյութական օգնության վերաբերյալ ուղղություններ

Դասերին գրանցվելու եւ նյութական օգնության վերաբերյալ ուղղություններ

Այս համառոտ տեղեկությունը LACC (Լոս Անջելեսի քաղաքային քոլեջ) ընդունվելու, ուսումնավճարի եւ նյութական օգնության վերաբերյալ, կօգնի ձեզ սկսելու ձեր ուսումը: Ավելի մանրամասն տեղեկության համար օգտվեք այս դասացուցակի առաջին հատվածից, կամ այցելեցեք մեր ուսանողի օգնության կենտրոն՝ Student Assistant Center (AD 105), կամ նյութական օգնության կենտրոն՝ Financial Aid (CH111): Այս գրասենյակների աշխատակիցները խոսում են տարբեր լեզուներով:

Ո՛վ կարող է դիմել ընդունվելու համար

- Միջնակարգ դպրոցի շրջանավարտը, կամ
- 18 տարեկանից բարձր անձը, որը կարող է օգուտ ստանալ դասավանդումից, կամ
- Հատուկ ծրագրերի շրջանակներում՝ 18 տարեկանից ցածր ուսանողը, որը չի ավարտել միջնակարգ դպրոցը:

Պարտադիր չէ, որ դուք լինեք Ամերիկայի Միացյալ Նահանգների քաղաքացի՝ Սակայն, որպեսզի կարողանաք օգտվել Կալիֆոռնիայի բնակչի համար նախատեսված ուսման վճարի չափից, ուսանողները պետք է ունենան այնպիսի կարգավիճակ, որը նրանց հնարավորություն կտա դիտարկվելու որպես Կալիֆոռնիայի բնակիչ, նախքան նրանց բնակությունը կարգավիճակի որոշման ժամկետը: Բնակության որոշման օրն անմիջապես ձեր ուսումը սկսելու կիսամյակից մեկ օր առաջ է:

Ինչպե՛ս կարող եմ ես դիմել

1. Ձեռք բերեք ընդունելության դիմումի ձեւը՝ Application for Admission, համացանցից կամ ուսանողի օգնության կենտրոնից՝ Student Assistance Center (AD 105)
2. Դիմումնագրերը կարող են ներկայացվել անձամբ, կամ համացանցի միջոցով՝ նկարով անձը հաստատող փաստաթղթի հետ (photo ID): Բերեք, նաեւ, Ձեր սոցիալական ապահովության թվի՝ Social Security Number, ապացույցը: Եթե դուք չունեք SSN, ապա փոխարենը կարող եք պահանջել քոլեջի անհատական համար՝ ID Number:

Դասերին գրանցվելը

Նոր ուսանողները. Ձեր դիմումը ներկայացնելուց հետո Ձեզ գրանցման ժամադրություն կնշանակվի: Դուք կարող եք գրանցվել դասերին հեռախոսով կամ համացանցով, ցանկացած ժամանակ՝ Ձեր գրանցման ժամադրությունից հետո: Եթե կարիք լինի, քոլեջում կան համակարգիչներ եւ հեռախոսներ, որոնք կարող են ուսանողներն օգտագործել գրանցվելու համար: Ըստ ուսանողներ կարիք կունենան ժամադրություն

վերցնելու՝ գիտելիքների գնահատման համար (Assessment Window-AD1 103 Գնահատումը օգնում է որոշելու ուսանողներին համապատասխան մակարդակի դասեր վերցնելուն: Մենք նոր ուսանողներին վճռականորեն խորհուրդ ենք տալիս նախքան դասերին գրանցվելը մասնակցեն կողմնորոշման դասսին:

Ծարունակող ուսանողները. Եթե դուք վերջին երկու կիսամյակներում դասեր եք վերցրել LACC-ում, ապա գրանցման ժամադրությունը կստանաք նամակով: Դուք կարող եք գրանցվել դասերին հեռախոսով կամ համացանցով ցանկացած ժամանակ՝ Ձեր գրանցման ժամադրությունից հետո: Եթե կարիք լինի, քոլեջում կան համակարգիչներ եւ հեռախոսներ, որոնք կարող են ուսանողներին օգտագործել գրանցվելու համար:

Վերադարձող ուսանողները. Եթե, դուք LACC-ում դասեր եք վերցրել ավելի քան երկու կիսամյակ առաջ, ապա դուք վերադարձող ուսանողներ եք, եւ, պետք է հետեւեք նոր ուսանողների համար վերը նշված քայլերին:

Հեռախոսով՝ գրանցվելու համար, զանգահարեք հետեւյալ հեռախոսահամարներից որեւէ մեկով: Լրացուցիչ տեղեկություններ կարող եք գտնել 7-րդ էջում:

(323) 226-1999 (213) 689-8888 (310) 605-0505 (818) 988-2222

Համացանցով գրանցվելու համար այցելեք. http://www.laccd.edu/student_information/sis_logon.asp կամ ուղղակի www.laccd.edu եւ հետեւեք հղումներին:

Ուսման վճարը Կալիֆոռնիայի Ոչ բնակիչները	Աշուն-Զմեռ \$26 միավոր առարկայի համար (CA Residents)
	\$186.00 միավոր առարկայի համար՝ այլ նահանգների բնակիչների համար
	\$204.00 միավոր առարկայի համար՝ օտարերկրյա ուսանողների համար

Ոչ բնակիչ միջազգային ուսանողները պետք է վճարեն նաեւ ընդունելության համար \$26 միավոր առարկայի համար:
Կան նաեւ այլ վճարներ: Տեսեք Fees Schedule-ի էջը:
Բոլոր ուսանողական վճարները ենթակա են փոփոխության՝ առանց նախազգուշացնելու:



Matriculation is...

a process that assists students in meeting their educational goals. Participation in each matriculation step will assist you in identifying, planning, and achieving your educational and career goals. The purpose of Matriculation is to assist you in finding the campus resources, support services and college programs which are available to help you make better, more informed educational choices.

The College Agrees to Provide:

1. **ADMISSIONS** - A multilingual student staff in the Student Assistance Center will assist you in completing your admissions application and provide general campus information with confidential support and referrals (AD 105). Turn in your completed application to the Admissions Office (AD 100) then go to AD103 to schedule your Assessment appointment.
2. **ASSESSMENT** - You will take a basic skills assessment in reading, writing, language usage, and mathematics to help you select appropriate courses that are appropriate for you.
3. **ORIENTATION** - Introduces you to the campus resources, support services and college programs which are available to help you make better, more informed educational and career choices.
4. **COUNSELING** - Provides academic advisement and assistance in course selection, development of a Student Educational Plan, career planning, referral to appropriate student services, and Personal Development Classes which are taught by counseling faculty.
5. **FOLLOW-UP** - Provides regular evaluation of your progress through the Early Alert program and group counseling sessions.

The Student Agrees to:

1. Express at least a broad educational intent upon admission.
2. Declare a specific educational goal after completion of 15 semester units at the college.
3. Meet with a College Counselor to establish a Student Educational Plan and review the Educational Plan at least once each semester.
4. Maintain satisfactory progress toward an educational goal according to standards established by the Los Angeles Community College District and the State of California.

Exemption

As a student, you may be exempted from a step in the matriculation process if you meet at least one of the following criteria:

1. Have an AA, BA or higher degree from an accredited college or university.
2. Have completed English 28 or 101 and Mathematics 115 or equivalent courses.
3. Are enrolling for personal enrichment or recreational purposes without plans of taking more than 15 units of credit classes.

Even if you are not exempted from matriculation you may be exempted from assessment if you meet any of the following criteria:

1. Have a record of completing English 28 or 101 and Mathematics 115 or equivalent courses.
2. Have been assessed with the same or equivalent testing instruments at another school and have a record of these test results.

WAIVER: If you are not exempt from matriculation but choose not to participate in the process, a waiver is available in the Student Assistance Center, AD 105.

APPEAL: Matriculation is a campus-wide effort of faculty, administrators, staff and students. However, if for any reason, you feel that matriculation interferes with your rights as a student, forms for appeal are available in the Office of the Vice President of Student Services, AD 207.

Pre/Co-Requisites, Advisories & Challenges

NOTE: PREREQUISITES MAY BE ELECTRONICALLY ENFORCED

The following explains the conditions of enrollment that qualify a student for a class or course of study according to laws and state regulations AB 3 and Title 5.

PREREQUISITE is the requirement needed to qualify for a course. It is designed to identify skills necessary for success in a course.

CO-REQUISITE is the requirement for taking a simultaneous course in order to enroll in a particular class.

ADVISORY is advice given before enrolling. It is not required that a student follow this advice.

A **satisfactory grade** is an academic record with the symbol A, B, C, or "P."

Challenge Policy/Procedure

A student may challenge the above enrollment policies by filing a Prerequisite or Co-requisite Challenge Petition. You can obtain the form from the Admissions Office (AD 100), the Student Assistance Center (AD 105), of the Counseling Office (AD 108). Documented proof of your challenge will be required. The Petition must be filed with the Department Chair of the department over the class that is being challenged. If the College does not resolve your challenge within the five-day period, you will automatically be enrolled in the class. If no space is available in the class, the challenge shall be resolved before the beginning of registration for the next term. If your challenge is upheld and space is available, you may enroll in the next term.

Grounds for Challenges

It is your responsibility to show proof with documentation that you have grounds for a legitimate challenge. You may challenge any of the prerequisites or co-requisites using any of the Title 5 regulations listed below:

NOTE: If you have successfully completed a similar course outside of the Los Angeles Community College District, bring your official or unofficial transcripts or grade cards to the Counseling Office - AD 108 for evaluation.

1. The prerequisite/co-requisite does not follow the rules established by the District.
2. The prerequisite/co-requisite is in violation of Pre/Co-requisite and Advisory Regulation, specified in Section 55201(e) of Title V. (See Office of the Vice President of Student Services - AD207)
3. The prerequisite/co-requisite is unlawfully discriminatory or being applied in an unlawfully discriminatory manner. Once you have completed the Prerequisite or Co-requisite Challenge petition process on the grounds of unlawful discrimination, you have the right to file a formal complaint of unlawful discrimination with the Dean of Equity and Diversity (CH109).
4. You have the ability and knowledge to succeed in a course without the pre/co-requisite.
5. You will be subject to undue delay in obtaining your educational goal because the prerequisite/co-requisite course was not reasonably available.
6. You have not been allowed to enroll due to a limitation set for a course that involves intercollegiate competition, public performance, honor courses, or blocks of courses limited to a particular group of students. You will be allowed to enroll in such a course if there is no equivalent section offered, and you would be delayed a semester or more in obtaining your degree or certificate specified in your Student Educational Plan.
7. You want to enroll in a course which has prerequisite/co-requisite established to protect health and safety, and you can demonstrate that you do not pose a threat to yourself or others.

Resolution of Prerequisite Challenges

Each prerequisite challenge shall be investigated and resolved through the appropriate department chair no later than five (5) working days from the day that your challenge is filed.

Pre/Co-requisite Challenge Petition Filing Dates

Students may file challenges throughout the Fall and Summer semesters up to five (5) working days before the end of each semester. Some departments may accept petitions during summer session and winter intersessions, based on faculty availability.



How To Plan Your Schedule

A planning worksheet has been provided for you below. The state education code stipulates that each hour of a community college class shall require at least two hours of study outside of class. The maximum study load is 18 units during a regular semester, 12 units during a Summer Session and 7 units during a Winter Intersession. The normal class load for full-time students in the Winter or Fall semester is from 12 to 18 units per semester. Those students who will be employed while attending Los Angeles City College should reduce their programs accordingly. Students who are employed full-time should enroll in no more than 1 or 2 classes or a maximum of 9 units. The table to the right provides the suggested maximum class load for students who are also working.

SUGGESTED MAXIMUM CLASS LOAD

Your work _____ hours per week	40	30	20	10
Suggested Lecture Hours	3	6	9	12
Minimum Outside Study Time	6	12	18	24
Total Work/Schedule Related Hours	49	48	47	48

	MON	TUES	WED	THUR	FRI	SAT	
7:30 am							6:00 am
							7:00 am
9:05 am							8:00 am
							9:00 am
10:40 am							10:00 am
							11:00 am
12:15 pm							12:00 pm
							1:00 pm
3:30 pm							2:00 pm
							3:00 pm
6:50 pm							4:00 pm
							5:00 pm
							6:00 pm
							7:00 pm
							8:00 pm
							9:00 pm



Adds, Drops, etc.



Program Changes

You must present your validated Registration/Fee Receipt when making changes to your program. See the College Calendar (inside front cover) for important dates. It is your responsibility to assure that you follow all procedures for making changes to your program.

To Add a Class

You can add a class on the date/time of your registration appointment or anytime thereafter. Only students with an active application on file receive a registration appointment. Please go to page 9 to determine if you need to complete an admissions application.

Classes can be added through the Student Information System on the web until the first day of the semester or until classes are fill.. Once the semester begins, you may have to obtain an "Add Permit" from the instructor. In order to receive an "Add Permit", you must present one of the forms listed below to your instructor. It is your responsibility to submit the "Add Permit" to the Registration Center to officially register in the class.

- Registration/Fee Receipt
- Appointment to Register Postcard or Email
- Late Registration Card
- LACC Cub Card

"Add Permits" are processed in the Admission and Records Office located in AD 100.

Your instructor will not allow you to remain in the class unless you are officially registered in the class.

To Drop / Withdraw From Classes

Use the Student Information System on the web to drop a class or classes you no longer plan to attend. Since it is the students' responsibility to drop a class, **write down the confirmation number for your records.**

Drops can also be processed in the Admissions and Records Office. Please check the college calendar inside the front cover of this schedule for important dates.

PLEASE NOTE: *It is the students' responsibility to drop a class no longer being attempted. Failure to drop a class in a timely manner may result in a "W" or an "F" on your academic record. You may also be held accountable for payment of all fees whether you attend or do not attend class.*

EDUCATIONAL FOR SUSTAINABLE LEADERSHIP



FALL 2010

How to Join a Student Sustainability Workshop

- 1) Sign up in class or e-mail stulife@lacitycollege.edu to reserve your spot space is limited, so sign up today!
- 2) Meeting times to be announced.
 - 7 Classes .Each meeting lasts for 1 hour and 30 minutes
 - Meetings take place at the LACC campus, Room TBD

Workshop Requirements

- 1) Attend and participate in all meetings (see schedule below)
 - One absence permitted (with make-up assignment)
 - Complete and turn in Sustainability Survey and weekly homework assignments
- 2) Complete 3 hours of community service
 - Community service opportunities provided by Sustainable Works

Meeting Topics and Schedule

Workshop Meetings take place on the LACC campus, in Room TBD

Mtg. 1 Orientation
Mtg. 2 Water
Mtg. 3 Energy
Mtg. 4 Solid Waste

Mtg. 5 Chemicals
Mtg. 6 Transportation
Mtg. 7 Shopping and Food

Sponsored By Associated Student Organization

BASIC SKILLS ENROLLMENT LIMITATION

TITLE 5, CALIFORNIA CODE OF REGULATIONS, LIMITS STUDENT FROM TAKING MORE THAT 30 UNITS OF "REMEDIAL" COURSE WORK, WHICH IS DEFINED AS "NONDEGREE-APPLICABLE BASIC SKILLS COURSES." EFFECTIVE WINTER 2010, THE COLLEGE'S REGISTRATION SYSTEM WILL PREVENT STUDENTS, WHO HAVE EXCEEDED THIS LIMIT, FROM ENROLLING IN ADDITIONAL BASIC SKILLS COURSES. HOWEVER A STUDENT, WHO HAS REACHED THIS LIMIT BUT ENROLLS IN A CREDIT OR NONCREDIT ENGLISH AS A SECOND LANGUAGE (ESL) COURSE, WILL BE ALLOWED TO ENROLL IN ADDITIONAL BASIC SKILLS COURSES. STUDENTS WITH A LEARNING DISABILITY MAY REQUEST AN EXEMPTION THROUGH THE DISABLED STUDENT PROGRAMS AND SERVICES (DSPS) OFFICE. ALSO, THIS LIMITATION DOES NOT APPLY TO ENROLLMENT IN NONCREDIT BASIC SKILLS COURSES.





Financial Aid Information

You may apply for financial aid to assist with: Enrollment Fees • Books • Living Expenses (Rent, etc.)

PLAN AHEAD & COMPLETE THE FAFSA

It takes a little time to complete the Free Application for Federal Student Aid (FAFSA). Once your form has been submitted, it will take several weeks to process. And, it will take several additional weeks before your first financial aid check arrives.

- Financial aid is available to students who can demonstrate financial need.
- Non-California residents may also qualify for financial aid.
- Non-residents who don't qualify for a fee waiver, may be eligible for financial aid.

PAY ATTENTION TO DEADLINES

Fall SEMESTER: To increase the likelihood that your financial aid check will arrive at the beginning of the FALL semester, submit your application in the Fall (usually by March 2).

FALL SEMESTER: To increase the likelihood that your financial aid check will arrive at the beginning of the Fall semester, submit your application at least three months prior to the start of the semester (usually mid-November). (You may apply for aid through the end of each semester. However, the later you apply, the later you will receive your financial aid funds.)

ENROLLMENT FEE WAIVERS

If you are a low-income resident of California, you may qualify for a Board of Governors Enrollment Fee Waiver which covers your enrollment fee. It DOES NOT cover books and living expenses. It is recommended that you complete the FAFSA to apply for a fee waiver.

NOTE: When you submit the FAFSA form, you are automatically considered for the fee waiver. If you need the fee waiver immediately, however, you may use a separate Board of Governors Fee Waiver form. Forms are available in the Financial Aid Office, Clausen Hall 111A. Usted puede solicitar ayuda financiera para lo siguiente: Matrícula • Libros • Gastos (Alquiler de Casa, etc.)

PLANEE A TIEMPO & COMPLETE LA SOLICITUD DE FAFSA

Toma poco tiempo en completar la aplicación FAFSA. Si necesita ayuda para esto puede ir a FASTLAB en la MLK Library por asistencia. Después de haber completado la forma, el proceso tomará varias semanas y también tomará unas cuantas semanas para que usted reciba el primer cheque.

- La ayuda financiera está disponible para los estudiantes que pueden demostrar que la necesitan.
- Las personas que no son residentes de California tal vez puedan calificar para la ayuda financiera.
- Si usted no califica para una matrícula con excepción financiera (fee waiver), por no ser Residente de California, usted podría ser elegible para ayuda financiera.

POR FAVOR PONGA ATENCIÓN A LAS FECHAS LÍMITES

EN EL SEMESTRE DEL OTOÑO: Para asegurarse que el cheque de ayuda financiera llegue al principio del semestre del otoño, someta la solicitud en el semestre de la primavera (usualmente el 2 de marzo).

EN EL SEMESTRE DE LA PRIMAVERA: Para asegurarse que el cheque de ayuda financiera llegue al principio del semestre de la primavera someta la solicitud por lo menos tres meses antes del comienzo del semestre (usualmente a mediados de noviembre). (Puede solicitar ayuda hasta el final de cada semestre. Sin embargo, si usted solicita tarde, usted recibirá su ayuda tarde.)

LA MATRÍCULA CON EXCEPCIÓN FINANCIERA (FEE WAIVER)

Si usted es un residente de California con ingresos bajos, usted puede calificar para la matrícula con excepción financiera, la cual cubre la matrícula. Esta no cubre libros y mantenimiento (gastos).

Para esto usted necesita llenar la solicitud de FAFSA para saber si usted puede calificar en estas áreas. Comenzando el otoño 2006, el honorario de la salud no será cubierto por la matrícula con excepción financiera (fee waiver). Será la responsabilidad del estudiante pagarlo.

NOTA: Cuando usted someta la solicitud de FAFSA automáticamente es considerado para la matrícula con excepción financiera. Si usted necesita la matrícula con excepción financiera inmediatamente tendrá que llenar la solicitud respectiva. Estas formas están disponibles en la oficina de ayuda financiera, Clausen Hall 111A

5 STEPS TO REMEMBER

STEP 1

Complete and submit the FAFSA form.

Form available on-line (www.fafsa.ed.gov) or in the Financial Aid Office, Clausen Hall 111A.

STEP 2

Several weeks later, you will receive a Student Aid Report (SAR) acknowledgment in the mail. Bring it to the Financial Aid Office to open a financial aid file and discuss any problems with your application.

STEP 3

The Financial Aid Office will review your application and automatically processes a fee waiver for students who meet the criteria.

STEP 4

The Financial Aid Office will then send you an Award Notification Letter which states how much aid you will receive.

STEP 5

Financial aid checks are either sent by mail or transferred electronically to the student's bank account during the school year.

Typically your first award check will arrive two weeks after you receive the Award Notification, BUT IT CAN TAKE LONGER.



Fees Schedule: Fall 2010



These fees were accurate at the time this schedule went to print but may be subject to change
FEES MAY BE PAID AT THE BUSINESS OFFICE BY CASH, CHECK, VISA, MASTERCARD OR AMERICAN EXPRESS OR ONLINE VIA CREDIT CARD. \$10 MINIMUM REQUIRED ON ALL CHECK AND CREDIT CARD TRANSACTIONS. \$10 RETURN CHECK FEE.

ENROLLMENT FEE (CA RESIDENTS) Fall \$26 PER UNIT (NO MAX PER SEMESTER)

Note: that all student fees are subject to change without notice. If at the time you enroll you are receiving benefits under the Temporary Assistance to Needy Families (TANF) or the General Assistance Program, the enrollment fee will be waived. For information on requesting a waiver, contact the College Financial Aid Office before you enroll for classes. Financial aid may be available to students who meet the qualification requirements. If you have questions about your eligibility to receive financial aid, please contact the Financial Aid Office. Because there are specific deadlines for financial aid opportunities, you must submit your documents within the timeline established by the program issuing funds.

ENROLLMENT FEE ASSISTANCE

Los Angeles City College offers enrollment fee assistance to eligible students who are unable to pay the enrollment fee. An Automatic Fee Waiver will be processed for eligible California residents who have a Free Application for Federal Student (FAFSA) on file with the College Financial Aid Office. All other students must contact the Financial Aid Office to obtain a Board of Governors Fee Waiver (BOGFW) Application. The enrollment fee waiver is available to students whose families receive TANF, General Assistance or Social Security Benefits. The BOGFW is also available to students whose family income and size Winter within established income levels. Additionally, dependents of veterans of the United States military or the California National Guard, recipients of the Congressional Medal of Honor, and children of or dependents of a victim of the September 11 terrorist attack may qualify for the BOGFW. In addition, a dependent of a deceased law enforcement or fire suppression personnel killed in the line of duty may qualify.

CRITERIA FOR BOARD OF GOVERNORS ENROLLMENT FEE WAIVER 2010-2011

NUMBER IN HOUSEHOLD INCLUDING YOURSELF

1	2	3	4	5	6	7	8	Plus
\$16,245	\$21,855	\$27,465	\$33,075	\$37,085	\$44,295	\$49,905	\$55,51	Add an adl \$5,610 for each dependent

MAXIMUM TOTAL FAMILY INCOME IN 2006 (adjusted gross and/or untaxed income)

ENROLLMENT FEE REFUNDS

For full-session classes, a full refund of the enrollment fee will be made through the end of the second week of classes. For short-term classes, a full refund is available up to the end of a period equal to ten percent (10%) of the total session length. No refund will be authorized after the periods described above except when college action to cancel or reschedule a class necessitates the drop. Students must request refunds in the Business Office. Credit card refunds will be processed a week after filing the request.

NOTE: After the second week, fees for dropped classes will be applied to fees for classes added simultaneously or after a drop. No refunds will be given for drop transactions alone. Students are strongly advised to complete add and drop transactions simultaneously, within the authorized dates for doing so.

FINANCIAL AID REPAYMENT REGULATIONS

Students who receive federal financial aid and totally withdraw from ALL classes will have to repay some of the federal funds received prior to withdrawal. All students who receive federal funds and withdraw from the college in the first 60% of the term, are subject to Federal Repayment Regulations. The Financial Aid Office will calculate the amount of federal funds earned up to the point of withdrawal and students will be billed and must repay any federal grant funds received but not earned. Failure to repay these funds will result in the denial of future federal financial aid. It is advised that you contact the Financial Aid Office before withdrawing from all of your classes so you understand the results of your actions. For the refund policy on enrollment fees and nonresident tuition, please see the College Schedule of Classes or the College Catalog.

NON-RESIDENT TUITION FEE \$186 PER UNIT OUT OF STATE RESIDENTS \$204 PER UNIT FOREIGN CITIZENS

Non-Resident International Students must also pay the enrollment fee of \$26 per unit

ASSOCIATED STUDENT ORGANIZATION FEE \$7 PER SEMESTER

The \$7 per semester fee provides students with ASO benefits & services. In addition to preferred parking, you can receive free bluebooks, scantrons, copy and fax, use computers, access the internet, win a book grant, etc. at the ASO Services Center. Students may waive this fee, but every student must comply with the ASO fee in one of two ways: 1) pay the fee, or, 2) submit a Surrender of Benefits form. If you decline all ASO benefits and choose not to pay the fee, you may pick up a Surrender of Benefits form at the Office of Student Life, Learning Resource Center 2nd floor. The completed form must be returned to the Business Office. NOTE: During the Summer and Winter Sessions, the fee is \$3.00. Fees may not be refunded after the second week of classes

STUDENT REPRESENTATION FEE \$1 PER SEMESTER

This required, non-refundable, fee benefits LACC students by enabling your ASO to respond to legislative issues which impact students directly, i.e. tuition increases, textbook taxes, community college funding. The ASO advocates and lobbies on your behalf and is your legally designated liaison with the college, the District, the State Chancellor's Office, and other state and federal governmental organizations. You may waive your right to be represented by completing a form available in the Office of Student Life, Learning Resource Center 2nd floor or the Business Office, AD 111. The completed Student Rep Fee Waiver must be filed at the Business Office.

HEALTH SERVICES FEE \$11 PER SEMESTER

The Los Angeles Community College District charges an eleven dollar (\$11) mandatory, non-refundable Health Fee. The fee is payable to one campus only and covers the costs of Health Centers at the District's nine campuses. (For waiver information, see "Policies-General.") NOTE: During the Winter and Summer sessions, the fee is \$8.00.

INSTRUCTIONAL MATERIALS FEE

Students may be required to provide instructional and other materials mandated for a credit/no-credit course. Such materials shall be of continuing value to a student outside the classroom setting and shall not be solely or exclusively available from the Los Angeles Community College District. If you qualify for a fee waiver, you may obtain one at the Student Assistance Center (AD105) or Clausen Hall (CH109).

PARKING FEE \$20 PER SEMESTER

Parking in Student Parking Lot #1 & #2 & #3 will be restricted to vehicles displaying a valid permit. A permit is required at all times. There is no free replacement for lost or stolen permits. Permit procedures, fees, and refund information are available under "Parking Policies" in this schedule and in the Business Office.

Fall Permits: \$10

Fall or Spring: **Preferred Parking \$27** (Lot #1 and Lot #2 (ground floor & structure of Vermont lot) and Lot #3 (on Heliotrope) AND includes membership in the Associated Student Organization. Restricted Parking \$20 - Lot #2 ONLY [structure section of Vermont lot] A limited number of restricted permits are available each semester

Summer Permits: \$10



On Line Classes Fall 2010



NOTE: STUDENTS WHO ENROLL IN ON LINE CLASSES MUST HAVE AN ACTIVE E-MAIL ACCOUNT. IN ADDITION, YOU MUST:

1. Contact your instructor before the first day of class at the e-mail address listed in the main class listing section.
2. If no e-mail address is listed, call the appropriate Department for further instructions.

ON LINE CLASSES FALL 2010

SECTION	COURSE		INSTRUCTOR
0108	ACCOUNTING	21	BG Tiwari
0105	ACCOUNTING	21	BG Tiwari
0106	ACCOUNTING	27	BG Tiwari
0115	ACCOUNTING	41	BG Tiwari
0111	ACCOUNTING	42	BG Tiwari
0213	ANTHROPOLOGY	102	BG Tiwari
0264	CHICANO STUDIES	007	CR Guerrero
3101	CHICANO STUDIES	044	CR Guerrero
0270	CHILD DEV.	001	KM Miller
1013	CAOT	001	CS Morimoto
1039	CAOT	084	CS Morimoto
1050	CAOT	085	TJ Day
0248	CSIT	101	LA Flores
0329	CSIT	101	S Dakduk
3140	CSIT	101	M Pashazadeh
0256	CSIT	103	M Tavakoli
0317	CSIT	103	M Pashazadeh
3146	CSIT	103	S Dakduk
0257	CSIT	104	BP Dautat
0258	CSIT	107	PS Atkinson
3649	CSIT	158	CC Holliday
3182	ECONOMICS	001	JE Holzner
0380	ECONOMICS	002	JE Holzne
0418	ENGLISH	028	RE Lapp
1338	ENGLISH	028	TR Robinson
0497	ENGLISH	067	N Robinson

0479	ENGLISH	101	TR Robinson
3226	ENGLISH	101	ED O'Connell
3703	ENGLISH	101	F Tamayo
0555	ENGLISH	102	F Tamayo
0556	ENGLISH	103	GG Patthey
1355	ENGLISH	103	EW Kenall
0263	ENGLISH	211	GG Patthey
3239	ENGLISH	270	MS Boretz
0564	FAMILY CONSUMER	021	GB Stafsky
3027	HEALTH	011	NJ Cairns
3028	HEALTH	011	NJ Cairns
3308	INTL BUS	001	RB Hastey
0591	INTL BUS	004	TJ Day
0592	INTL BUS	005	TJ Day
3309	INTL BUS	006	RB Hastey
0144	LAW	001	KC Lanzer
1610	LAW	001	RP Lewis
0891	MATH	227	MR Araeipour
1127	POLI SCI	001	JN Meyer
1132	POLI SCI	001	M Aaron
3022	POLI SCI	001	M Aaron
3518	POLI SCI	001	JN Meyer
1180	PSYCHOLOGY	027	AB Baldwin
3007	REAL ESTATE	001	RL Anderson
1202	REAL ESTATE	060	RL Anderson
1222	SOCIOLOGY	001	A Clark
3615	SUPERVISION	001	RB Hastey

www.lacitycollege.edu

Credit Short Term Classes

SECTION#	TIME	DAYS	INSTRUCTOR	LOCATION
ART 101				
9550	- 2:20 hrs	TBA	STAFF	BRAI LLE
<i>(21 Week Class Starts 8/30/2010, Ends 1/30/2011)</i>				
ADVISORY: CSIT 103				
1627	LEC 9:00 am - 10:25 am	MTWTh	DAUZAT, B P	FH 202
<i>(8 Week Class Starts 8/30/2010, Ends 10/21/2010)</i>				
COMPUTER SCIENCE INFORMATION TECHNOLOGY 107				
0334	LEC 9:00 am - 10:25 am	MTWTh	DAUZAT, B P	FH 202
<i>(8 Week Class Starts 10/25/2010, Ends 12/19/2010)</i>				
COMPUTER SCIENCE INFORMATION TECHNOLOGY 139				
1625	LEC 10:35 am - 12:45 pm	M W	DAUZAT, B P	FH 202
AND	4:20 hrs	TBA	DAUZAT, B P	ON LINE
<i>(8 Week Class Starts 8/30/2010, Ends 10/21/2010)</i>				
COMPUTER SCIENCE INFORMATION TECHNOLOGY 140				
0335	LEC 10:35 am - 12:45 pm	M W	DAUZAT, B P	FH 202
AND	LAB 4:20 hrs	TBA	DAUZAT, B P	ON LINE
<i>(8 Week Class Starts 10/25/2010, Ends 12/19/2010)</i>				
DANCE TECHNIQUES 437				
2150	LAB 10:35 am - 12:40 pm	M W	ECKLER, P	WG 202
<i>(8 Week Class Starts 8/30/2010, Ends 10/20/2010)</i>				
2151	LAB 10:35 am - 12:40 pm	M W	ECKLER, P	WG 202
<i>(8 Week Class Starts 10/25/2010, Ends 12/19/2010)</i>				
DANCE TECHNIQUES 468				
2006	LAB 10:35 am - 12:40 pm	M W	ECKLER, P	WG 206
<i>(8 Week Class Starts 10/25/2010, Ends 12/19/2010)</i>				
ENGLISH 028				
0418	6:00 hrs	TBA	LAPP, R E	ON LINE
<i>(8 Week Class Starts 8/30/2010, Ends 10/24/2010)</i>				
0431	LEC 9:00 am - 12:10 pm	T Th	MAECK, A T	HH 205
<i>(8 Week Class Starts 8/30/2010, Ends 10/23/2010)</i>				
ENGLISH 101				
0454	LEC 9:00 am - 12:00 pm	T Th	MAECK, A T	HH 205
<i>(8 Week Class Starts 10/25/2010, Ends 12/19/2010)</i>				
0588	6:30 hrs	TBA	LAPP, R E	ON LINE
<i>(8 Week Class Starts 10/25/2010, Ends 12/19/2010)</i>				
1619	LEC 9:00 am - 12:20 pm	M W	PEARLMAN, A S	CHEM 201
<i>(8 Week Class Starts 8/30/2010, Ends 10/24/2010)</i>				
3221	LEC 6:50 pm - 10:00 pm	T Th	MAECK, A T	JH 101
<i>(8 Week Class Starts 8/30/2010, Ends 10/23/2010)</i>				
3699	LEC 6:50 pm - 10:10 pm	M W	NISHIMURA, J M	HH 107
<i>(8 Week Class Starts 10/25/2010, Ends 12/19/2010)</i>				
ENGLISH 102				
0469	LEC 9:00 am - 12:00 pm	M W	MARDIRUSSIAN, G	JH 203
<i>(8 Week Class Starts 10/25/2010, Ends 12/19/2010)</i>				
ENGLISH 103				
0477	LEC 9:00 am - 12:20 pm	M W	PEARLMAN, A S	CHEM 201
<i>(8 Week Class Starts 10/25/2010, Ends 12/19/2010)</i>				
3232	LEC 6:50 pm - 10:00 pm	T Th	MAECK, A T	JH 101
<i>(8 Week Class Starts 10/25/2010, Ends 12/19/2010)</i>				
HEALTH 011				
3027	LEC 6:30 hrs	TBA	CAIRNS, N J	ON LINE
<i>(8 Week Class Starts 8/30/2010, Ends 10/22/2010)</i>				
3028	LEC 6:30 hrs	TBA	CAIRNS, N J	ON LINE
<i>(8 Week Class Starts 10/25/2010, Ends 12/19/2010)</i>				
LEARNING SKILLS 003C				
8205	LAB 3:10 hrs	TBA	DES VIGNES, M	PLAT LAB
<i>(16 Week Class Starts 8/30/2010, Ends 12/19/2010)</i>				
LEARNING SKILLS 015A				
8259	LEC 12:45 pm - 3:35 pm	M	ALLEN, J F	LRC 104C
<i>(6 Week Class Starts 9/13/2010, Ends 10/22/2010)</i>				
LEARNING SKILLS 015B				
8262	LEC 12:45 pm - 3:35 pm	M	ALLEN, J F	LRC 104C
<i>(6 Week Class Starts 10/25/2010, Ends 12/10/2010)</i>				

SECTION#	TIME	DAYS	INSTRUCTOR	LOCATION
MATHEMATICS 215				
0886	LEC 8:50 am - 12:00 pm	S	KARAPETYAN, A	FH 108
AND	LEC 12:50 pm - 4:00 pm	S	KARAPETYAN, A	FH 108
<i>(7 Week Class Starts 8/30/2010, Ends 10/16/2010)</i>				
MATHEMATICS 216				
0887	LEC 8:50 am - 12:00 pm	S	KARAPETYAN, A	FH 108
AND	LEC 12:50 pm - 4:00 pm	S	KARAPETYAN, A	FH 108
<i>(7 Week Class Starts 10/23/2010, Ends 12/19/2010)</i>				
PHYSICAL EDUCATION 225				
2184	LAB 10:45 am - 12:50 pm	M W	GLICKMAN, D C	WG 202
<i>(8 Week Class Starts 8/30/2010, Ends 10/20/2010)</i>				
2185	LAB 10:45 am - 12:50 pm	M W	GLICKMAN, D C	WG 206
<i>(8 Week Class Starts 10/25/2010, Ends 12/19/2010)</i>				
PHYSICAL EDUCATION 630				
2859	LAB 1:30 pm - 3:40 pm	M W	TINBERG, C	WG 109
<i>(8 Week Class Starts 10/25/2010, Ends 12/19/2010)</i>				
PSYCHOLOGY 001				
1147	LEC 9:00 am - 12:10 pm	F	BALDWIN, A B	HH 101
AND	LEC 1:00 pm - 4:05 pm	F	BALDWIN, A B	HH 101
<i>(8 Week Class Starts 10/15/2010, Ends 12/10/2010)</i>				
PSYCHOLOGY 027				
1180	19:05 hrs	TBA	BALDWIN, A B	ON LINE
<i>(4 Week Class Starts 10/23/2010, Ends 11/13/2010)</i>				
3479	LEC 1:45 pm - 3:45 pm	h	BLUM, J S	HH 101
<i>(10 Week Class Starts 10/6/2010, Ends 12/19/2010)</i>				
REGISTERED, NURSING 104				
6101	LEC 9:30 am - 12:00 pm	M	STAFF	SCI 107
AND	LEC 9:30 am - 12:00 pm	Th	UPSHAW, D K	SCI 107
OR	LAB 7:00 am - 1:30 pm	TW	AUSTIN, N	FIEL D
OR	LAB 7:00 am - 1:30 pm	TW	STAFF	FIEL D
OR	LAB 7:00 am - 1:30 pm	TW	UPSHAW, D K	FIEL D
<i>(8 Week Class Starts 8/30/2010, Ends 10/22/2010)</i>				
REGISTERED, NURSING 105				
6105	LEC 9:30 am - 12:40 pm	M	STAFF	SCI 107
AND	LEC 9:00 am - 12:10 pm	Th	UPSHAW, D K	SCI 107
OR	LAB 7:00 am - 3:30 pm	TW	AUSTIN, N	FIEL D
OR	LAB 7:00 am - 3:30 pm	TW	UPSHAW, D K	FIEL D
OR	LAB 7:00 am - 3:30 pm	TW	STAFF	FIEL D
<i>(8 Week Class Starts 10/25/2010, Ends 12/19/2010)</i>				
REGISTERED, NURSING 110				
0999	LEC 9:00 am - 1:40 pm	M	FARRAND, F M	CD 214
AND	LAB 7:00 am - 3:00 pm	T W	FARRAND, F M	FIEL D
OR	LAB 7:00 am - 3:00 pm	T W	FEKETE, M M	FIEL D
OR	LAB 7:00 am - 3:00 pm	Th F	PABELLANO, M A	FIEL D
<i>(8 Week Class Starts 8/30/2010, Ends 10/24/2010)</i>				
REGISTERED, NURSING 111				
1000	LEC 9:00 am - 1:15 pm	M	FARRAND, F M	CD 214
AND	LAB 7:00 am - 2:30 pm	T W	FARRAND, F M	FIEL D
OR	LAB 7:00 am - 2:30 pm	T W	FEKETE, M M	FIEL D
OR	LAB 7:00 am - 2:30 pm	Th F	STAFF	FIEL D
<i>(7 Week Class Starts 10/25/2010, Ends 12/19/2010)</i>				
REGISTERED, NURSING 150				
6120	LEC 8:00 am - 3:00 pm	T Th	SIMPSON TURK, J Y	OFF CAMP
AND	LAB 8:00 am - 3:00 pm	M W F	STAFF	OFF CAMP
<i>(8 Week Class Starts 8/30/2010, Ends 10/22/2010)</i>				
6130	LEC 8:00 am - 3:00 pm	T Th	SIMPSON TURK, J Y	OFF CAMP
AND	LAB 8:00 am - 3:00 pm	M W F	STAFF	OFF CAMP
<i>(8 Week Class Starts 8/30/2010, Ends 10/22/2010)</i>				
6140	LEC 8:00 am - 2:30 pm	T Th	SIMPSON TURK, J Y	OFF CAMP
AND	LAB 8:00 am - 3:00 pm	M W F	SIMPSON TURK, J Y	OFF CAMP
<i>(8 Week Class Starts 8/30/2010, Ends 10/22/2010)</i>				
6160	LAB 8:00 am - 3:05 pm	T Th	SIMPSON TURK, J Y	OFF CAMP
AND	LAB 8:00 am - 3:00 pm	M W F	SIMPSON TURK, J Y	OFF CAMP
<i>(8 Week Class Starts 8/30/2010, Ends 10/22/2010)</i>				
REGISTERED, NURSING 151				
6121	LEC 8:00 am - 2:30 pm	T	SIMPSON TURK, J Y	OFF CAMP
AND	LAB 7:00 am - 4:05 pm	WThF	SIMPSON TURK, J Y	OFF CAMP
<i>(8 Week Class Starts 10/25/2010, Ends 12/19/2010)</i>				

SECTION#	TIME	DAYS	INSTRUCTOR	LOCATION
6131	LAB 8:00 am - 3:00 pm	T	SIMPSON TURK, J Y	OFF CAMP
AND	LAB 7:00 am - 4:05 pm	M WThF	SIMPSON TURK, J Y	OFF CAMP
<i>(8 Week Class Starts 10/25/2010, Ends 12/19/2010)</i>				
6141	LEC 8:00 am - 2:30 pm	T	SIMPSON TURK, J Y	OFF CAMP
AND	LAB 7:00 am - 6:25 pm	M WTh	SIMPSON TURK, J Y	OFF CAMP
<i>(8 Week Class Starts 10/25/2010, Ends 12/19/2010)</i>				
6161	LEC 8:00 am - -3:00 pm	T	SIMPSON TURK, J Y	OFF CAMP
AND	LAB 7:00 am - 4:05 pm	M WThF	SIMPSON TURK, J Y	OFF CAMP
<i>(8 Week Class Starts 10/25/2010, Ends 12/19/2010)</i>				

SUPERVISION 001

3616	LEC 6:50 pm - 10:00 pm	T Th	EGEREGOR, A E	DH 303
<i>(8 Week Class Starts 10/25/2010, Ends 12/19/2010)</i>				

NON CREDIT SHORT TERM CLASSES

BASIC SKILLS 006 CE

5722	1:00 pm - 3:10 pm	M W	CORDOVA, L A	TBA TB
<i>(8 Week Class Starts 9/6/2010, Ends 10/30/2010)</i>				
5756	2:00 pm - 4:00 pm	MTW	STAFF	TBA TBA
<i>(6 Week Class Starts 10/18/2010, Ends 11/26/2010)</i>				
5825	4:15 hrs	TBA	CORSO, M E	TBA TBA
<i>(8 Week Class Starts 10/25/2010, Ends 12/13/2010)</i>				
5829	8:30 am - 9:35 am	T Th	WATIER, E R	TBA TBA
<i>(15 Week Class Starts 8/30/2010, Ends 12/11/2010)</i>				
5948	2:00 pm - 4:00 pm	MTW	STAFF	TBA TBA
<i>(6 Week Class Starts 9/6/2010, Ends 10/13/2010)</i>				
8705	9:00 am - 12:50 pm	T Th	STAFF	CCW 26
<i>(5 Week Class Starts 8/31/2010, Ends 9/28/2010)</i>				
8711	9:00 am - 12:05 pm	T Th	CORDOVA, L A	CCW 260
<i>(6 Week Class Starts 11/2/2010, Ends 12/11/2010)</i>				
8734	10:00 am - 12:20 pm	F	STAFF	TBA TBA
<i>(14 Week Class Starts 8/30/2010, Ends 12/11/2010)</i>				
8740	5:05 hrs	TBA	STAFF	AD 301B
<i>(7 Week Class Starts 11/1/2010, Ends 12/19/2010)</i>				
8845	3:03 hrs	TBA	CORSO, M E	OFF CAMP
<i>(11 Week Class Starts 10/6/2010, Ends 12/19/2010)</i>				
8926	9:00 am - 12:50 pm	T Th	STAFF	CCW 260
<i>(5 Week Class Starts 9/30/2010, Ends 10/30/2010)</i>				

BASIC SKILLS 007CE REVIEW OF BASIC MATH (NDA) 0.00 UNITS

5949	12:30 pm - 3:20 pm	T Th	EK, K	TBA TBA
<i>(7 Week Class Starts 11/1/2010, Ends 12/17/2010)</i>				
8716	8:00 am - 11:20 am	T Th	ARRIOLA, P	JOB CORP
<i>(6 Week Class Starts 11/1/2010, Ends 12/11/2010)</i>				
8723	12:00 pm - 2:20 pm	W	RODRIGUEZ, J ISEIU INTE	
<i>(14 Week Class Starts 9/6/2010, Ends 12/8/2010)</i>				
876	8:00 am - 11:05 am	T Th	TUFFA, A A	JOB CORP
<i>(6 Week Class Starts 11/8/2010, Ends 12/19/2010)</i>				
8849	1:00 pm - 3:20 pm	T Th	EK, K	TBA TBA
<i>(8 Week Class Starts 9/10/2010, Ends 10/30/2010)</i>				
8927	8:00 am - 11:50 am	T Th	ARRIOLA, P	JOB CORP
<i>(5 Week Class Starts 9/29/2010, Ends 10/30/2010)</i>				
8931	8:00 am - 12:15 pm	T Th	ARRIOLA, P	JOB CORP
<i>(5 Week Class Starts 8/30/2010, Ends 9/27/2010)</i>				
8932	8:00 am - 10:20 am	M W F	TUFFA, A A	JOB CORP
<i>(5 Week Class Starts 8/30/2010, Ends 10/1/2010)</i>				
8933	8:00 am - 10:10 am	M W F	TUFFA, A A	JOB CORP
<i>(5 Week Class Starts 10/4/2010, Ends 11/5/2010)</i>				

CAREER DEVELOPMENT SKILLS 238CE

5717	1:00 pm - 2:15 pm	T Th	CASTELLON, H G	TBATBA
<i>(13 Week Class Starts 9/20/2010, Ends 12/19/2010)</i>				
8721	5:00 pm - 8:50 pm	M	CORSO, M E	CCW 259
<i>(9 Week Class Starts 9/20/2010, Ends 11/22/2010)</i>				
8730	LEC 1:00 pm - 2:15 pm	M W	CASTELLON, H G	TBATBA
<i>(13 Week Class Starts 9/20/2010, Ends 12/19/2010)</i>				
8731	LEC 8:00 am - 12:15 pm	TWThF	CORSO, M E	JOB CORP
<i>(2 Week Class Starts 10/12/2010, Ends 10/22/2010)</i>				
8733	LEC 8:00 am - 11:20 am	MTWThF	HILL, V M	JOB CORP
<i>(2 Week Class Starts 9/27/2010, Ends 10/9/2010)</i>				

ESL CIVICS 010CE

5754	LEC 1:40 hrs	TBA	STAFF	TBA TBA
<i>(10 Week Class Starts 10/14/2010, Ends 12/19/2010)</i>				

ESL CIVICS 012CE

8801	LEC 4:15 hrs	TBA	SHISHIKYAN, A S	OFF CAM
<i>(12 Week Class Starts 9/27/2010, Ends 12/19/2010)</i>				

SECTION#	TIME	DAYS	INSTRUCTOR	LOCATION
ESL CIVICS 013CE				
5733	LEC 5:10 hrs	TBA	SHISHIKYAN, A S	OFF CAM
<i>(10 Week Class Starts 10/13/2010, Ends 12/19/2010)</i>				
8724	LEC 9:00 am - 1:00 pm	TPARK	MOON, C W	KSNR CNTR
<i>(14 Week Class Starts 9/18/2010, Ends 12/19/2010)</i>				
8811	LEC 5:30 pm - 6:55 pm	T Th F	SHISHIKYAN, A S	HOLL YFC
<i>(12 Week Class Starts 9/30/2010, Ends 12/19/2010)</i>				
8812	LEC 9:00 am - 10:50 am	T Th	ARRELLANO, P E	JOB CORP
<i>(14 Week Class Starts 9/13/2010, Ends 12/19/2010)</i>				
8814	LEC 12:20 pm - 4:35 pm	W	AMARO, A	CCW 255
<i>(12 Week Class Starts 9/29/2010, Ends 12/19/2010)</i>				
8885	LEC 6:00 pm - 9:35 pm	T	CHUNG, J	KRSC CNTR
<i>(14 Week Class Starts 9/14/2010, Ends 12/19/2010)</i>				

ESL CIVICS 014CE

5804	LEC 4:00 pm - 7:00 pm	T Th	RUTA, R	TBA TBA
<i>(9 Week Class Starts 9/18/2010, Ends 11/18/2010)</i>				
5805	LEC 1:00 pm - 5:00 pm	M	AMARO, A	CCW 255
<i>(13 Week Class Starts 9/20/2010, Ends 12/19/2010)</i>				
8720	LEC 5:50 hrs	TBA	RUTA, R	TBA TBA
<i>(9 Week Class Starts 9/18/2010, Ends 11/18/2010)</i>				
8725	LEC 9:00 am - 1:15 pm	Th	PARK MOON, C W	KSNR CNTR
<i>(13 Week Class Starts 9/18/2010, Ends 12/19/2010)</i>				
8803	LEC 5:00 pm - 9:15 pm	Th	AMARO, A	CCW 258
<i>(12 Week Class Starts 9/20/2010, Ends 12/19/2010)</i>				
8806	LEC :58 hrs	TBA	AMARO, A	OFF CAMP
<i>(13 Week Class Starts 9/20/2010, Ends 12/19/2010)</i>				

ESL CIVICS 015CE

5803	LEC 5:00 pm - 9:00 pm	T	AMARO, A	CCW 258
<i>(13 Week Class Starts 9/20/2010, Ends 12/19/2010)</i>				

ESL CIVICS 031CE

8818	LEC 5:00 pm - 8:30 pm	T Th	WATIER, E R	CCW 257
<i>(15 Week Class Starts 8/30/2010, Ends 12/11/2010)</i>				

VOCATIONAL EDUCATION 002CE

5725	LAB 8:00 hrs	TBA	STAFF	OFF CAMP
AND	LAB 3:55 hrs	TBA	STAFF	OFF CAMP
<i>(11 Week Class Starts 10/4/2010, Ends 12/19/2010)</i>				

VOCATIONAL EDUCATION 003CE

5720	LEC 5:00 pm - 6:10 pm	W	VALENCIA, S E	COFE MNOR
AND	LAB 6:10 pm - 8:40 pm	W	VALENCIA, S E	COFE MNOR
<i>(14 Week Class Starts 9/11/2010, Ends 12/19/2010)</i>				
8710	LEC 1:00 pm - 2:20 pm	T	KIM, H	CCW 246
AND	LAB 2:20 pm - 5:25 pm	T	KIM, H	CCW 246
<i>(11 Week Class Starts 10/5/2010, Ends 12/19/2010)</i>				
8797	LEC 2:05 hrs	TBA	MARQUEZ, R	CCW 246
AND	LEC 6:30 hrs	TBA	MARQUEZ, R	CCW 246
<i>(8 Week Class Starts 8/30/2010, Ends 10/23/2010)</i>				
8819	LEC 2:15 pm - 3:00 pm	WTh	YALAMOVA, V G	BUNG B10
AND	LAB 3:00 pm - 4:30 pm	WTh	YALAMOVA, V G	BUNG B10
<i>(11 Week Class Starts 9/13/2010, Ends 11/27/2010)</i>				
8875	LEC 1:00 pm - 2:10 pm	Th	KIM, H	CCW 246
AND	LAB 2:10 pm - 4:40 pm	Th	KIM, H	CCW 246
<i>(13 Week Class Starts 9/16/2010, Ends 12/19/2010)</i>				
8876	LEC 9:00 am - 10:10 am	S	KIM, H	CCW 246
AND	LAB 10:10 am - 12:40 pm	S	KIM, H	CCW 246
<i>(13 Week Class Starts 9/18/2010, Ends 12/19/2010)</i>				
8934	LEC 2:15 pm - 2:55 pm	MT F	YALAMOVA, V G	BUNG B10
AND	LAB 2:55 pm - 4:15 pm	MT F	YALAMOVA, V G	BUNG B10
<i>(8 Week Class Starts 8/30/2010, Ends 10/23/2010)</i>				
8937	LEC 2:00 pm - 3:10 pm	Th	VALENCIA, S E	COFE MNOR
AND	LAB 3:10 pm - 5:40 pm	Th	VALENCIA, S E	COFE MNOR
<i>(14 Week Class Starts 9/11/2010, Ends 12/19/2010)</i>				

VOCATIONAL EDUCATION 230CE

5707	LEC6:05 hrs	TBA	STAFF	TBA TBA
<i>(2 Week Class Starts 9/6/2010, Ends 9/17/2010)</i>				
5710	LEC 0:25 hrs	TBA	YALAMOVA, V G	TBA TBA
<i>(14 Week Class Starts 9/13/2010, Ends 12/18/2010)</i>				
5713	LEC 0:21 hrs	TBA	INFANTE, M	SEIU INTE
<i>(15 Week Class Starts 9/11/2010, Ends 12/19/2010)</i>				
5732	LEC 0:28 hrs	TBA	INFANTE, M	SEIU INTE
<i>(11 Week Class Starts 10/7/2010, Ends 12/19/2010)</i>				
5737	LEC 1:00 hrs	TBA	MARTI, K V	OFF CAMP
<i>(5 Week Class Starts 10/11/2010, Ends 11/10/2010)</i>				
5811	LEC 1:00 hrs	TBA	EK, K	OFF CAMP
<i>(5 Week Class Starts 10/13/2010, Ends 11/12/2010)</i>				

SECTION#	TIME	DAYS	INSTRUCTOR	LOCATION	
5822	LEC	2:55 hrs	TBA	THOMPSON, A S	URBN LG
<i>(2 Week Class Starts 10/4/2010, Ends 10/15/2010)</i>					
5824	LEC	6:00 hrs	TBA	JULIEN, J K	OFF CAMP
<i>(1 Week Class Starts 10/25/2010, Ends 10/29/2010)</i>					
8719	LEC	1:00 hrs	TBA	STAFF	OFF CAMP
<i>(5 Week Class Starts 10/11/2010, Ends 11/10/2010)</i>					
8737	LEC	0:28 hrs	TBA	INFANTE, M	CCW 259
<i>(11 Week Class Starts 10/4/2010, Ends 12/19/2010)</i>					
8761	LEC	8:00 am - 8:40 am	T	STAFF	TBA TBA
<i>(8 Week Class Starts 9/20/2010, Ends 11/14/2010)</i>					
8770	LEC	2:00 pm - 2:20 pm	WTh	MORA, F P	CCW 260
<i>(10 Week Class Starts 9/14/2010, Ends 11/21/2010)</i>					
8834	LEC	1:00 pm 2:15 pm	Th	CORSO, M E	OFF CAMP
<i>(5 Week Class Starts 9/27/2010, Ends 10/25/2010)</i>					
8835	LEC	1:00 pm 2:15 pm	T	CORSO, M E	OFF CAMP
<i>(4 Week Class Starts 9/29/2010, Ends 10/26/2010)</i>					
8839	LEC	9:00 am 3:05 pm	Th	MARTI, K V	HH 107
<i>(1 Week Class Starts 9/23/2010, Ends 9/23/2010)</i>					
8841	LEC	9:00 am 3:00 pm	Th	MARTI, K V	HH 107
<i>(1 Week Class Starts 10/21/2010, Ends 10/21/2010)</i>					
8842	LEC	9:00 am 3:05 pm	Th	MARTI, K V	HH 107
<i>(1 Week Class Starts 11/4/2010, Ends 11/4/2010)</i>					
8843	LEC	9:00 am 3:00 pm	Th	STAFF	TBA TBA
<i>(1 Week Class Starts 12/9/2010, Ends 12/9/2010)</i>					
8860	LEC	1:00 hrs	TBA	SHISHIKYAN, A S	OFF CAMP
<i>(5 Week Class Starts 9/17/2010, Ends 10/17/2010)</i>					
8868	LEC	0:30 hrs	TBA	ARRELLANO, P E	OFF CAMP
<i>(10 Week Class Starts 10/13/2010, Ends 12/19/2010)</i>					
8873	LEC	0:21 hrs	TBA	INFANTE, M	SEIU INTE
<i>(15 Week Class Starts 9/11/2010, Ends 12/19/2010)</i>					
8902	LEC	0:40 hrs	TBA	HILL, V M	OFF CAMP
<i>(8 Week Class Starts 9/10/2010, Ends 10/29/2010)</i>					
8906	LEC	12:40 pm - 1:05 pm	MTWTh	SIMPSON, A S	URBN LG
<i>(4 Week Class Starts 9/9/2010, Ends 10/2/2010)</i>					
8915	LEC	0:50 hrs	TBA	STAFF	OFF CAMP
<i>(6 Week Class Starts 11/1/2010, Ends 12/6/2010)</i>					
8919	LEC	0:22 hrs	TBA	AMARO, A	CCW 246
<i>(14 Week Class Starts 9/13/2010, Ends 12/19/2010)</i>					
VOCATIONAL EDUCATION 232CE					
8854	LEC	0:40 hrs	TBA	CORSO, M E	OFF CAMP
<i>(5 Week Class Starts 9/29/2010, Ends 10/30/2010)</i>					
VOCATIONAL EDUCATION 233CE					
8852	LEC	0:50 hrs	TBA	CORSO, M E	OFF CAMP
<i>(5 Week Class Starts 9/29/2010, Ends 10/30/2010)</i>					
VOCATIONAL EDUCATION 234CE					
8856	LEC	1:10 hrs	TBA	CORSO, M E	OFF CAMP
<i>(5 Week Class Starts 9/29/2010, Ends 10/30/2010)</i>					
8857	LEC	2:05 hrs	TBA	STAFF	TBA TBA
<i>(3 Week Class Starts 10/11/2010, Ends 10/27/2010)</i>					
VOCATIONAL EDUCATION 235CE					
8853	LEC	1:00 hrs	TBA	CORSO, M E	OFF CAMP
<i>(5 Week Class Starts 9/29/2010, Ends 10/30/2010)</i>					
VOCATIONAL EDUCATION 236CE					
5703	LEC	0:40 hrs	TBA	ARRELLANO, P E	OFF CAMP
<i>(8 Week Class Starts 10/25/2010, Ends 12/19/2010)</i>					
5708	LEC	0:25 hrs	TBA	YALAMOVA, V G	BUNG B10
<i>(14 Week Class Starts 9/13/2010, Ends 12/18/2010)</i>					
5711	LEC	6:05 hrs	TBA	STAFF	OFF CAMP
<i>(1 Week Class Starts 10/8/2010, Ends 10/9/2010)</i>					
5714	LEC	8:40 am - 9:20 am	T	STAFF	TBA TBA
<i>(8 Week Class Starts 9/20/2010, Ends 11/14/2010)</i>					
5721	LEC	5:40 pm - 6:05 pm	W	INFANTE, M	CCW 259
<i>(14 Week Class Starts 9/11/2010, Ends 12/19/2010)</i>					
5727	LEC	1:20 pm - 1:45 pm	F	INFANTE, M	CCW 259
<i>(14 Week Class Starts 9/11/2010, Ends 12/19/2010)</i>					
5728	LEC	0:20 hrs	TBA	INFANTE, M	SEIU INTE
<i>(15 Week Class Starts 9/11/2010, Ends 12/19/2010)</i>					
5738	LEC	1:00 hrs	TBA	MARTI, K V	OFF CAMP
<i>(5 Week Class Starts 10/11/2010, Ends 11/10/2010)</i>					
5740	LEC	0:21 hrs	TBA	INFANTE, M	SEIU INTE
<i>(15 Week Class Starts 9/11/2010, Ends 12/19/2010)</i>					
5750	LEC	0:20 hrs	TBA	INFANTE, M	SEIU INTE
<i>(15 Week Class Starts 9/11/2010, Ends 12/19/2010)</i>					
5751	LEC	2:55 hrs	TBA	STAFF	TBA TBA

SECTION#	TIME	DAYS	INSTRUCTOR	LOCATION	
<i>(2 Week Class Starts 9/20/2010, Ends 10/2/2010)</i>					
5815	LEC	1:00 hrs	TBA	EK, K	OFF CAMP
<i>(5 Week Class Starts 10/13/2010, Ends 11/12/2010)</i>					
5819	LEC	0:31 hrs	TBA	STAFF	CCW 260
<i>(10 Week Class Starts 9/14/2010, Ends 11/21/2010)</i>					
8729	LEC	1:00 hrs	TBA	THOMPSON, A S	URBN LG
<i>(2 Week Class Starts 10/4/2010, Ends 10/16/2010)</i>					
8738	LEC	0:28 hrs	TBA	INFANTE, M	CCW 259
<i>(11 Week Class Starts 10/4/2010, Ends 12/19/2010)</i>					
8786	LEC	1:05 hrs	TBA	SHISHIKYAN, A S	AD 303
<i>(5 Week Class Starts 9/17/2010, Ends 10/17/2010)</i>					
8866	LEC	1:00 hrs	TBA	SHISHIKYAN, A S	OFF CAMP
<i>(5 Week Class Starts 10/18/2010, Ends 11/19/2010)</i>					
8874	LEC	12:50 pm - 1:15 pm	F	INFANTE, M	CCW 259
<i>(14 Week Class Starts 9/11/2010, Ends 12/19/2010)</i>					
8881	LEC	0:30 hrs	TBA	CORSO, M E	CCW 238
<i>(10 Week Class Starts 9/20/2010, Ends 11/22/2010)</i>					
8903	LEC	0:40 hrs	TBA	HILL, V M	OFF CAMP
<i>(8 Week Class Starts 9/10/2010, Ends 10/29/2010)</i>					
8907	LEC	1:15 hrs	TBA	THOMPSON, A S	URBN LG
<i>(4 Week Class Starts 9/9/2010, Ends 10/2/2010)</i>					
8916	LEC	0:50 hrs	TBA	STAFF	OFF CAMP
<i>(6 Week Class Starts 11/1/2010, Ends 12/6/2010)</i>					
8920	LEC	0:22 hrs	TBA	AMARO, A	CCW 246
<i>(14 Week Class Starts 9/13/2010, Ends 12/19/2010)</i>					
8924	LEC	2:25 pm - 2:40 pm	TTh	STAFF	CCW 255
<i>(14 Week Class Starts 9/13/2010, Ends 12/19/2010)</i>					
8938	LEC	9:00 am - 2:55 pm	S	CORSO, M E	OFF CAMP
<i>(1 Week Class Starts 11/5/2010, Ends 11/6/2010)</i>					
VOCATIONAL EDUCATION 237CE					
8855	LEC	1:20 hrs	TBA	CORSO, M E	OFF CAMP
<i>(5 Week Class Starts 9/29/2010, Ends 10/30/2010)</i>					
VOCATIONAL EDUCATION 238CE					
5700	LEC	4:15 hrs	TBA	ARRELLANO, P E	OFF CAMP
<i>(8 Week Class Starts 10/25/2010, Ends 12/19/2010)</i>					
5704	LEC	3:00 pm - 6:20 pm	MT	MARTI, K V	ARCH YEMP
AND	LEC	10:00 am - 12:10 pm	S	MARTI, K V	ARCH YEMP
<i>(4 Week Class Starts 11/1/2010, Ends 11/24/2010)</i>					
5726	LEC	2:00 pm - 4:30 pm	W	INFANTE, M	CCW 258
<i>(14 Week Class Starts 9/11/2010, Ends 12/19/2010)</i>					
5729	LEC	7:00 hrs	TBA	STAFF	SEIU INTE
<i>(5 Week Class Starts 10/13/2010, Ends 11/13/2010)</i>					
5730	LEC	3:05 hrs	TBA	INFANTE, M	SEIU INTE
<i>(11 Week Class Starts 10/7/2010, Ends 12/19/2010)</i>					
5734	LEC	3:20 hrs	TBA	SHISHIKYAN, A S	OFF CAMP
<i>(10 Week Class Starts 10/13/2010, Ends 12/19/2010)</i>					
5735	LEC	7:05 hrs	TBA	MARTI, K V	OFF CAMP
<i>(5 Week Class Starts 10/11/2010, Ends 11/10/2010)</i>					
5741	LEC	9:00 am - 11:30 am	F	INFANTE, M	CCW 259
<i>(14 Week Class Starts 9/11/2010, Ends 12/19/2010)</i>					
5743	LEC	2:10 hrs	TBA	INFANTE, M	SEIU INTE
<i>(15 Week Class Starts 9/11/2010, Ends 12/19/2010)</i>					
5745	LEC	17:50 hrs	TBA	THOMPSON, A S	URBN LG
<i>(2 Week Class Starts 12/6/2010, Ends 12/19/2010)</i>					
5746	LEC	11:50 hrs	TBA	THOMPSON, A S	LA CNSC
AND	LEC	11:50 hrs	TBA	THOMPSON, A S	LA CNSC
AND	LEC	11:50 hrs	TBA	THOMPSON, A S	LA CNSC
<i>(1 Week Class Starts 10/18/2010, Ends 10/22/2010)</i>					
5747	LEC	3:20 hrs	TBA	JOHNSON, K S	TBA TBA
<i>(15 Week Class Starts 9/6/2010, Ends 12/19/2010)</i>					
5748	LEC	4:55 hrs	TBA	TORUNO, O	OFF CAMP
<i>(7 Week Class Starts 11/1/2010, Ends 12/19/2010)</i>					
5814	LEC	4:00 pm - 6:20 pm	MW	EK, K	TBA TBA
<i>(7 Week Class Starts 9/13/2010, Ends 10/30/2010)</i>					
5817	LEC	9:00 am - 1:15 pm	MTWTh	THOMPSON, A S	URBN LG
<i>(2 Week Class Starts 10/4/2010, Ends 10/16/2010)</i>					
8717	LEC	10:00 am - 12:50 pm	Th	GARCIA, V A	TBA TBA
<i>(13 Week Class Starts 9/17/2010, Ends 12/19/2010)</i>					
8736	LEC	9:00 am - 12:20 pm	S	INFANTE, M	CCW 259
<i>(10 Week Class Starts 10/4/2010, Ends 12/19/2010)</i>					
8773	LEC	8:00 am - 11:50 am	MTWThF	HILL, V M	JOB CORP
<i>(2 Week Class Starts 8/30/2010, Ends 9/11/2010)</i>					
8776	LEC	9:00 am - 12:50 pm	MTWThF	STAFF	TBA TBA
<i>(2 Week Class Starts 9/6/2010, Ends 9/18/2010)</i>					

SECTION#	TIME	DAYS	INSTRUCTOR	LOCATION
8777	LEC 8:00 am - 12:15 pm	TWThF	STAFF	TBA TBA
<i>(2 Week Class Starts 9/20/2010, Ends 10/2/2010)</i>				
8779	LEC 3:00 pm - 5:25 pm	MT	MARTI, K V	ARCH YEMP
AND	LEC 10:00 am - 2:30 pm	S	MARTI, K V	ARCH YEMP
<i>(4 Week Class Starts 9/27/2010, Ends 10/20/2010)</i>				
8781	LEC 8:00 am - 11:20 am	MTWThF	STAFF	JOB CORP
<i>(2 Week Class Starts 10/11/2010, Ends 10/23/2010)</i>				
8782	LEC 8:00 am - 11:20 am	MTWThF	HILL, V M	JOB CORP
<i>(2 Week Class Starts 10/25/2010, Ends 11/6/2010)</i>				
8783	LEC 8:00 am - 11:50 am	MTWThF	HILL, V M	JOB CORP
<i>(2 Week Class Starts 11/8/2010, Ends 11/19/2010)</i>				
8784	LEC 8:00 am - 12:15 pm	MTWThF	HILL, V M	JOB CORP
<i>(2 Week Class Starts 11/22/2010, Ends 12/3/2010)</i>				
8858	LEC 7:00 hrs	TBA	SHISHIKYAN, A S	OFF CAMP
<i>(5 Week Class Starts 9/17/2010, Ends 10/17/2010)</i>				
8863	LEC 7:00 hrs	TBA	STAFF	OFF CAMP
<i>(5 Week Class Starts 10/18/2010, Ends 11/19/2010)</i>				
8867	LEC 7:00 hrs	TBA	SHISHIKYAN, A S	OFF CAMP
<i>(5 Week Class Starts 9/17/2010, Ends 10/17/2010)</i>				
8871	LEC 3:00 pm - 5:50 pm	F	COLON, N	SEIU INTE
<i>(13 Week Class Starts 9/13/2010, Ends 12/13/2010)</i>				
8901	LEC 8:00 am - 11:20 am	MTWThF	HILL, V M	JOB CORP
<i>(2 Week Class Starts 9/13/2010, Ends 9/25/2010)</i>				
8909	LEC 9:00 am - 11:30 am	MTWTh	THOMPSON, A S	URBN LG
<i>(4 Week Class Starts 9/9/2010, Ends 10/2/2010)</i>				
8914	LEC 10:00 am - 12:50 pm	F	GARCIA, V A	TBA TBA
<i>(12 Week Class Starts 9/20/2010, Ends 12/19/2010)</i>				
8918	LEC 4:00 pm - 6:10 pm	M W	STAFF	TBA TBA
<i>(8 Week Class Starts 9/6/2010, Ends 10/30/2010)</i>				
8925	LEC 5:00 hrs	TBA	STAFF	OFF CAMP
<i>(7 Week Class Starts 10/10/2010, Ends 11/27/2010)</i>				
8940	LEC 8:00 am - 1:50 pm	F	CORSO, M E	AD 301B
<i>(6 Week Class Starts 11/5/2010, Ends 12/17/2010)</i>				
8943	LEC 2:00 pm - 5:20 pm	T	STAFF	CCW 260
<i>(10 Week Class Starts 8/30/2010, Ends 11/6/2010)</i>				

VOCATIONAL EDUCATION 239CE

5702	LEC 2:50 hrs	TBA	SHISHIKYAN, A S	CCW 259
<i>(6 Week Class Starts 11/8/2010, Ends 12/19/2010)</i>				
5705	LEC 2:05 hrs	TBA	INFANTE, M	SEIU INTE
<i>(8 Week Class Starts 10/7/2010, Ends 11/27/2010)</i>				
5709	LEC 1:00 pm - 2:50 pm	MTWThF	STAFF	TBA TBA
<i>(2 Week Class Starts 9/6/2010, Ends 9/17/2010)</i>				
5712	LEC 1:05 hrs	TBA	COLON, N	SEIU INTE
<i>(14 Week Class Starts 9/13/2010, Ends 12/19/2010)</i>				
5719	LEC 7:30 hrs	TBA	STAFF	TBA TBA
<i>(2 Week Class Starts 9/20/2010, Ends 10/2/2010)</i>				
5731	LEC 1:00 hrs	TBA	INFANTE, M	SEIU INTE
<i>(15 Week Class Starts 9/11/2010, Ends 12/19/2010)</i>				
5736	LEC 3:20 hrs	TBA	MARTI, K V	OFF CAMP
<i>(5 Week Class Starts 10/11/2010, Ends 11/10/2010)</i>				
5739	LEC 1:30 hrs	TBA	ARRELLANO, P E	OFF CAMP
<i>(10 Week Class Starts 10/13/2010, Ends 12/19/2010)</i>				
5742	LEC 4:30 pm - 5:40 pm	W	INFANTE, M	CCW 259
<i>(14 Week Class Starts 9/11/2010, Ends 12/19/2010)</i>				
5744	LEC 3:20 hrs	TBA	STAFF	SEIU INTE
<i>(5 Week Class Starts 11/15/2010, Ends 12/19/2010)</i>				
5810	LEC 6:25 pm - 7:30 pm	M W	EK, K	TBA TBA
<i>(8 Week Class Starts 9/10/2010, Ends 10/30/2010)</i>				
5821	LEC 1:20 pm - 3:25 pm	MTWTh	THOMPSON, A S	URBN LG
<i>(2 Week Class Starts 10/4/2010, Ends 10/16/2010)</i>				
5823	LEC 17:50 hrs	TBA	STAFF	OFF CAMP
<i>(1 Week Class Starts 10/25/2010, Ends 10/29/2010)</i>				
5833	LEC 6:20 pm - 7:50 pm	M W F	STAFF	HOLL PRES
<i>(4 Week Class Starts 11/1/2010, Ends 11/26/2010)</i>				
5836	LEC 3:30 pm - 6:50 pm	MTWThF	TORUNO, O	TBA TBA
<i>(1 Week Class Starts 11/1/2010, Ends 11/6/2010)</i>				
8718	LEC 11:00 am - 11:35 am	T Th	STAFF	CCW 255
<i>(14 Week Class Starts 9/13/2010, Ends 12/19/2010)</i>				
8739	LEC 1:22 hrs	TBA	INFANTE, M	CCW 259
<i>(11 Week Class Starts 10/4/2010, Ends 12/19/2010)</i>				
8769	LEC 8:00 am - 10:00 am	MTWThF	CALLERA, G P	JOB CORP
<i>(2 Week Class Starts 8/31/2010, Ends 9/11/2010)</i>				
8832	LEC 2:30 pm - 6:45 pm	W	CORSO, M E	OFF CAMP
<i>(5 Week Class Starts 9/27/2010, Ends 10/25/2010)</i>				
8833	LEC 1:50 pm - 3:55 pm	W	MARTI, K V	ARCH YEMP
<i>(8 Week Class Starts 9/27/2010, Ends 11/24/2010)</i>				

SECTION#	TIME	DAYS	INSTRUCTOR	LOCATION
8862	LEC 8:00 am - 10:05 am	F	STAFF	TBA TBA
<i>(8 Week Class Starts 9/20/2010, Ends 11/14/2010)</i>				
8872	LEC 11:35 am - 12:45 pm	F	INFANTE, M	CCW 259
<i>(14 Week Class Starts 9/11/2010, Ends 12/19/2010)</i>				
8886	LEC 1:30 hrs	TBA	CORSO, M E	CCW 238
<i>(10 Week Class Starts 9/20/2010, Ends 11/22/2010)</i>				
8887	LEC 8:00 am - 9:30 am	MTWThF	CALLERA, G P	JOB CORP
<i>(2 Week Class Starts 9/13/2010, Ends 9/25/2010)</i>				
8889	LEC 8:00 am - 9:30 am	MTWThF	CALLERA, G P	JOB CORP
<i>(2 Week Class Starts 9/27/2010, Ends 10/9/2010)</i>				
8891	LEC 8:00 am - 9:30 am	MTWThF	CALLERA, G P	JOB CORP
<i>(2 Week Class Starts 10/11/2010, Ends 10/23/2010)</i>				
8893	LEC 8:00 am - 9:30 am	MTWThF	CALLERA, G P	JOB CORP
<i>(2 Week Class Starts 10/25/2010, Ends 11/6/2010)</i>				
8895	LEC 8:00 am - 9:50 am	MTWThF	CALLERA, G P	JOB CORP
<i>(2 Week Class Starts 11/8/2010, Ends 11/20/2010)</i>				
8897	LEC 8:00 am - 10:20 am	MTWTh	STAFF	JOB CORP
<i>(2 Week Class Starts 11/22/2010, Ends 12/4/2010)</i>				
8899	LEC 8:00 am - 9:30 am	MTWThF	STAFF	JOB CORP
<i>(2 Week Class Starts 12/6/2010, Ends 12/19/2010)</i>				
8904	LEC 2:00 hrs	TBA	HILL, V M	JOB CORP
<i>(8 Week Class Starts 9/10/2010, Ends 10/29/2010)</i>				
8905	LEC 11:30 am - 12:40 pm	MTWTh	THOMPSON, A S	URBN LG
<i>(4 Week Class Starts 9/9/2010, Ends 10/2/2010)</i>				
8917	LEC 1:00 hrs	TBA	JOHNSON, K S	TBA TBA
<i>(15 Week Class Starts 9/6/2010, Ends 12/19/2010)</i>				
8921	LEC 2:20 hrs	TBA	STAFF	TBA TBA
<i>(7 Week Class Starts 11/1/2010, Ends 12/17/2010)</i>				
8941	LEC 1:10 hrs	TBA	AMARO, A	CCW 246
<i>(13 Week Class Starts 9/20/2010, Ends 12/19/2010)</i>				
8946	LEC 10:00 am - 2:15 pm	S	THOMPSON, A S	JOB CORP
<i>(5 Week Class Starts 11/8/2010, Ends 12/17/2010)</i>				
VOCATIONAL EDUCATION 241CE				
8787	LEC 0:38 hrs	TBA	CORSO, M E	CCW 259
<i>(8 Week Class Starts 8/30/2010, Ends 10/23/2010)</i>				





The Weekend College

A Program of Los Angeles Community College District

ITV The Weekend College classes allow students to complete general education classes in a focused eight-week format. Classes are taught on four campuses: **City [C]** and **Southwest [SW]** Colleges on Saturdays and **Valley [V]** and **Pierce [P]** Colleges on Sundays. First college listed is **AM only 9:00 - 12:00 Noon**. Second college listed is **PM only 1:30 - 4:30 PM**. Students may attend at any location or change locations, if necessary, throughout the semester.

The classes are taught by the same qualified LACCD instructor at each campus. Instruction is combined with award-winning video lessons available on cable television, in broadband, on DVD, and in the College Learning Resource Centers. Each class also has an online component creating a positive, engaging learning environment.

For classroom locations go to:

www.lamission.edu/itv and click View Schedule. Financial aid is available for qualified students; fee waivers apply to these classes. Transcripts are issued by LA Mission College.

Fall 2010 Session A August 30 - October 24, 2010

Classes	Section	Saturday Campus	Sunday Campus
Economics 1	7084	C/SW	P/V
English 101	7085	C/SW	P/V
Health 11	7086	C/SW	P/V
History 11	7087	C/SW	P/V
Oceanography 1	7088	SW/C	V/P
Philosophy 1	7089	SW/C	V/P
Political Science 1	7090	SW/C	V/P
Psychology 1	7091	SW/C	V/P

Saturday class meetings: September 4 – October 23
Sunday class meetings: September 5 – October 24

Last Day To:
ADD Classes: September 9, 2010
Drop without incurring fees: September 4, 2010

Summer 2010 June 14 - August 1, 2010

Classes	Section	Saturday Campus	Sunday Campus
Economics 1	7074	C/SW	P/V
English 101	7075	C/SW	P/V
Health 11	7076	C/SW	P/V
History 11	7077	C/SW	P/V
Math 125	7078	C/SW	P/V
Oceanography 1	7079	SW/C	V/P
Philosophy 1	7080	SW/C	V/P
Political Science 1	7081	SW/C	V/P
Psychology 41	7082	SW/C	V/P
Sociology 1	7083	SW/C	V/P

Saturday class meetings: June 19 – July 31
Sunday class meetings: June 20 – August 1
No class meetings: July 4 & 5

Last Day To:
ADD Classes: June 23, 2010
Drop without incurring fees: June 18, 2010

Fall 2010 Session B October 25 - December 19, 2010

Classes	Section	Saturday Campus	Sunday Campus
English 101	7092	C/SW	P/V
English 102	7093	C/SW	P/V
Health 11	7094	C/SW	P/V
History 11	7095	C/SW	P/V
Math 125	7096	SW/C	V/P
Philosophy 1	7097	SW/C	V/P
Political Science 1	7098	SW/C	V/P
Psychology 41	7099	SW/C	V/P
Sociology 1	7100	SW/C	V/P

Saturday class meetings: October 30 – December 18
Sunday class meetings: October 31 – December 19
No class meetings: November 27 & 28

Last Day To:
ADD Classes: November 4, 2010
Drop without incurring fees: October 30, 2010

Website: www.lamission.edu/itv • Telephone: 818/833-3594 or 800/917-9277

Ralph Bunche Scholars Program



If you are planning to transfer to a four-year university,



consider joining the Ralph Bunche Scholars College.

The Scholars Program is designed to prepare the motivated student for transfer. The program's enriched and rigorous curriculum challenges academically motivated and intellectually curious students. Students may have the opportunity to participate in tutoring and research. These experiences will lead beyond the community college, through the four-year school, and into the professional lives of these scholars.

- UCLA
- UC Irvine
- UC Riverside
- UC Santa Cruz
- CSU Long Beach
- CSU Fullerton
- Chapman University
- Columbia University
- Mills College
- La Sierra University
- Occidental College
- Pacific University
- Pitzer College
- Pomona College
- Whitman College

HOW TO JOIN:

You need to have a 3.25 GPA minimum (high school or college) and be eligible for English 101 and Math 125.

HOW TO CERTIFY:

You must complete 18 units (6 classes) of Honors coursework with an overall 3.3 GPA

WHAT TO EXPECT:

An intense program of reading and writing, LACC priority admissions, scholarships, social events, field trips, UCLA and UCI library privileges, and more.



TO APPLY CONTACT:

Program Director:
AD 205B/C (323)953-4000, x 2705 and 2340

Or visit the Web site:

<http://www.lacitycollege.edu/services/honorsprogram>

Course	Days	Instructor	Room
African American Studies 4 LEC 9:00-10:25AM	TTh	Eckford	FH 221
Anthropology 101 LEC 10:35-12:00PM	MW	Bartelt	FH B22
Anthropology 102 LEC 9:00-10:25AM	TTh	Bartelt	FH B22
Astronomy 1 LEC 10:35-12:00PM	TTh	McCudden	SCI 132
Biology 6 LEC 12:10-1:35PM & LAB 1:35-4:45PM	MW TTh	Phommasaysy Phommasaysy	SCI 130
Chemistry 101 LEC 5:15-6:40PM LEC 6:50-7:50PM LAB 7:55-10:00PM	MW MW MW	Torres Torres Torres	SCI 314 SCI 314 SCI 306
Chicano Studies 7 (on-line)	TBS	Guerrero	TBA
English 101 LEC 10:35-12:00PM LEC 10:35-12:00PM	MW TTh	Muller Miklos	TBA TBA
English 102 LEC 10:35-12:00PM	MW	Nishimura	TBA
English 203 LEC 10:35-12:00PM	TTh	Muller	TBA
History 11 LEC 9:00-10:25AM	MW	Eckford	FH 210
History 7 LEC 10:35-12:00PM	TTh	Eckford	FH 221
Mathematics 227 LEC 1:45-3:50PM LEC 10:35-12:00PM LEC 9:00-10:25AM	MTW MWF MTW	Sow Badalian Plotquin	FH 121 FH 310 FH 301
Mathematics 261 LEC 9:00-10:10AM LEC 7:00-9:30PM LEC 10:35-11:45AM	MTWTh TTh MTWTh	Mardirosian Nikolaychuk Sow	FH 120 FH 116 FH 112
Mathematics 262 LEC 9:00-10:10AM LEC 7:00-9:30PM	MTWTh MW	Kaviani Lee	FH 121 FH 120
Mathematics 263 LEC 10:35-11:45AM LEC 7:00-9:00PM	MTWTh TTh	Nikolaychuk Lee	FH 120 FH 120
Music 111 LEC 6:50-10PM	T	Dutton	CH 247
Philosophy 1 LEC 9:00-10:25AM	MW	Torres	HH 202
Philosophy 14 LEC 10:35-12:00PM	TTh	Torres	HH 202
Physics 11 LEC 12:10-3:20PM LAB 12:10-3:20PM	T Th	Erickson Erickson	SCI 208 SCI 208
Political Science 1 LEC 12:10-1:35PM	MW	Aaron	FH 214
Sociology 1 LEC 9:00-10:25AM	TTh	Clark	FH 216

Supplemental Instruction (SI)



Supplemental Instruction (SI) is a form of peer tutoring and mentoring offered to students enrolled in historically difficult courses. It is an academic assistance program that increases student performance and retention. It has proven effective in helping students earn higher final course grades than students not participating in the program.

An **SI** mentor (a student selected by the instructor who has previously taken the course and demonstrated proficiency in the subject matter) provides students with supplemental information on lectures, tests and assignments. Mentors attend every class session and conduct three to five , fifty minute study groups each week at times convenient to the majority of students to review lecture material. Sessions normally occur in or near the course classroom instead of in a learning center. Sessions are attended on a voluntary basis and students are not segregated based on academic ability. Since **SI** is introduced on the first day of classes and is open to all students in the class, its in no way viewed as remedial. Mentors may also be reached via telephone or e-mail and provide students with supplemental information.

To the right, is a list of Spring 2010 classes with **Supplemental Instruction**. So, take advantage of **SI** sections by enrolling early! These sections are identified in the schedule of classes by a note stating “ Special tutorial assistance available in section”.

SECTION #	CLASS
5002	Anatomy 1
8003	Anatomy
0203	Biology 3
5037	Chemistry 60
3106	Child Development
0378	Economics 1
0426	English 28
0433	English 28
0184	English 97
0185	English 97
0194	English 97
0197	English 97
0202	English 97
3020	English 97
0414	English 20
1733	ESL 6A
0852	Math 112
0856	Math 112
0857	Math 112
0840	Math 112
0868	Math 115
0920	Math 115
0864	Math 115
0865	Math 115
0866	Math115
0867	Math 115
3412	Math 115
0935	Music 101
8493	Physiology 1
1268	Speech 121



Degree & Certificate Program



ACCOUNTING

Degrees: Accounting, Bookkeeping
Certificates: Accounting Technician, Automated Accounting

ADMINISTRATION OF JUSTICE

Degrees: Administration Of Justice, AJ - Specializing in Forensics
Certificates: Correctional Institution Officer Training, Evidence Technician/Forensics, Finger Print Classification, Fire Arms Training, Private Investigation

ART

Degrees: Art-General, Art- Graphic Design

BUSINESS

Degrees: Advertising, Business Administration, Finance and Banking, Management, Business Offices, Management Small Business, Marketing/Sales
Certificates: Business Administration, Microcomputer Business Applications, Finance and Banking, Management, Management - Retail, Management - Small Business, Marketing/Sales

CHEMISTRY

Degrees: Chemistry - General

CHICANO STUDIES

Degrees: Chicano Studies

CHILD DEVELOPMENT

Degrees: Child Development Plan A or B
Certificates: Child Dev Teacher, Child Dev Teacher - Master Teacher, Child Dev Site Supervisor, Child Dev Associate Teacher, Children with Special Needs, Infant And Toddler Studies, School Age Programs

CINEMA

Degrees: Cinema Production, Television Production
Certificates: Cinema Production, Television Production, Cinema Video Production, Beginning Cinema & TV Production, Cinema Post- Production, Cinematography, TV Studio Production - Level 1

COMPUTER APPS & OFFICE TECH

Degrees: Administrative Office Assistant, Computer Applications Specialist, Legal Office Assistant, Medical Office Assistant
Certificates: Administrative Office Assistant, Computer Applications Specialist, Legal Office Assistant, Medical Office Assistant, Clerical Office Assistant, Basic Administrative Office Assistant, Basic Computer Applications, Basic Legal Office, Basic Medical Administrative, Basic Medical Billing, Basic Medical Transcription, Basic Office Communications, Basic Web Page Design, Basic Word Processing

COMPUTER SCIENCES / INFORMATION TECHNOLOGY (CSIT)

Degrees: Computer Science/Information Tech, Computer Information Systems

Certificates: Computer Science/Information Tech, Computer Information Systems, Applications Software, Programming Languages, UNIX Operating System, Computer Networking, Database Administration, Operating Systems, Web Client Technologies, Web Server Technologies

COMPUTER TECHNOLOGY

Degrees: Computer Technology,
Certificates: Computer Technology, CompTIA A+ Certification, CompTIA Network+ Certification

DENTAL TECHNOLOGY

Degree & Certificates: Dental Technology

ELECTRONICS

Degrees: Electronic Systems Technology (Traditional & Fast Track)
Certificates: Electronics - Basic, Electronic Systems Technology, Electronic Sys Tech - Fast Track

ENGINEERING

Degrees: Engineering - General

ENGLISH

Degrees: English

FAMILY & CONSUMER STUDIES (DIETETICS)

Degrees: Dietetic Technician
Certificates: Dietetic Service Supervisor

FOREIGN LANGUAGE

Degrees: Chinese, French, German, Italian, Japanese, Korean, Spanish

HUMANITIES

Degrees: Humanities

JOURNALISM

Degrees: Journalism

LAW

Degrees: Paralegal Studies, Business Law

LIBERAL ARTS

Degrees: Liberal Arts

MATHEMATICS

Degrees: Mathematics

MUSIC

Degrees: Music
Certificates: Music Copyist, Music Technology, Orchestrator/Arranger, Vocal Performer, Instrumental Performer (Brass, Guitar, Organ, Percussion, Piano, Strings, Woodwinds)

NURSING

Degrees: Nursing, Registered
Certificates: Certified Nurse Assistant, Home Health Aide

PHOTOGRAPHY

Degrees: Applied Photography
Certificates: Photography - Commercial, Photography- Freelance

PHYSICS

Degrees: Physics - General

POLITICAL SCIENCE

Degrees: Modern Political Studies

PSYCHOLOGY

Degrees: Human Services (Generalist & Drug/ Alcohol)
Certificates: Human Services (Generalist & Drug/ Alcohol)

RADIOLOGIC TECHNOLOGY

Degree Programs: Radiologic Technology

REAL ESTATE

Degrees: Real Estate
Certificates: Real Estate (Finance, Investment, Marketing)

SOCIAL SCIENCE

Degrees: Latin American Studies

THEATER

Degrees: Theater- General, Theatre Academy (Acting, Advanced Acting, Costuming, Technical Theater)
Certificates: Professional Technical Theater, Professional Costuming Design PHOTOGRAPHY
Degrees: Applied Photography
Certificates: Photography - Commercial, Photography- Freelance

PHYSICS

Degrees: Physics - General

POLITICAL SCIENCE

Degrees: Modern Political Studies

PSYCHOLOGY

Degrees: Human Services (Generalist & Drug/ Alcohol)
Certificates: Human Services (Generalist & Drug/ Alcohol)

RADIOLOGIC TECHNOLOGY

Degree Programs: Radiologic Technology

REAL ESTATE

Degrees: Real Estate
Certificates: Real Estate (Finance, Investment, Marketing)

SOCIAL SCIENCE

Degrees: Latin American Studies

THEATER

Degrees: Theater- General, Theatre Academy (Acting, Advanced Acting, Costuming, Technical Theater)
Certificates: Professional Technical Theater, Professional Costuming Design



Degree & Certificate Program



ACCOUNTING

Degrees: Accounting, Bookkeeping
Certificates: Accounting Technician, Automated Accounting

ADMINISTRATION OF JUSTICE

Degrees: Administration Of Justice, AJ - Specializing in Forensics
Certificates: Correctional Institution Officer Training, Evidence Technician/Forensics, Finger Print Classification, Fire Arms Training, Private Investigation

ART

Degrees: Art-General, Art- Graphic Design

BUSINESS

Degrees: Advertising, Business Administration, Finance and Banking, Management, Business Offices, Management Small Business, Marketing/Sales
Certificates: Business Administration, Microcomputer Business Applications, Finance and Banking, Management, Management - Retail, Management - Small Business, Marketing/Sales

CHEMISTRY

Degrees: Chemistry - General

CHICANO STUDIES

Degrees: Chicano Studies

CHILD DEVELOPMENT

Degrees: Child Development Plan A or B
Certificates: Child Dev Teacher, Child Dev Teacher - Master Teacher, Child Dev Site Supervisor, Child Dev Associate Teacher, Children with Special Needs, Infant And Toddler Studies, School Age Programs

CINEMA

Degrees: Cinema Production, Television Production
Certificates: Cinema Production, Television Production, Cinema Video Production, Beginning Cinema & TV Production, Cinema Post- Production, Cinematography, TV Studio Production - Level 1

COMPUTER APPS & OFFICE TECH

Degrees: Administrative Office Assistant, Computer Applications Specialist, Legal Office Assistant, Medical Office Assistant
Certificates: Administrative Office Assistant, Computer Applications Specialist, Legal Office Assistant, Medical Office Assistant, Clerical Office Assistant, Basic Administrative Office Assistant, Basic Computer Applications, Basic Legal Office, Basic Medical Administrative, Basic Medical Billing, Basic Medical Transcription, Basic Office Communications, Basic Web Page Design, Basic Word Processing

COMPUTER SCIENCES / INFORMATION TECHNOLOGY (CSIT)

Degrees: Computer Science/Information Tech, Computer Information Systems

Certificates: Computer Science/Information Tech, Computer Information Systems, Applications Software, Programming Languages, UNIX Operating System, Computer Networking, Database Administration, Operating Systems, Web Client Technologies, Web Server Technologies

COMPUTER TECHNOLOGY

Degrees: Computer Technology,
Certificates: Computer Technology, CompTIA A+ Certification, CompTIA Network+ Certification

DENTAL TECHNOLOGY

Degree & Certificates: Dental Technology

ELECTRONICS

Degrees: Electronic Systems Technology (Traditional & Fast Track)
Certificates: Electronics - Basic, Electronic Systems Technology, Electronic Sys Tech - Fast Track

ENGINEERING

Degrees: Engineering - General

ENGLISH

Degrees: English

FAMILY & CONSUMER STUDIES (DIETETICS)

Degrees: Dietetic Technician
Certificates: Dietetic Service Supervisor

FOREIGN LANGUAGE

Degrees: Chinese, French, German, Italian, Japanese, Korean, Spanish

HUMANITIES

Degrees: Humanities

JOURNALISM

Degrees: Journalism

LAW

Degrees: Paralegal Studies, Business Law

LIBERAL ARTS

Degrees: Liberal Arts

MATHEMATICS

Degrees: Mathematics

MUSIC

Degrees: Music
Certificates: Music Copyist, Music Technology, Orchestrator/Arranger, Vocal Performer, Instrumental Performer (Brass, Guitar, Organ, Percussion, Piano, Strings, Woodwinds)

NURSING

Degrees: Nursing, Registered
Certificates: Certified Nurse Assistant, Home Health Aide

PHOTOGRAPHY

Degrees: Applied Photography
Certificates: Photography - Commercial, Photography- Freelance

PHYSICS

Degrees: Physics - General

POLITICAL SCIENCE

Degrees: Modern Political Studies

PSYCHOLOGY

Degrees: Human Services (Generalist & Drug/ Alcohol)
Certificates: Human Services (Generalist & Drug/ Alcohol)

RADIOLOGIC TECHNOLOGY

Degree Programs: Radiologic Technology

REAL ESTATE

Degrees: Real Estate
Certificates: Real Estate (Finance, Investment, Marketing)

SOCIAL SCIENCE

Degrees: Latin American Studies

THEATER

Degrees: Theater- General, Theatre Academy (Acting, Advanced Acting, Costuming, Technical Theater)
Certificates: Professional Technical Theater, Professional Costuming Design PHOTOGRAPHY
Degrees: Applied Photography
Certificates: Photography - Commercial, Photography- Freelance

PHYSICS

Degrees: Physics - General

POLITICAL SCIENCE

Degrees: Modern Political Studies

PSYCHOLOGY

Degrees: Human Services (Generalist & Drug/ Alcohol)
Certificates: Human Services (Generalist & Drug/ Alcohol)

RADIOLOGIC TECHNOLOGY

Degree Programs: Radiologic Technology

REAL ESTATE

Degrees: Real Estate
Certificates: Real Estate (Finance, Investment, Marketing)

SOCIAL SCIENCE

Degrees: Latin American Studies

THEATER

Degrees: Theater- General, Theatre Academy (Acting, Advanced Acting, Costuming, Technical Theater)
Certificates: Professional Technical Theater, Professional Costuming Design

Major Codes



The following majors are offered at Los Angeles City College for which you may receive a certificate or degree. If you do not find your field of interest, you may indicate "4901.00 Liberal Art" on your enrollment application. Liberal Arts includes the Humanities and Sciences.

0502.00 Accounting	1305.12 Early Childhood Education-Teacher I	1004.00 Music
0502.00 Accounting Technician	1305.13 Early Childhood Education-Teacher II	1005.00 Music Copyist
2105.00 Administration of Justice	1305.14 Early Childhood Education-Teacher III	1203.30 Nursing: Certified Nursing Assistant
0514.00 Administrative Secretary	0934.01 Electronic Systems	1203.10 Nursing: Registered Nursing
0509.10 Advertising	0934.00 Electronics-Basic	1260.00 Nursing: Pre-Nursing and Health Related Majors-AND
0701.00 Applications Software	0901.00 Engineering	1260.01 Nursing: Pre-Nursing and Health Related Majors-BSN
0201.00 Architecture	0924.00 Engineering and Technology	0514.01 Office Administration Expert
1002.00 Art	1501.00 English	1005.03 Orchestrator/Arranger
1030.00 Art-Graphic Design	0504.00 Finance and Banking	1012.00 Photography
0502.02 Automated Accounting	1102.00 French	1012.01 Photography-Color
0934.21 Biomedical Electronics Technology	1103.00 German	1012.20 Photography-Commercial
0502.03 Bookkeeping	2104.40 Human Services-Drug/Alcohol	1012.02 Photography-Freelance
0501.00 Business Administration	2104.00 Human Services-Generalist	1902.00 Physics
1401.00 Business Law	4903.00 Humanities	0704.00 Programming Languages
0506.30 Business Office Management	1005.01 Instrumental Performer	1225.00 Radiologic Technology
0934.04 Cable Television Technology	1104.00 Italian	0511.00 Real Estate
0799.00 Certified Network Engineer	1108.00 Japanese	0511.01 Real Estate-Finance
1905.00 Chemistry	0602.00 Journalism	0511.02 Real Estate-Investment
2202.10 Chicano Studies	2202.11 Latin American Studies	0511.03 Real Estate-Marketing
1305.00 Child Development-A	1402.00 Legal Assistant/Paralegal	1306.22 School Food Services Manager
1305.00 Child Development-B	0514.10 Legal Secretary	1306.23 School Food Services Supervisor
1107.00 Chinese	4901.00 Liberal Arts	1105.00 Spanish
0612.20 Cinema Production	0506.00 Management	0604.00 Television Production
0612.20 Cinema/Video Production	0506.01 Management-Small Business	1007.00 Theatre-General
0514.02 Clerical Office Assistant	0509.51 Marketing	1007.01 Theatre Academy-Acting
0514.03 Computer Applications Specialist	0509.50 Marketing and Sales	1006.01 Theatre Academy- Costume Construction and Wardrobe Maintenance
0701.00 Computer Information Systems	1701.00 Mathematics	1006.00 Theater Academy- Stage Management and Theater Crafts
0701.04 Computer Operator	1701.01 Mathematics-Computer Science	0300.00 Undecided
0706.00 Computer Science	0514.20 Medical Secretary	1005.02 Vocal Performer
0934.03 Computer Technology	0701.03 Micro-Computer Business Applications	
2105.10 Corrections	0934.02 Microprocessor Systems Technology	
1240.30 Dental Technology	2207.00 Modern Political Studies	
1306.21 Dietetic Service Supervisor		
1306.20 Dietetic Technician		
1305.15 Early Childhood Education-Site Supervisor		

**FALL FINAL EXAMS
ARE HELD DURING THE
LAST WEEK OF CLASSES**

Final Exam Schedule

Fall schedule for final examination period from December 12-18, 2010

Day/Time	7:00-9:00 a.m.	9:30 - 11:30 a.m.	12:00 – 2:00 p.m.	2:30-4:30 p.m.	5:00 – 7:00 p.m.	7:30 – 9:30 p.m.
Monday, December 13, 2010	Classes starting between 7:00 – 7:55 a.m. MTWTh, or Mon/Wed, or starting between 7:00-8:55 a.m. Monday only	Classes starting between 10:00 – 10:55 a.m. MTWTh, or Mon/Wed, or starting between 9:00-10:55 a.m. Monday only	Classes starting between 11:00 – 11:55 p.m.. MTWTh, Mon/Wed, or starting between 11:00 a.m.-12:55 p.m. Monday only	Classes starting between 1:00 – 2:55 p.m.. MTWTh, Mon/Wed, or starting between 1:00-3:15 p.m. Monday only	Classes starting between 3:20-4:55 MTWTh, or Mon/Wed, 3:20 – 4:55 p.m. or 3:20-5:55 Monday only	Classes starting between 6:00 – 8:00 p.m. MTWTh, or Mon/Wed, or Monday only
Tuesday, December 14, 2010	Classes starting between 7:00 – 7:55 a.m. Tue/Thurs or starting between 7:00-8:55 a.m. Tuesday only	Classes starting between 10:00 – 10:55 a.m. Tue/Thurs or starting between 9:00-10:55 a.m. Tuesday only	Classes starting between 11:00 – 11:55 p.m. Tue/Thurs or starting between 11:00 a.m.-12:55 p.m. Tuesday only	Classes starting between 1:00 – 2:55 p.m. Tue/Thurs or starting between 1:00-3:15 p.m. Tuesday only	Classes starting between 3:20 – 4:55 p.m. Tue/Thur or 3:20-5:55 Tuesday only	Classes starting between 6:00 – 8:00 p.m. Tue/Thur or Tuesday only
Wednesday December 15, 2010	Classes starting between 8:00 – 8:55 a.m. MTWTh, Mon/Wed, Wed/Fri, or starting between 7:00-8:55 a.m. Wednesday only	Classes starting between 9:00 – 9:55 a.m. MTWTh, Mon/Wed, Wed./Fri, or starting between 9:00-10:55 a.m. Wednesday only	Classes starting between 12:00 – 12:55 p.m. MTWTh, Mon/Wed, Wed./Fri, or starting between 11:00 a.m.-12:55 p.m. Wednesday only	Classes starting between 1:00 – 2:55 p.m. Wed./Fri, or starting between 1:00-3:15 p.m. Wednesday only	Classes starting between 5:00-5:55 Mon/Wed or Wed Fri, or 3:20 – 5:55 p.m. Wednesday only	Classes starting between 6:00 – 8:00 p.m. Wed/Fri or Wednesday only
Thursday, December 16, 2010	Classes starting between 8:00 – 8:55 a.m. Tue/Thurs, or starting between 7:00-8:55 a.m. Thursday only	Classes starting between 9:00 – 9:55 a.m. Tue/Thurs, or starting between 9:00-10:55 a.m. Thursday only	Classes starting between 12:00 – 12:55 p.m. Tue/Thurs, or starting between 11:00 a.m.-12:55 p.m. Thursday only	Classes starting between 1:00-3:15 p.m. Thursday only	Classes starting between 5:00-5:55 Tue/Thurs or 3:20 – 5:55 p.m. Thursday only	Classes starting between 6:00 – 8:00 p.m. Thursday only
Friday, December 17, 2010	Classes starting between 7:00 – 7:55 a.m. Wed/Fri or starting between 7:00 – 8:55 a.m. Fri/Sat or Friday only	Classes starting between 10:00 – 10:55 a.m. Wed/Fri or starting between 9:00 – 11:55 a.m. Fri/Sat or Friday only	Classes starting between 11:00 – 11:55 p.m. Wed/Fri or starting between 12:00 – 2:55 p.m. Fri/Sat or Friday only	Classes starting between 1:00 – 2:55 p.m. Fri/Sat, or starting between 3:00 – 4:55 p.m. Fri/Sat or Friday only	Classes starting between 5:00 – 5:55 p.m. Fri/Sat or Friday only	Classes starting between 6:00 – 8:00 p.m. Fri/Sat or Friday only
Saturday, December 18, 2010	Classes starting between 7:00 – 8:55 a.m. Saturday only	Classes starting between 9:00 – 11:55 a.m. Saturday only	Classes starting between 12:00 – 2:55 p.m. Saturday only	Classes starting between 3:00 – 4:55 p.m. Saturday only	Classes starting between 5:00 – 6:55 p.m. Saturday only	No exams scheduled

Please note:

- Each examination is scheduled for two hours. **Final exams for short-term classes shall be administered during the final two hours of the last class period.**
- Every instructor is required to give a final examination following the schedule above. Deviations from the final exam schedule are not permitted because of the potential conflict within students' schedules. If students indicate that a conflict is occurring, instructors are advised to contact their supervising dean immediately.
- Every student is required to take a final examination.
- Final examinations are held in the room in which the class is regularly scheduled.
- Classes that meet Sunday only will have their final exam on Sunday, December 12 at the regularly scheduled time.
- ***In case of a conflict, please consult your instructor.***

SECTION# TIME DAYS INSTRUCTOR LOCATION

ACCOUNTING

Chair: Thelma Day, AD304 (323) 953-4000 ext. 2541
http://www.lacitycollege.edu/academic/departments/busad/index.htm

ACCOUNTING 001 - INTRODUCTORY ACCOUNTING I (UC:CSU) - 5.00 UNITS Rpt 1

PREREQUISITE: 1) Completion or concurrent enrollment in Business 38 or Accounting 31 or appropriate Math course as indicated by student's Math proficiency; 2) Eligibility to enroll in English 101 or completion of 20 units of transfer courses or acceptable work experience; 3) CSIT 103.

Table with 7 columns: Course ID, Section Type, Time, Days, Instructor, Location. Rows include 0100, 0101, 0118, 3001, 3002, and AND sections.

ACCOUNTING 002 - INTRODUCTORY ACCOUNTING II (UC:CSU) - 5.00 UNITS

PREREQUISITE: Accounting 1 or 22 with a satisfactory grade or the equivalent.

Table with 7 columns: Course ID, Section Type, Time, Days, Instructor, Location. Rows include 0102, 0117, 3003, and 3004 sections.

ACCOUNTING 015 - TAX ACCOUNTING I (CSU) - 3.00 UNITS

PREREQUISITE: Accounting 1 or Accounting 22/42 with a satisfactory grade or better or proof of equivalent work completed. (Credit allowed for Accounting 15.)

Table with 7 columns: Course ID, Section Type, Time, Days, Instructor, Location. Row includes 3624 section.

ACCOUNTING 017 - PAYROLL ACCOUNTING - 2.00 UNITS

ADVISORY: English 28 or equivalent. Concerned with procedures and practices involved in a firm's payroll system. Includes familiarizing students with current State and Federal laws with respect to computation of regular and overtime pay, withholding of payroll taxes, computation of employer's payroll taxes, and the preparation of payroll tax returns and reports.

Table with 7 columns: Course ID, Section Type, Time, Days, Instructor, Location. Row includes 3017 section.

ACCOUNTING 021 - BOOKKEEPING AND ACCOUNTING I (UC:CSU) - 3.00 UNITS

PREREQUISITE: 1) Concurrent enrollment in or completion of Accounting 31, Business 38, or Mathematics equivalent and eligibility to enroll in English 28 or 85 or concurrent enrollment in any 3 unit English class indicated by the college placement exam or acceptable work experience. CO-REQUISITE: Accounting 41. (TRANSFER STUDENTS should enroll in Accounting 1.)

Table with 7 columns: Course ID, Section Type, Time, Days, Instructor, Location. Rows include 0104 and 0108 sections.

ACCOUNTING 022 - BOOKKEEPING AND ACCOUNTING II (UC:CSU) - 3.00 UNITS

PREREQUISITE: Accounting 21. CO-REQUISITE: Accounting 42. NOTE: Accounting 22 students must also enroll in Accounting 42 at the same hour and with the same instructor as Accounting 22.

Table with 7 columns: Course ID, Section Type, Time, Days, Instructor, Location. Row includes 0105 section.

ACCOUNTING 027 - AUTOMATED ACCOUNTING METHODS AND PROCEDURES II - 3.00 UNITS

PREREQUISITE: Accounting 1 with a satisfactory grade or better.

DESCRIPTION: Computer applications in the preparation of special journals, payroll register, bank reconciliation, aging accounts receivable, inventory costing and depreciation. Analysis of financial statements and preparation of a computerized practice set.

Table with 7 columns: Course ID, Section Type, Time, Days, Instructor, Location. Row includes 0106 section.

SECTION# TIME DAYS INSTRUCTOR LOCATION

Table with 7 columns: Course ID, Section Type, Time, Days, Instructor, Location. Row includes AND section.

ACCOUNTING 041 - LABORATORY FOR ACCOUNTING 21 - 1.00 UNIT

DESCRIPTION: Accounting 41 students must also enroll in Accounting 21 at the same hour and with the same instructor as Accounting 41. Fundamentals of double-entry accounting; the accounting cycle; preparation of the trial balance; adjusting entries and three basic financial statements; use of controlling accounts; accounting for merchandising and cash transactions; special journals and periodic reporting.

Table with 7 columns: Course ID, Section Type, Time, Days, Instructor, Location. Rows include 0109 and 0115 sections.

ACCOUNTING 042 - LABORATORY FOR ACCOUNTING 22 - 1.00 UNIT

PREREQUISITE: Accounting 41. CO-REQUISITE: Accounting 42 which meets at the same hour.

Table with 7 columns: Course ID, Section Type, Time, Days, Instructor, Location. Row includes 0111 section.

ACCOUNTING 055 - ACCOUNTING COMPUTER LABORATORY - 1.00 UNIT

PREREQUISITE: Accounting 21. Students learn to use the spreadsheet software 'Microsoft Excel' for solving accounting problems and concepts being studied in other accounting class sections.

Table with 7 columns: Course ID, Section Type, Time, Days, Instructor, Location. Row includes 0112 section.

ADMINISTRATION OF JUSTICE

"Also see Corrections"

Chair: Tim Sweetman, HH12 (323) 953-4000 ext. 2753
www.lacitycollege.edu/academic/departments/law/index.html

ADMINISTRATION OF JU 001 - INTRODUCTION TO ADMINISTRATION OF JUSTICE (UC:CSU) - 3.00 UNITS

DESCRIPTION: Philosophy and history of law enforcement, overview of crime and police problems, including police community relations; organization and jurisdiction of local, state, and federal law enforcement agencies, survey of professional career opportunities.

Table with 7 columns: Course ID, Section Type, Time, Days, Instructor, Location. Rows include 0122, 0239, and 3011 sections.

ADMINISTRATION OF JU 002 - CONCEPTS OF CRIMINAL LAW (UC:CSU) - 3.00 UNITS

The students learn the basic principles of the evolution of the English Common Law with emphasis on sections of the California Penal Code most frequently used by police officers.

Table with 7 columns: Course ID, Section Type, Time, Days, Instructor, Location. Rows include 0125 and 3012 sections.

ADMINISTRATION OF JU 003 - LEGAL ASPECTS OF EVIDENCE (CSU) - 3.00 UNITS

DESCRIPTION: Origin, development, philosophy and constitutional basis of evidence; Constitutional consideration of the rules governing the admissibility of evidence in court; and the kinds and degrees of evidence and the judicial rights in a criminal trial.

Table with 7 columns: Course ID, Section Type, Time, Days, Instructor, Location. Row includes 0119 section.

ADMINISTRATION OF JU 004 - PRINCIPLES AND PROCEDURES OF THE JUSTICE SYSTEM (CSU) - 3.00 UNITS

The students cover the legal processes from pre-arrest through trial, sentencing and correctional procedures.

Table with 7 columns: Course ID, Section Type, Time, Days, Instructor, Location. Row includes 1025 section.

SECTION# TIME DAYS INSTRUCTOR LOCATION

ADMINISTRATION OF JU 005 - CRIMINAL INVESTIGATION (CSU) - 3.00 UNITS

This course will cover the fundamentals of a criminal investigation. Topics include: Interviews and interrogations, evidence collection and analysis and case preparation for court.

1113 LEC 12:10 pm - 3:30 pm M SWEETMAN, T N HH 7
3685 LEC 6:50 pm -10:00 pm T SWEETMAN, T N HH 7

ADMINISTRATION OF JU 006 - PATROL PROCEDURES (CSU) - 3.00 UNITS

The students cover the history and development of patrol philosophy; planning for field activities to include functions of patrol, traffic and other preliminary investigative duties of the field officers.

3033 LEC 3:30 pm - 6:40 pm M CONTA, M J HH 204

ADMINISTRATION OF JU 053 - FORENSIC FINGERPRINT EVIDENCE - 3.00 UNITS

Students locate, develop and lift fingerprints from crime scenes. These skills are a must for students interested in law enforcement as a police officer or evidence specialist or for private investigations.

3686 LEC 6:50 pm -10:00 pm W BRAGGS, E J HH 6

ADMINISTRATION OF JU 060 - ARREST, SEARCH AND SEIZURE (CSU) - 3.00 UNITS

Students concentrate on their individual rights as it pertains to an officer searching and/or seizing property. Fourth Amendment rights regarding unreasonable search and seizure are discussed.

0246 LEC 12:10 pm - 3:20 pm Th SWEETMAN, T N HH 7
3323 LEC 3:30 pm - 6:40 pm T SWEETMAN, T N HH 7

ADMINISTRATION OF JU 160 - POLICE ORGANIZATION AND ADMINISTRATION (CSU) - 3.00 UNITS

0243 LEC 10:35 am - 12:00 pm T Th CONTA, M J HH 204

ADMINISTRATION OF JU 180 - INTRODUCTION TO FORENSICS (CSU) - 3.00 UNITS

This course will concentrate on crime scene evidence. Forensic Science and collection techniques will be emphasized as well as the interpreting the evidence.

0244 LEC 12:10 pm - 3:20 pm W SWEETMAN, T N HH 7
3331 LEC 3:30 pm - 6:40 pm M SWEETMAN, T N HH 7

ADMINISTRATION OF JU 391 - FIREARMS: ANALYSIS - 3.00 UNITS

This is a forensic course dealing with firearms and cartridge identification. This class offers a "hands-on" approach through the use of experiments and microscopic comparisons.

3024 LEC 6:50 pm -10:00 pm Th PAUL, D K HH 7

ADMINISTRATION OF JU 396 - TRAFFIC COLLISION INVESTIGATION - 3.00 UNITS

This class will concentrate on investigating traffic collisions by identifying and interpreting forensic evidence as well as diagramming and measuring scenes. Special emphasis will be placed on understanding vehicle and pedestrian dynamics (behavior) associated after a collision.

3049 LEC 6:50 pm -10:00 pm M CORRALES, O HH 7

AFRICAN-AMERICAN STUDIES

Chair: Wendel Eckford, FH219E (323) 953-4000 ext. 2561

<http://www.lacitycollege.edu/citymain/academic.html#SUBJECT/AREA>

AFRICAN AMERICAN STU 004 - THE AFRICAN-AMERICAN IN THE HISTORY OF THE UNITED STATES I (UC:CSU) - 3.00 UNITS

DESCRIPTION: A survey of U.S. history from the early colonial era through the Civil War emphasizing the U.S. Constitution and the contributions of African-Americans. (Same credit as History 11 and Chicano Studies 7.)

0135 LEC 8:00 am - 9:25 am M W EALY, H L FH 221
0136 LEC 9:00 am - 10:25 am T Th ECKFORD, W V FH 221

SECTION# TIME DAYS INSTRUCTOR LOCATION

AFRICAN AMERICAN STU 007 - BLACK AMERICANS AND THE POLITICAL SYSTEM (UC:CSU) - 3.00 UNITS

DESCRIPTION: This course surveys the relationship of minority groups to American politics with emphasis on the African-American in the political system. The course analyzes the distribution of political power and how it affects African Americans.

0212 LEC 10:35 am - 12:00 pm M W EALY, H L FH 220

AFRICAN AMERICAN STU 60 - AFRICAN AMERICAN MUSIC - 3.00 UNITS

DESCRIPTION: A study of African American music and their influences on folk, spirituals, gospels, concert music, opera, ballet, blues, and jazz underscoring styles, characteristics, origin and contributions by African-American artists. (Credit allowed for only one of Music 135 and African-American Studies 60).

5689 LEC 6:50 pm -10:00 pm M HENDERSON L CH 242

AMERICAN SIGN LANGUAGE

Chair: Eiko Chatel, DH312B (323) 953-4000 ext. 2737

<http://www.lacitycollege.edu/citymain/academic.html#SUBJECT/AREA>

AMERICAN SIGN LANGUAGE 001 - AMERICAN SIGN LANGUAGE I (UC:CSU) - 4.00 UNITS

This is an introductory course designed to develop basic conversational skills using the manual alphabet and American Sign Language. It is planned to assist in communicating with deaf individuals and have a better understanding of deaf culture. This course develops basic vocabulary and grammar of American Sign Language. Its emphasis is placed on comprehension skills and vital aspects of the deaf culture and community.

1931 LEC 12:10 pm - 2:15 pm M W QUISPE, A C DH 305
AND LAB - 0:55 hrs TBA STAFF DH 305

AMERICAN SIGN LANGUAGE 002 - AMERICAN SIGN LANGUAGE II (UC:CSU) - 4.00 UNITS

PREREQUISITE: American Sign Language 001. This course completes the study of elementary vocabulary and grammar. Increased development of inflectional and non-manual behavior patterns. Incorporation of selected aspects of Deaf culture and community within receptive and expressive conversation.

3030 LEC 6:50 pm - 8:55 pm M W QUISPE, A C DH 310
AND LAB - 1:05 hrs TBA STAFF DH 319

ANATOMY

Chair: Greg Gonsalves, SCI 222E (323) 953-4000 ext. 2796

<http://www.lacitycollege.edu/academic/departments/lifesci/index.html>

ANATOMY 001 - INTRODUCTION TO HUMAN ANATOMY (UC:CSU) - 4.00 UNITS

ADVISORY: Eligibility in English 28. DESCRIPTION: Students will dissect a laboratory animal comparable in structure to the human body. Students also may purchase instructional dissection materials.*Special tutorial assistance available as they are SI sections.

0140 LEC 9:00 am - 10:25 am M W CENQUIZCA, L A SCI 111
AND LAB 12:10 pm - 3:20 pm W CENQUIZCA, L A SCI 120
0141 LEC 8:00 am - 11:10 am F MIKHAIL, M M SCI 111
AND LAB 12:10 pm - 3:20 pm F MIKHAIL, M M SCI 120
0142 LEC 8:00 am - 11:10 am F MIKHAIL, M M SCI 111
AND LAB 8:00 am - 11:10 am S MIKHAIL, M M SCI 120
3010 LEC 6:50 pm -10:00 pm M WALLANO, E W SCI 126
AND LEC 6:50 pm -10:00 pm F WALLANO, E W SCI 120
5002 LEC 6:50 pm -10:00 pm T STAFF SCI 111
AND LAB 6:50 pm -10:00 pm M STAFF SCI 120
5003 LEC 6:50 pm -10:00 pm T STAFF SCI 111
AND LAB 6:50 pm -10:00 pm W STAFF SCI 120
5006* LEC 3:40 pm - 6:50 pm W KHOLLESI, K SCI 120
AND LAB 3:40 pm - 6:50 pm M KHOLLESI, K SCI 120

Special tutorial assistance available to students in section 5006.

8004 LEC 9:00 am - 10:25 am M W CENQUIZCA, L A SCI 111
AND LAB 12:10 pm - 3:20 pm M CENQUIZCA, L A SCI 120

SECTION#	TIME	DAYS	INSTRUCTOR	LOCATION
8005	LEC 9:00 am - 10:25 am	T Th	CENQUIZCA, L A	SCI 132
AND	LAB 1:45 pm - 4:55 pm	T	CENQUIZCA, L A	SCI 120
8006	LEC 9:00 am - 10:25 am	T Th	CENQUIZCA, L A	SCI 132
AND	LAB 12:10 pm - 3:20 pm	Th	CENQUIZCA, L A	SCI 120

ANTHROPOLOGY

Chair: Wendel Eckford, FH219E (323) 953-4000 ext. 2561

<http://www.lacitycollege.edu/citymain/academic.html#SUBJECT/AREA>

ANTHROPOLOGY 101 - HUMAN BIOLOGICAL EVOLUTION (UC:CSU) - 3.00 UNITS

ADVISORY: English 28. This course examines evolutionary theory, human genetics, classification, an introduction to primates, the hominid fossil record, classification, and modern human variation. Students will be able to underline the historical path to natural selection, describe the five factors of the evolutionary process, identify biological characteristics of primates, discuss features of primate behavior, diagram the origin of mankind through comparing skulls from the hominid fossil record, and interpret modern human variation.

0147	LEC 9:00 am - 10:25 am	M W	BARTELT, B A	FH B22
0148	LEC 7:25 am - 8:50 am	M W	GALLAGHER, E W	FH B22
0220	LEC 10:35 am - 12:00 pm	M W	BARTELT, B A	FH B22
0346	LEC 10:35 am - 12:00 pm	T Th	BARTELT, B A	FH B22

ANTHROPOLOGY 102 - HUMAN WAYS OF LIFE: CULTURAL ANTHROPOLOGY (UC:CSU) - 3.00 UNITS

ADVISORY: English 28 This course establishes the four-field approach to anthropology while covering both anthropological theory and method. Conversations will adopt a holistic perspective to human culture and establish cultural relativism. The objectives of this course are (1) to employ case studies to describe this variation. The student examines communication, learning, subsistence, economics, family, kinship, gender, ethnicity, politics, stratification, globalization, religion, expressive art, and cultural changes as these all affect our lives. Through assigned readings from the text, lectures, discussions and ethnographic investigations, this course will equip you the student with a better understanding of cultural life ways, both past and present, in this time of globalization.

0213	- 3:10 hrs	TBA	BARTELT, B A	ON LINE
0341	LEC 9:00 am - 10:25 am	T Th	BARTELT, B A	FH B22
3045	LEC 6:50 pm - 10:00 pm	W	COHEN, M M	FH B22

ARABIC

Chair: Eiko K. Chatel, DH312B (323) 953-4000 ext. 2737

<http://www.lacitycollege.edu/academic/departments/forlang/index.html>

ARABIC 001 - ELEMENTARY ARABIC I (UC:CSU) - 5.00 UNITS

Advisory: English 28 and 67. DESCRIPTION: Class meets 6 hours; 5 hours lecture and 1 hour TBA in the language lab, DH 319. Pronunciation, grammar, practical vocabulary, useful phrases; basic facts on the geography, customs and culture of the Arabic speaking world.

0154	LEC 10:35 am - 11:45 am	MTWTh	GUIRGUIS, M R	DH 304
AND	LAB - 1:05 hrs	TBA	STAFF	DH 319

ARCHITECTURE AND ENVIRONMENTAL DESIGN

Chair: Gayle Partlow, DH220A (323) 953-4000 ext. 2510

<http://catalog.lacitycollege.edu/pages/architecture.html>

ARCHITECTURE 162 - COMPUTER-AIDED DESIGN AND DRAFTING (CSU) - 3.00 UNITS Rpt 1

DESCRIPTION: Second class in AutoCAD. Advanced drawing and 3D modeling.

3050	LEC 6:50 pm - 7:20 pm	T Th	PUENGPRECHAWAT,	DH 117
AND	LAB 7:20 pm - 9:50 pm	T Th	PUENGPRECHAWAT,	DH 117

ARCHITECTURE 172 - ARCHITECTURAL DRAWING I (CSU) - 3.00 UNITS

Lecture 1 hour; drafting, 5 hours. First level architectural design and technical drawing methodology. Students design a simple one-story residence and prepare a complete set of design and technical drawing of the residence. Fundamental architectural drawing

techniques as well as 3-D computer modeling methods are introduced. The profession of architecture and the practice of architects are clarified. Critical for students applying for work in the architectural or interior design fields as well as students interested in pursuing a higher degree in architecture school or related design field. Great also as a general education course to develop the creative mind and learn to draw architectural plans. Students will also create a portfolio of their work.

5009	LEC 6:50 pm - 7:55 pm	M W	CHIU, W Y	DH 117
AND	LAB 7:55 pm - 10:00 pm	M W	CHIU, W Y	DH 117

ARCHITECTURE 173 - ARCHITECTURAL DRAWING II (CSU) - 3.00 UNITS

PREREQUISITE: Architecture 172 with a satisfactory grade or equivalent. DESCRIPTION: Lecture: 1 hour; Drafting: 5 hours. Second level architectural design and technical drawing methodology. Students design a two-story residence addressing a range of complex contextual and environmental issues, including passive energy design principles. A complete set of design and technical drawings of the residence will be produced. Creative, conceptual and analytical skills are developed. Fundamental architectural drawing techniques as well as 3D computer modeling methods are refined. Critical for students applying for work in the architectural or interior design fields as well as students interested in pursuing a higher degree in architecture school or related design field. Students will also create a portfolio of their work.

5010	LEC 6:50 pm - 7:55 pm	M W	CHIU, W Y	DH 117
AND	LAB 7:55 pm - 10:00 pm	M W	CHIU, W Y	DH 117

ARCHITECTURE 201 - ARCHITECTURAL DESIGN I (UC:CSU) - 3.00 UNITS

DESCRIPTION: Lecture and laboratory: 6 hours. Third level architectural design studio. Students design large and complex projects addressing significantly broader issues both architecturally and contextually. Complex project programmatic requirements are studied and organized in architecturally coherent fashion. Drawing, rendering, computer and model making skills are further refined. Students will examine and analyze the architectural formal and spatial design principles, theories, order and methodologies of significant architects and incorporate them into student projects. Students will also create a portfolio of their work.

8114	LEC 3:30 pm - 4:00 pm	M W	CHIU, W Y	DH 117
AND	LAB 4:00 pm - 6:40 pm	M W	CHIU, W Y	DH 117

ARCHITECTURE 202 - ARCHITECTURAL DESIGN II (UC:CSU) - 3.00 UNITS

PREREQUISITE: Architecture 201 with a satisfactory grade or equivalent. Fourth level architectural design studio. Student imagination, vision and foresight are nurtured through the conception and development of a high density housing community of the near future. Issues of urban fabric, quality of neighborhood, support infrastructure, and transportation will be examined and addressed in the proposed community.

8115	LEC 3:30 pm - 4:00 pm	M W	CHIU, W Y	DH 117
AND	LAB 4:00 pm - 6:40 pm	M W	CHIU, W Y	DH 117

ARCHITECTURE 222 - BEGINNING ARCHITECTURAL GRAPHICS (UC:CSU) - 3.00 UNITS

Lecture and laboratory: 6 hours. Students learn architectural drafting and drawing conventions. Students practice standard techniques to draw plans, elevations, sections, axonometrics, and perspectives as well as non-traditional methods. A variety of media are explored and utilized to create a range of graphic outcome. The course also covers

3841	LEC 3:30 pm - 4:15 pm	T Th	CHIU, W Y	DH 117
AND	LAB 4:15 pm - 6:40 pm	T Th	CHIU, W Y	DH 117

ARCHITECTURE 271 - ARCHITECTURAL DRAWING III (CSU) - 3.00 UNITS

Prerequisite: Architecture 173. Third level architectural design and technical drawing methodology. Students design a multiple story residence on a down slope site addressing a range of complex contextual and environmental issues, including passive energy design principles. Different building materials such as concrete and metal will be studied and incorporated into the building. A complete set of design and technical drawings of the residence will be produced.

5011	LEC 6:50 pm - 7:55 pm	M W	CHIU, W Y	DH 117
AND	LAB 7:55 pm - 10:00 pm	M W	CHIU, W Y	DH 117

SECTION#	TIME	DAYS	INSTRUCTOR	LOCATION
----------	------	------	------------	----------

ARCHITECTURE 272 - ARCHITECTURAL DRAWING IV (CSU) - 3.00 UNITS

PREREQUISITE: Architecture 271. Fourth level architectural design and technical drawing methodology. Students design a multi-story mid density residence which will address a range of complex contextual and environmental issues, passive energy design principles and code compliance design. Different building materials such as concrete and metal will be studied and incorporated into the building. A complete set of design and technical drawings of the residence will be produced. Creative, conceptual and analytical skills are further developed. Fundamental architectural drawing techniques as well as 3-d computer modeling methods are refined. Students will create a portfolio of their work.

5012	LEC	6:50 pm - 7:55 pm	M W	CHIU, W Y	DH 117
AND	LAB	7:55 pm -10:00 pm	M W	CHIU, W Y	DH 117

ENVIRONMENTAL DESIGN

ENVIRONMENTAL DESIGN 101 - FOUNDATIONS OF DESIGN I (CSU) - 3.00 UNITS

First level architectural design studio. Students develop creative, conceptual and analytical skills by creating simple to complex projects. Learn to properly communicate architectural concepts through drawings, renderings, physical models, and computer 3-d modeling. Fundamental architectural formal and spatial design principles, theories, order and methodologies are explored and incorporated into student projects. The profession of architecture and the practice of architects are clarified. Critical for students interested in pursuing a higher degree in architecture school or related design field. Recommended for all art and interior design related fields. Great also as a general education course to develop the creative mind. Students will also create a portfolio of their work.

8116	LEC	3:30 pm - 4:00 pm	M W	CHIU, W Y	DH 117
AND	LAB	4:00 pm - 6:40 pm	M W	CHIU, W Y	DH 117

ENVIRONMENTAL DESIGN 102 - FOUNDATIONS OF DESIGN II (CSU) - 3.00 UNITS

Prerequisite: Environmental Design 101. Second level architectural design studio. Students continue to develop creative, conceptual and analytical skills by designing more complex projects addressing multiple programmatic requirements, symbolism and contextualism. Drawing, rendering, computer and model making skills are further refined. Students will also create a portfolio of their work

8117	LEC	3:30 pm - 4:00 pm	M W	CHIU, W Y	DH 117
AND	LAB	4:00 pm - 6:40 pm	M W	CHIU, W Y	DH 117

ARMENIAN

Chair: Eiko K. Chatel, DH312B (323) 953-4000 ext. 2737
<http://www.lacitycollege.edu/academic/departments/forlang/index.html>

ARMENIAN 001 - ELEMENTARY ARMENIAN I (UC:CSU) - 5.00 UNITS

ADVISORY: English 28 and 67 or equivalent. The student completes the fundamentals of pronunciation and elementary grammar, practical vocabulary and useful phrases to understand, read and write simple Armenian.

3057	LEC	6:50 pm - 9:20 pm	M W	KESHISHIAN, O K	DH 307
AND	LAB	- 1:05 hrs	TBA	STAFF	DH 319

ART

Chair: Gayle Partlow, DH220A (323) 953-4000 ext. 2510
<http://catalog.lacitycollege.edu/pages/art.html>

ART 101 - SURVEY OF ART HISTORY I (UC:CSU) - 3.00 UNITS

ADVISORY: English 28 or equivalent. DESCRIPTION: The development of art from the Prehistoric period to the time of the Renaissance emphasizing the cultural context of the West, and its major points of contact with the Non-European world.

0169	LEC	9:00 am - 10:25 am	T Th	LOPEZ, E C	HH 6
3060	LEC	6:50 pm -10:00 pm	M	BLACKWELL, P A	HH 6

SECTION#	TIME	DAYS	INSTRUCTOR	LOCATION
----------	------	------	------------	----------

ART 102 - SURVEY OF ART HISTORY II (UC:CSU) - 3.00 UNITS

ADVISORY: English 28 and 67 or equivalent. Students learn about the development of Art from the time of the Renaissance to the Early 20th Century. Emphasis is placed on the cultural context of the West while major points of artistic contact with the Non-European world is considered.

0167	LEC	10:35 am - 12:00 pm	M W	SCHWAB, N W	HH 6
3062	LEC	6:50 pm -10:00 pm	Th	SCHWAB, N W	HH 6

ART 103 - ART APPRECIATION I (UC:CSU) - 3.00 UNITS

ADVISORY: English 28 or equivalent. DESCRIPTION: An introductory lecture course. A broad exploration of art forms and media in traditional and contemporary art styles. Museum and gallery visits are part of the course requirements.

0228	LEC	10:35 am - 12:00 pm	T Th	STAFF	HH 6
3234	LEC	6:50 pm -10:00 pm	W	STAFF	HH 6

ART 105 - HISTORY OF ASIAN ART (UC:CSU) - 3.00 UNITS

ADVISORY: English 28 or equivalent. DESCRIPTION: A survey of the chronological development of the arts of India, China, Japan, and adjacent areas with emphasis upon cultural factors which contributed to their evolution.

3235	LEC	6:50 pm -10:00 pm	T	O'LEARY, T F	HH 6
------	-----	-------------------	---	--------------	------

ART 185 - DIRECTED STUDY - ART HONORS (CSU - 1.00 UNITS Rpt 2)

PREREQUISITE: 30 units, at least a "C" average and third semester status in Art at LACC, with all courses in the student's discipline having been passed.

8026		-1:05 hrs	TBA	PARTLOW, G M	DH 220
------	--	-----------	-----	--------------	--------

ART 201 - DRAWING I (UC:CSU) - 3.00 UNITS

NOTE: ART 201 & 501 ARE PREREQUISITES FOR MANY ART COURSES AND MEET THE GENERAL HUMANITIES REQUIREMENTS FOR GRADUATION PLAN B. DESCRIPTION: Various drawing approaches are explored in several black and white media with emphasis upon the development of observation and skills in graphic representation.

0171	LEC	1:00 pm - 3:10 pm	S	WARNER, C	DH 109
AND	LAB	3:10 pm - 5:20 pm	S	WARNER, C	DH 109
0172	LEC	9:45 am - 10:50 am	M W	BROWN, G R	DH 109
AND	LAB	10:50 am - 11:55 am	M W	BROWN, G R	DH 109
0173	LEC	9:45 am - 10:50 am	T Th	KO, K S	DH 109
AND	LAB	10:50 am - 11:55 am	T Th	KO, K S	DH 109
0175	LEC	12:10 pm - 1:15 pm	M W	STAFF	DH 109
AND	LAB	1:15 pm - 2:20 pm	M W	STAFF	DH 109
0236	LEC	7:25 am - 8:30 am	M W	STAFF	DH 109
AND	LAB	8:30 am - 9:35 am	M W	STAFF	DH 109
0238	LEC	12:10 pm - 1:15 pm	T Th	STAFF	DH 109
AND	LAB	1:15 pm - 2:20 pm	T Th	STAFF	DH 109
3063	LEC	5:15 pm - 7:20 pm	T	STEINBERG, C L	DH 109
AND	LAB	7:20 pm - 9:25 pm	T	STEINBERG, C L	DH 109

ART 202 - DRAWING II (UC:CSU) - 3.00 UNITS

PREREQUISITE: Art 201 and 501 with a satisfactory grade or equivalent. DESCRIPTION: A continuation of Drawing I with emphasis on observation and skill together with an awareness of the expressive and compositional aspects of drawing with color.

0165	LEC	1:00 pm - 2:05 pm	M W	STAFF	DH 218
AND	LAB	2:05 pm - 3:10 pm	M W	STAFF	DH 218

ART 204 - LIFE DRAWING I (UC:CSU) - 3.00 UNITS

PREREQUISITE: Art 201 with a satisfactory grade or equivalent and Art 501. CO-REQUISITE: Art 501 may be taken concurrently. DESCRIPTION: Drawing from the live model in various media, solving problems related to structure, anatomy, composition and design.

8022	LEC	9:45 am - 10:50 am	T Th	PALEY, L H	DH 218
AND	LAB	10:50 am - 11:55 am	T Th	PALEY, L H	DH 218
8037	LEC	12:10 pm - 1:15 pm	T Th	ADSIT, R V	DH 218
AND	LAB	1:15 pm - 2:20 pm	T Th	ADSIT, R V	DH 218

SECTION#	TIME	DAYS	INSTRUCTOR	LOCATION
----------	------	------	------------	----------

ART 205 - LIFE DRAWING II (UC:CSU) - 3.00 UNITS

PREREQUISITE: Art 204 with a satisfactory grade or equivalent. DESCRIPTION: Drawing and painting from the live model in various media.

8024	LEC	9:45 am - 10:50 am	T Th	PALEY, L H	DH 218
AND	LAB	10:50 am - 11:55 am	T Th	PALEY, L H	DH 218
8027	LEC	12:10 pm - 1:15 pm	T Th	ADSIT, R V	DH 218
AND	LAB	1:15 pm - 2:20 pm	T Th	ADSIT, R V	DH 218

ART 206 - LIFE DRAWING III (UC:CSU) - 3.00 UNITS

PREREQUISITE: Art 205 with a satisfactory grade or equivalent.

8028	LEC	9:45 am - 10:50 am	T Th	PALEY, L H	DH 218
AND	LAB	10:50 am - 11:55 am	T Th	PALEY, L H	DH 218
8039	LEC	12:10 pm - 1:15 pm	T Th	ADSIT, R V	DH 218
AND	LAB	1:15 pm - 2:20 pm	T Th	ADSIT, R V	DH 218

ART 207 - LIFE DRAWING IV (UC:CSU) - 3.00 UNITS

PREREQUISITE: Art 206 with a satisfactory grade or equivalent.

8029	LEC	9:45 am - 10:50 am	T Th	PALEY, L H	DH 218
AND	LAB	10:50 am - 11:55 am	T Th	PALEY, L H	DH 218
8040	LEC	12:10 pm - 1:15 pm	T Th	ADSIT, R V	DH 218
AND	LAB	1:15 pm - 2:20 pm	T Th	ADSIT, R V	DH 218

ART 209 - PERSPECTIVE DRAWING I (UC:CSU) - 3.00 UNITS

DESCRIPTION: Learning to draw three-dimensional objects in space using measured vanishing point systems along with direct observation and free hand drawing. Explores methods of drawing cast shadows and mirror reflections in perspective.

0176	LEC	9:45 am - 11:50 am	F	RIPPLE, R G	DH 117
AND	LAB	11:50 am - 1:55 pm	F	RIPPLE, R G	DH 117

ART 285 - DIRECTED STUDY - ART HONORS (CSU) - 2.00 UNITS

PREREQUISITE: 30 units, at least a "C" average and third semester status in Art at LACC, with all courses in the student's discipline having been passed.

8030	-	2:05 hrsTBAPARTLOW, G M		DH 220	
------	---	-------------------------	--	--------	--

ART 300 - INTRODUCTION TO PAINTING (UC:CSU) - 3.00 UNITS

PREREQUISITE: Art 201 with a satisfactory grade or equivalent. CO-REQUISITE: Art 501. DESCRIPTION: Introduction to the technique of watercolor painting applied to still life, landscape, and the human figure.

8032	LEC	9:45 am - 10:40 am	M W	PARTLOW, G M	DH 119
AND	LAB	10:50 am - 11:55 am	M W	PARTLOW, G M	DH 119

ART 301 - WATERCOLOR PAINTING I (UC:CSU) - 3.00 UNITS

PREREQUISITE: Art 300 with a satisfactory grade or equivalent.

8034	LEC	9:45 am - 10:40 am	M W	PARTLOW, G M	DH 119
AND	LAB	10:50 am - 11:55 am	M W	PARTLOW, G M	DH 119

ART 302 - WATERCOLOR PAINTING II (UC:CSU) - 3.00 UNITS

PREREQUISITE: Art 301 with a satisfactory grade or equivalent. DESCRIPTION: Continuation of techniques and concepts. Exploration of abstract styles.

8036	LEC	9:45 am - 10:40 am	M W	PARTLOW, G M	DH 119
AND	LAB	10:50 am - 11:55 am	M W	PARTLOW, G M	DH 119

ART 303 - WATERCOLOR PAINTING III (UC:CSU) - 3.00 UNITS

PREREQUISITE: Art 302. DESCRIPTION: Greater emphasis on individual interpretation and conceptual use of the watercolor medium.

8038	LEC	9:45 am - 10:40 am	M W	PARTLOW, G M	DH 119
AND	LAB	10:50 am - 11:55 am	M W	PARTLOW, G M	DH 119

ART 304 - ACRYLIC PAINTING I (UC:CSU) - 3.00 UNITS

PREREQUISITE: Art 201 and 501 with a satisfactory grade or equivalent. DESCRIPTION: Introduction to a variety of techniques employing acrylic paints and related grounds and materials.

8031	LEC	1:00 pm - 3:05 pm	T Th	SCHWAB, N W	DH 119
------	-----	-------------------	------	-------------	--------

SECTION#	TIME	DAYS	INSTRUCTOR	LOCATION
----------	------	------	------------	----------

ART 305 - ACRYLIC PAINTING II (UC:CSU) - 3.00 UNITS

PREREQUISITE: Art 304 with a satisfactory grade or equivalent. DESCRIPTION: Continuation of technical and media explorations with the development and creative use of painting and drawing aesthetic concepts.

8033	LEC	1:00 pm - 3:05 pm	T Th	SCHWAB, N W	DH 119
------	-----	-------------------	------	-------------	--------

ART 306 - ACRYLIC PAINTING III (UC:CSU) - 3.00 UNITS

PREREQUISITE: Art 305 with a satisfactory grade or equivalent. DESCRIPTION: The expanded exploration of concepts and subject matter with emphasis on personal and independent interpretation.

8035	LEC	1:00 pm - 3:05 pm	T Th	SCHWAB, N W	DH 119
------	-----	-------------------	------	-------------	--------

ART 307 - OIL PAINTING I (UC:CSU) - 3.00 UNITS

PREREQUISITE: Art 201 and 501 with a satisfactory grade or equivalent. Students develop skills in handling the oil painting medium. Students work from the study of still life, landscape, and the live model.

8053	LEC	1:00 pm - 1:30 pm	M W	PALEY, L H	DH 119
AND	LAB	1:30 pm - 4:10 pm	M W	PALEY, L H	DH 119

ART 308 - OIL PAINTING II (UC:CSU) - 3.00 UNITS

PREREQUISITE: Art 307 with a satisfactory grade or equivalent. Students explore the oil painting medium in a variety of perceptual problems. Students work from the study of still life, landscape, and the live model.

8054	LEC	1:00 pm - 1:30 pm	M W	PALEY, L H	DH 119
AND	LAB	1:30 pm - 4:10 pm	M W	PALEY, L H	DH 119

ART 309 - OIL PAINTING III (UC:CSU) - 3.00 UNITS

PREREQUISITE: Art 308 with a satisfactory grade or equivalent. Students explore the oil painting medium in a variety of perceptual problems. Students work toward individual growth and development of personal concepts.

8055	LEC	1:00 pm - 1:30 pm	M W	PALEY, L H	DH 119
AND	LAB	1:30 pm - 4:10 pm	M W	PALEY, L H	DH 119

ART 385 - DIRECTED STUDY - ART HONORS (CSU) - 3.00 UNITS

PREREQUISITE: 30 units, at least a "C" average and third semester status in Art at LACC, with all courses in the student's discipline having been passed.

8042	-	3:10 hrsTBAPARTLOW, G M		DH 220	
------	---	-------------------------	--	--------	--

ART 400 - INTRODUCTION TO PRINTMAKING (UC:CSU) - 3.00 UNITS

PREREQUISITE: Art 201, and Art 501, with satisfactory grades or equivalent. DESCRIPTION: A laboratory course introducing students to various forms of plate-making and printing. Emphasis placed on visual ideas.

8019	LEC	9:45 am - 10:15 am	T Th	SCHWAB, N W	DH 115
AND	LAB	10:20 am - 12:50 pm	T Th	SCHWAB, N W	DH 115

ART 401 - ETCHING I (UC:CSU) - 3.00 UNITS

PREREQUISITE: Art 400 with a satisfactory grade or equivalent. DESCRIPTION: An intermediate course which concentrates on etching as a form of intaglio printing. Contemporary techniques including photo-etching will be introduced.

8020	LEC	9:45 am - 10:15 am	T Th	SCHWAB, N W	DH 115
AND	LAB	10:20 am - 12:50 pm	T Th	SCHWAB, N W	DH 115

ART 402 - ETCHING II (UC:CSU) - 3.00 UNITS

PREREQUISITE: Art 401 with a satisfactory grade or equivalent. DESCRIPTION: Further development of skills and the proficient application of printmaking techniques.

8021	LEC	9:45 am - 10:15 am	T Th	SCHWAB, N W	DH 115
AND	LAB	10:20 am - 12:50 pm	T Th	SCHWAB, N W	DH 115

SECTION# TIME DAYS INSTRUCTOR LOCATION

ART 407 - RELIEF PRINTMAKING I (UC:CSU) - 3.00 UNITS

PREREQUISITE: Art 402 with a satisfactory grade or equivalent. DESCRIPTION: Explores relief and planographic processes. Work in relief etching, multiple plates, and monotypes with emphasis on color.

8023 LEC 9:45 am - 10:15 am T Th SCHWAB, N W DH 115
AND LAB 10:20 am - 12:50 pm T Th SCHWAB, N W DH 115

ART 408 - RELIEF PRINTMAKING II (UC:CSU) - 3.00 UNITS

PREREQUISITE: Art 407 with a satisfactory grade or equivalent. DESCRIPTION: Advanced printmaking stressing contemporary techniques. Printmaking as creative expression in today's fine art field.

8025 LEC 9:45 am - 10:15 am T Th SCHWAB, N W DH 115
AND LAB 10:20 am - 12:50 pm T Th SCHWAB, N W DH 115

ART 501 - BEGINNING TWO-DIMENSIONAL DESIGN (UC:CSU) - 3.00 UNITS

NOTE: ART 501& 201 ARE PREREQUISITES FOR MANY ART COURSES AND MEET THE GENERAL HUMANITIES REQUIREMENT FOR GRADUATION PLAN B. DESCRIPTION: A foundation studio course focused on creative visual thinking and expression. Establishes working methods and concepts of composition used in all other art classes. Basic art elements like line, shape, value, and color are emphasized. Studies the role of graphic communication in society.

0180 LEC 7:25 am - 8:30 am T Th STAFF DH 113
AND LAB 8:30 am - 9:35 am T Th STAFF DH 113
0182 LEC 12:10 pm - 1:15 pm M W LOSCHUK, V L DH 113
AND LAB 1:15 pm - 2:20 pm M W LOSCHUK, V L DH 113
0184 LEC 8:00 am - 10:10 am S NOWLIN, O B DH 113
AND LAB 10:10 am - 12:20 pm S NOWLIN, O B DH 113
0249 LEC 9:45 am - 10:50 am T Th STAFF DH 113
AND LAB 10:50 am - 11:55 am T Th STAFF DH 113
3064 LEC 5:15 pm - 7:20 pm W GREENFIELD, M S DH 113
AND LAB 7:20 pm - 9:25 pm W GREENFIELD, M S DH 113

ART 503 - INTERMEDIATE DESIGN (UC:CSU) - 3.00 UNITS

PREREQUISITE: Art 501 with a satisfactory grade or equivalent. DESCRIPTION: Form, texture, and especially color applied to creative projects aimed at concept development. Design factors applied to new art media, including video.

0187 LEC 9:45am - 10:40 am M W PALEY, L H DH 113
AND LAB 10:50 am - 11:55 am M W PALEY, L H DH 113

ART 604 - GRAPHIC DESIGN I (CSU) - 3.00 UNITS

PREREQUISITE: Art 501 and Art 633 with a satisfactory grade. DESCRIPTION: Introductory graphic design course -- the field, its terminology, tools and working methods. Emphasis is placed on basic hands-on and computer layout skills and their application to creative visual communication, with a strong emphasis on typographical, technical and historical elements.

0185 LAB 9:45 am - 10:40 am M W CAUFIELD, P J DH 219
AND LEC 10:50 am - 11:55 am M W CAUFIELD, P J DH 219

ART 606 - GRAPHIC DESIGN III (CSU) - 3.00 UNITS

PREREQUISITE: Art 605 and 639 with a satisfactory grade. DESCRIPTION: Applied graphic design using computer graphics. Emphasis is placed on creation of illustrations and digital images and their integration into page layout software to produce press-ready graphics.

0343 LEC 9:45 am - 10:50 am T Th CAUFIELD, P J DH 219
AND LAB 10:50 am - 11:55 am T Th CAUFIELD, P J DH 219

ART 620 - ILLUSTRATION I (CSU) - 3.00 UNITS

PREREQUISITE: Art 201 with a satisfactory grade or equivalent. CO-REQUISITE: Art 501. DESCRIPTION: Drawing, rendering and composition skills are extended to problems in commercial illustration - pictorial art for publications and advertising. Variety of media and techniques.

0186 LEC 9:45 am - 10:50 am T Th PARTLOW, G M DH 117
AND LAB 10:50 am - 11:55 am T Th PARTLOW, G M DH 117

SECTION# TIME DAYS INSTRUCTOR LOCATION

ART 633 - INTRODUCTION TO COMPUTER GRAPHICS (CSU) - 3.00 UNITS

PREREQUISITE: Art 501 with a satisfactory grade. DESCRIPTION: Introductory course in computer graphics using primarily Adobe Illustrator. The Macintosh operating system, color modes, file formats, basic scanning and printing techniques as well as web research will also be surveyed.

0190 LAB 7:25 am - 8:25 am M W CAUFIELD, P J DH 219
AND LEC 8:40 am - 9:35 am M W CAUFIELD, P J DH 219

ART 634 - COMPUTER GRAPHICS I: 3D COMPUTER GRAPHICS (CSU) - 3.00 UNITS

PREREQUISITE: Art 633 with a satisfactory grade or equivalent. (NOTE: Students must also enroll in Art 638, Computer Graphics Lab.) DESCRIPTIONS: Exploration of three-dimensional digital design techniques, concepts, and applications employed as tools in graphic design. The course focuses on three-dimensional modeling and rendering techniques in the creation of objects and environments for graphics and multimedia.

0194 LEC 1:00 pm - 2:05 pm M W PARTLOW, G M DH 219
AND LAB 2:05 pm - 3:10 pm M W PARTLOW, G M DH 219

ART 639 - INTRODUCTION TO DIGITAL IMAGING (CSU) - 3.00 UNITS

PREREQUISITE: Art 501 and 633. DESCRIPTION: Introductory course in computer imaging still image manipulation using Adobe Photoshop.

1065 LEC 7:25 am - 8:25 am T Th CAUFIELD, P J DH 219
AND LAB 8:30 am - 9:35 am T Th CAUFIELD, P J DH 219

ART 708 - INTRODUCTION TO CERAMICS (UC:CSU) - 3.00 UNITS

PREREQUISITE: Art 501 with a satisfactory grade or equivalent. DESCRIPTIONS: A beginning course which involves learning basic methods of pottery making. Effective use of design factors unique to clay is stressed. Demonstration-lectures augment this laboratory course.

5032 LEC 6:00 pm - 6:30 pm M W STAFF DH 6
AND LAB 6:30 pm - 9:00 pm M W STAFF DH 6

ART 709 - CERAMICS I (UC:CSU) - 3.00 UNITS

PREREQUISITE: Art 708 with a satisfactory grade or equivalent. DESCRIPTION: Development of technical and design skills on the potter's wheel and in making ceramic molds.

5033 LEC 6:00 pm - 6:30 pm M W STAFF DH 6
AND LAB 6:30 pm - 9:00 pm M W STAFF DH 6

ART 710 - CERAMICS II (UC:CSU) - 3.00 UNITS

PREREQUISITE: Art 709 with a satisfactory grade or equivalent. DESCRIPTION: Continued development of mechanical skills with added studies in the preparation of ceramic glazes and bodies.

5034 LEC 6:00 pm - 6:30 pm M W STAFF DH 6
AND LAB 6:30 pm - 9:00 pm M W STAFF DH 6

ART 711 - CERAMICS III (UC:CSU) - 3.00 UNITS

PREREQUISITE: Art 710 with a satisfactory grade or equivalent. DESCRIPTION: The design and development of projects of special interest to the advanced student focused on either industrial design or clay as a fine art medium.

5035 LEC 6:00 pm - 6:30 pm M W STAFF DH 6
AND LAB 6:30 pm - 9:00 pm M W STAFF DH 6

ASTRONOMY

Chair: Jayesh Bhakta, SCI222D (323) 953-4000 ext 2923
<http://catalog.lacitycollege.edu/academic/departments/physics/>

ASTRONOMY 001 - ELEMENTARY ASTRONOMY (UC:CSU) - 3.00 UNITS

ADVISORY: English 28 or concurrent enrollment in Learning Skills 1 or 7. A fascinating look into the general principles and the fundamentals facts of astronomy. This introductory courses is designed for the non-technical student. Topics covered include the history and science of astronomy, the solar system, our sun, stars, galaxies and

SECTION#	TIME	DAYS	INSTRUCTOR	LOCATION
cosmology. No college math preparation is needed. If a student wishes to transfer this as a lab science course, the student must also complete Astronomy 5.				
0221	LEC	12:10 pm - 1:35 pm	M W	MCCUDDEN, P J SCI 111
3071	LEC	6:50 pm -10:00 pm	Th	MILLER, C O SCI 111
3072	LEC	3:30 pm - 6:40 pm	W	GOODMAN, T M SCI 111
3074	LEC	6:50 pm -10:00 pm	M	EAGLE, R J SCI 111
5471	LEC	10:35 am - 12:00 pm	T Th	MCCUDDEN, P J SCI 111

ASTRONOMY 005 - FUNDAMENTALS OF ASTRONOMY LABORATORY (UC:CSU) - 1.00 UNITS

Advisory: Astronomy 1. A presentation of the methods and techniques used by astronomers to determine the nature of the universe. This course involves working with and learning the operation of Astronomical instruments and equipments including the 12 inch telescope housed in the Los Angeles City College Observatory.

3077	LAB	3:30 pm - 6:40 pm	M	GOODMAN, T M SCI 200
3079	LAB	6:50 pm -10:00 pm	W	AKOPIAN, V SCI 200
3080	LAB	6:50 pm -10:00 pm	T	ARVIDSON, D SCI 204

ASTRONOMY 011 - STARS, GALAXIES, AND THE UNIVERSE (UC:CSU) - 3.00 UNITS

This conceptual course surveys the universe beyond the solar system. Students learn about stars, stellar evolution, black holes, galaxies, the big bang, cosmology and the possibility of extraterrestrial life.

1773	LEC	1:45 pm - 3:15 pm	T Th	ARVIDSON, D SCI 111
------	-----	-------------------	------	---------------------

BIOLOGY

Chair: Greg Gonsalves, SCI 222E (323) 953-4000 ext. 2796

<http://www.lacitycollege.edu/academic/departments/lifesci/index.html>

BIOLOGY 003 - INTRODUCTION TO BIOLOGY (UC:CSU) - 4.00 UNITS

ADVISORY: English 21. DESCRIPTION: This course meets the general laboratory science requirement. *Special tutorial assistance available as they are SI sections.

0230	LEC	10:35 am - 12:00 pm	M W	GARCIA, M J SCI 103
AND	LAB	12:10 pm - 3:20 pm	M	GARCIA, M J SCI 104
*0231	LEC	8:00 am - 11:10 am	T	GARCIA, M J SCI 111
Special tutorial assistance available to students in section 0231.				
AND	LAB	8:00 am - 11:10 am	Th	GARCIA, M J SCI 104
0233	LEC	8:00 am - 11:10 am	S	SHAHBAZIAN, F M SCI 103
AND	LAB	12:10 pm - 3:20 pm	S	SHAHBAZIAN, F M SCI 104
0234	LEC	8:00 am - 11:10 am	T	GARCIA, M J SCI 111
AND	LAB	12:10 pm - 3:20 pm	Th	GARCIA, M J SCI 104
0235	LEC	9:00 am - 10:25 am	M W	GARCIA, M J SCI 103
AND	LAB	12:10 pm - 3:20 pm	W	GARCIA, M J SCI 104
5281	LEC	6:50 pm -10:00 pm	T	PHOMMASAYS, S SCI 132
AND	LAB	6:50 pm -10:00 pm	Th	PHOMMASAYS, S SCI 106

BIOLOGY 006 - GENERAL BIOLOGY I (UC:CSU) - 5.00 UNITS

PREREQUISITE: Chemistry 60 and Mathematics 125. ADVISORY: Eligibility in English 28 or its equivalent. DESCRIPTION: For general biology majors and pre-professional students.

8066	LEC	12:10 pm - 1:35 pm	M W	PHOMMASAYS, S SCI 130
AND	LAB	8:00 am - 11:10 am	T Th	PHOMMASAYS, S SCI 106
8067	LEC	12:10 pm - 1:35 pm	M W	PHOMMASAYS, S SCI 130
AND	LAB	1:45 pm - 4:55 pm	T Th	PHOMMASAYS, S SCI 106
8466	LEC	12:10 pm - 1:35 pm	M W	PHOMMASAYS, S SCI 130
AND	LAB	8:00 am - 11:10 am	T Th	PHOMMASAYS, S SCI 106
8467	LEC	12:10 pm - 1:35 pm	M W	PHOMMASAYS, S SCI 130
AND	LAB	1:45 pm - 4:55 pm	T Th	PHOMMASAYS, S SCI 106

BIOLOGY 025 - HUMAN BIOLOGY (UC:CSU) - 3.00 UNITS

ADVISORY: Eligibility for English 28. DESCRIPTION: A survey course for the non-science major. The principle human organ systems are studied according to structure and function.

3083	LEC	6:50 pm -10:00 pm	T	ARAI, V E SCI 130
-------------	------------	--------------------------	----------	--------------------------

SECTION#	TIME	DAYS	INSTRUCTOR	LOCATION
----------	------	------	------------	----------

BUSINESS

Chair: Thelma Day, AD304 (323) 953-4000 ext. 2541

<http://www.lacitycollege.edu/academic/departments/busad/index.html>

BUSINESS 001 - INTRODUCTION TO BUSINESS (UC:CSU) - 3.00 UNITS

ADVISORY: English 28 or equivalent. DESCRIPTION: A survey of business including forms of business organization, finance, personnel problems, marketing, managerial aids, business government relations; and business.

0240	LEC	12:10 pm - 1:35 pm	M W	EGEREGOR, A E AD 301A
0241	LEC	10:35 am - 12:00 pm	M W	EGEREGOR, A E AD 301A
3086	LEC	6:50 pm -10:00 pm	W	BROWN, C H AD 301A
3091	LEC	6:50 pm -10:00 pm	Th	OKPARA, N G AD 301A
3542	LEC	6:50 pm -10:00 pm	M	CHING, B AD 303

BUSINESS 015 - BUSINESS STATISTICS (UC:CSU) - 3.00 UNITS

PREREQUISITE: Mathematics 125 - see instructor. ADVISORY: Collection, tabulation and presentation of data; averages and index numbers, economic trends and cycles, correlation, and the application of these methods to the solution of practical business problems.

0245	LEC	7:25 am - 8:50 am	T Th	STEVENS, E L AD 301A
3087	LEC	3:30 pm - 6:40 pm	M	GUYNES, L C AD 306

BUSINESS 017 - COMPUTER GRAPHICS FOR BUSINESS - 3.00 UNITS

PREREQUISITE: Business 1. DESCRIPTION: A comprehensive course in business graphics covering types of business graphics, their uses and techniques for generating graphics emphasizing computer usage, techniques and current computer graphics software.

0247	LEC	12:10 pm - 2:15 pm	M	HASTEY, R B AD 316
AND	LAB	2:15 pm - 4:25 pm	M	HASTEY, R B AD 316
3088	LEC	5:15 pm - 7:20 pm	T	HASTEY, R B AD 316
AND	LAB	7:20 pm - 9:25 pm	T	HASTEY, R B AD 316

BUSINESS 038 - BUSINESS COMPUTATIONS (CSU) - 3.00 UNITS

ADVISORY: English 28 or equivalent. DESCRIPTION: Credit allowed for only one of Business 38 or Accounting 31. Problems in ordinary business situations and on civil service examinations. Arithmetic fundamentals, including addition, subtraction, multiplication and division of whole numbers and fractions are reviewed. Practical problems include interest, cash and trade discount, mark up and mark- down, payrolls, and percentage.

0250	LEC	9:00 am - 10:25 am	M W	SCHENCK, L R AD 309
3089	LEC	6:50 pm -10:00 pm	M	RICE, H D AD 301A

BUSINESS 911 - COOPERATIVE EDUCATION - BUSINESS (CSU) - 1.00 UNITS Rpt 3

9016	-	1:05 hrs	TBA	WERBLE, D M AD 209
------	---	----------	-----	--------------------

BUSINESS 921 - COOPERATIVE EDUCATION - BUSINESS (CSU) - 2.00 UNITS Rpt 3

9017	-	2:05 hrs	TBA	WERBLE, D M AD 209
------	---	----------	-----	--------------------

BUSINESS 931 - COOPERATIVE EDUCATION - BUSINESS (CSU) - 3.00 UNITS Rpt 3

9018	-	3:10 hrs	TBA	WERBLE, D M AD 209
------	---	----------	-----	--------------------

BUSINESS 941 - COOPERATIVE EDUCATION - BUSINESS (CSU) - 4.00 UNITS Rpt 3

9019	-	4:15 hrs	TBA	WERBLE, D M AD 209
------	---	----------	-----	--------------------

SECTION# TIME DAYS INSTRUCTOR LOCATION

CHEMISTRY

Chair: John Freitas, SCI 324B (323) 953-4000 ext 2600
<http://www.lacitycollege.edu/academic/departments/chemistry/>

CHEMISTRY 060 - INTRODUCTION TO GENERAL CHEMISTRY (UC:CSU) - 5.00 UNITS

PREREQUISITE: Math 115 or Placement Exam . ADVISORY: English 28 and 67 or English 31 This course prepares students for Chemistry 101 and satisfies the chemistry requirement for the LACC Nursing Program. It covers atomic structure, nomenclature, bonding, molecular geometry, chemical reactions, stoichiometry, states of matter and related forces, gas laws, solution chemistry, quantum theory, periodic properties, colligative properties, and acid base concepts. This course satisfies the IGETC and CSU general education requirements for physical science with laboratory. *Special tutorial assistance available as they are SI sections.

0251	LEC	10:35 am - 12:00 pm	M W	BOAN, T A	SCI 132
AND	LAB	8:20 am - 10:25 am	M W	LANDBERG, B E	SCI 305
0252	LEC	10:35 am - 12:00 pm	M W	BOAN, T A	SCI 132
AND	LAB	12:10 pm - 2:15 pm	M W	BOAN, T A	SCI 305
0254*	LEC	10:35 am - 12:00 pm	M W	BOAN, T A	SCI 132
AND	LAB	12:10 pm - 2:15 pm	M W	LANDBERG, B E	SCI 301
Special tutorial assistance available to students in section 0254.					
0253	LEC	7:25 am - 8:50 am	T Th	LANDBERG, B E	SCI 132
AND	LEC	9:00 am - 11:05 am	T Th	LANDBERG, B E	SCI 301
0255	LEC	7:25 am - 8:50 am	T Th	LANDBERG, B E	SCI 132
AND	LAB	9:00 am - 11:05 am	T Th	HYMOWITZ, V V	SCI 305
5036	LEC	5:15 pm - 6:40 pm	T Th	SHIN, P K	SCI 132
AND	LAB	6:55 pm - 9:00 pm	T Th	SHIN, P K	SCI 301
5037	LEC	5:15 pm - 6:40 pm	T Th	SHIN, P K	SCI 132
AND	LAB	6:55 pm - 9:00 pm	T Th	LANDBERG, B E	SCI 305
5040	LEC	5:15 pm - 6:40 pm	T Th	SHIN, P K	SCI 132
AND	LAB	2:50 pm - 4:55 pm	T Th	BOAN, T A	SCI 305
5044	LEC	6:50 pm - 10:00 pm	F	CASTRO, P	SCI 132
AND	LAB	7:50 am - 12:00 pm	S	CASTRO, P	SCI 305
5045	LEC	6:50 pm - 10:00 pm	F	CASTRO, P	SCI 132
AND	LAB	7:50 am - 12:05 pm	S	MAYS, P J	SCI 301

IMPORTANT INFORMATION FOR STUDENTS ENROLLING IN CHEM 101

1. Students who have not completed Chemistry 60 or 68, or the approved equivalent course, must earn a satisfactory score on the Chemistry Readiness Exam which is administered by the LACC Assessment Office. For more information about the exam and when it is administered contact the Matriculation Office at (323)953-4000, ext. 2264. You may also refer to the following website for information about the exam: <http://www.lacitycollege.edu/services/matriculation/assessment.html>

All exam appointments must be scheduled in person in AD103.

2. Challenges to prerequisites must be made through the Counseling Center in AD108. Transcripts are required. For more information contact the Counseling Center at (323)953-4000, ext. 2250. **The Chemistry Readiness Exam applies only to the chemistry course prerequisite. Passing the Chemistry Readiness Exam does not waive the Math 125 prerequisite.**

CHEMISTRY 101 - GENERAL CHEMISTRY I (UC:CSU) - 5.00 UNITS

PREREQUISITE: Chemistry 60 or Chemistry 68, or ACS California Diagnostic Exam and Mathematics 125 with a satisfactory grade better. ADVISORY: English 28 and 67. This class is required for science and engineering majors. It covers atomic structure, nomenclature, bonding, molecular geometry, chemical reactions, stoichiometry, thermochemistry, states of matter and related forces, gas laws, solution chemistry, quantum theory, periodic properties, colligative properties, and acid base concepts.

1343	LEC	9:00 am - 10:25 am	M W	FREITAS, J E	SCI 314
AND	CONF	9:00 am - 10:00 am	T Th	FREITAS, J E	SCI 314
AND	LAB	10:00 am - 12:05 pm	T Th	FREITAS, J E	SCI 306
1344	LEC	10:35 am - 12:00 pm	M W	BAGHDASARIAN, G	SCI 314
AND	CONF	12:10 pm - 1:10 pm	M W	BAGHDASARIAN, G	SCI 314
AND	LAB	1:10 pm - 3:15 pm	M W	GIFFORD, M E	SCI 306
5038	LEC	5:15 pm - 6:40 pm	M W	TORRES, O J	SCI 314

SECTION# TIME DAYS INSTRUCTOR LOCATION

AND	CONF	6:50 pm - 7:50 pm	M W	TORRES, O J	SCI 314
AND	LAB	7:55 pm - 10:00 pm	M W	TORRES, O J	SCI 306

CHEMISTRY 102 - GENERAL CHEMISTRY II (UC:CSU) - 5.00 UNITS

PREREQUISITE: Chemistry 101 with a satisfactory grade or better; Mathematics 125. ADVISORY: English 28 and 67. Thermodynamics, kinetics and equilibrium, electrochemistry, nuclear, organic, transition metal chemistry, and qualitative analysis.

0260	LEC	1:45 pm - 3:10 pm	M W	CARTER, E F	SCI 314
AND	CONF	1:45 pm - 2:45 pm	T Th	CARTER, E F	SCI 314
AND	LAB	2:55 pm - 5:00 pm	T Th	CARTER, E F	SCI 306
3095	LEC	5:15 pm - 6:40 pm	T Th	BOAN, T A	SCI 314
AND	CONF	6:50 pm - 7:50 pm	T Th	BOAN, T A	SCI 314
AND	LAB	7:55 pm - 10:00 pm	T Th	BOAN, T A	SCI 306

CHEMISTRY 211 - ORGANIC CHEMISTRY FOR SCIENCE MAJORS I (UC:CSU) - 5.00 UNITS

PREREQUISITE: Chemistry 102 with a satisfactory grade or better. ADVISORY: English 28 and 67. Structure, nomenclature, synthesis and mechanisms in organic chemistry; synthesis and isolation, spectroscopy, and chromatography.

8071	LEC	9:00 am - 10:25 am	M W	CARTER, E F	SCI 301
AND	CONF	9:00 am - 10:00 am	T Th	CARTER, E F	SCI 304
AND	LAB	10:00 am - 12:05 pm	T Th	CARTER, E F	SCI 304

CHEMISTRY 212 - ORGANIC CHEMISTRY FOR SCIENCE MAJORS II (UC:CSU) - 5.00 UNITS

PREREQUISITE: Chemistry 211 with satisfactory grade or better. ADVISORY: English 28 and 67. Emphasis on specific functional groups, carbohydrates and proteins, and advanced synthesis spectroscopy and qualitative analysis.

3096	LEC	5:15 pm - 6:40 pm	T Th	BAGHDASARIAN, G	SCI 301
AND	CONF	6:50 pm - 7:50 pm	T Th	BAGHDASARIAN, G	SCI 304
AND	LAB	7:55 pm - 10:00 pm	T Th	BAGHDASARIAN, G	SCI 304

CHICANO STUDIES

Chair: Wendel Eckford, FH211E (323) 953-4000 ext. 2561
<http://www.lacitycollege.edu/citymain/academic.html#SUBJECT/AREA>

CHICANO STUDIES 007 - THE MEXICAN-AMERICAN IN THE HISTORY OF THE UNITED STATES I (UC:CSU) - 3.00 UNITS

DESCRIPTION: A survey of U.S. history from the colonial era through the Civil War emphasizing contributions of the Mexican-American and the U.S. Constitution. (Same credit as History 11 and African-American Studies 4).

0264		- 3:10 hrs	TBA	GUERRERO, C R	ON LINE
3100	LEC	3:30 pm - 6:40 pm	M	GUERRERO, C R	FH 218
(This course is taught partially online. Students need an internet account.)					

CHICANO STUDIES 008 - THE MEXICAN-AMERICAN IN THE HISTORY OF THE UNITED STATES II (UC:CSU) - 3.00 UNITS

DESCRIPTION: A survey of U.S. history from the end of the Civil War to the present with emphasis on the Mexican-American's social, economic, and political development. Covers the U.S. Constitution. (Same credit as History 12 and African-American Studies 5).

0214		- 3:10 hrs	TBA	GUERRERO, C R	ON LINE
0266	LEC	9:00 am - 10:25 am	M W	GUERRERO, C R	FH 220

CHICANO STUDIES 044 - MEXICAN CIVILIZATION (UC:CSU) - 3.00 UNITS

DESCRIPTION: Covers Pre-Colombian Indians of Mexico; Spanish conquest and domination, and Mexico during colonial era; the Revolution of independence against Spain; the Revolution of 1910, and contemporary Mexico. (Fulfills Humanities requirements for graduation).

0267	LEC	10:35 am - 12:00 pm	M W	GUERRERO, C R	FH 218
3102		- 3:10 hrs	TBA	GUERRERO, C R	ON LINE

CHILD DEVELOPMENT

Chair: Kathleen Bimber, CDB202 (323) 953-4000 ext 2295

<http://www.lacitycollege.edu/academic/departments/childdev/index.html>

CHILD DEVELOPMENT 001 - CHILD GROWTH AND DEVELOPMENT (UC:CSU) - 3.00 UNITS

CO-REQUISITES: English 21 or 73, or higher, and English 67. ADVISORY: Learning Skills 3E Vocabulary (1 unit). An introductory Child Development course that examines the major physical, psychosocial, and cognitive/language developmental milestones for children, both typical and atypical, from conception through adolescence. There is an emphasis on interactions between maturational processes and environmental factors. While studying developmental theory and investigative research methodologies, students will observe children, evaluate individual differences and analyze characteristics of development at various stages.

0270	LEC	-3:10 hrs	TBA	MILLER, K M	ON LINE
0271	LEC	9:00 am - 12:10 pm	F	WASHBURN, N E	CD 215
0272	LEC	9:00 am - 12:10 pm	M	STAFF	CD 215
0273	LEC	9:00 am - 12:10 pm	S	STAFF	CD 215
3106	LEC	3:30 pm - 6:40 pm	M	WERBLE, C L	CD 215
Special tutorial assistance available to students in section 3106.					
3107	LEC	6:50 pm -10:00 pm	T	CHUA, C	CD 215

CHILD DEVELOPMENT 002 - EARLY CHILDHOOD: PRINCIPLES AND PRACTICES (CSU) - 3.00 UNITS

CO-REQUISITE: English 28 and 31 and 67 or equivalent; and Child Development 1. Verification of Mantoux test (or chest X-Ray) is required. A survey course which compares and analyzes historical as well as current models of early childhood programs. Students examine the underlying theoretical principles of developmentally appropriate practices applied to programs and environments. Emphasis is placed on the key role of relationships, constructive adult-child interactions and teaching strategies that support physical, social, creative and intellectual development of children and lead to desired learning outcomes. Professional development and career paths based upon CA Child Developmental Permit Matrix will be discussed.

0269	LEC	9:00 am - 12:10 pm	Th	WERBLE, C L	CD 210
3108	LEC	3:30 pm - 6:40 pm	Th	WASHBURN, N E	CD 210
3109	LEC	6:50 pm -10:00 pm	W	RUIZ, EC	CD 220

CHILD DEVELOPMENT 003 - CREATIVE EXPERIENCES FOR CHILDREN I (CSU) - 3.00 UNITS

PREREQUISITE: Child Development 1 and 2 with a satisfactory grade, and English 28 or 31 or equivalent with satisfactory grade. DESCRIPTION: Students develop and implement creative curriculum for young children. Activities include: sensorimotor, manipulative, art, music, movement, and dramatic play experiences. Emphasis is on environments that promote creativity and the role of the teacher. Enrollment recommended in CD84 or 85: Child Development Labs, one hour TBA a week to develop activities and lessons.

0268	LEC	9:00 am - 12:10 pm	Th	MILLER, K M	CD 220
3110	LEC	6:50 pm -10:00 pm	M	LOWE, F D	CD 220

CHILD DEVELOPMENT 007 - INTRODUCTION TO CURRICULUM IN EARLY CHILDHOOD EDUCATION (CSU) - 3.00 UNITS

0114	LEC	9:00 am - 12:20 pm	S	GARCIA OLIVA, C E	CD 220
3103	LEC	3:30 pm - 6:40 pm	Th	SKOUSEN RADFORD	CD 220

CHILD DEVELOPMENT 010 - HEALTH, SAFETY AND NUTRITION (CSU) - 3.00 UNITS

CO-REQUISITE: English 21 or 73 or equivalent. DESCRIPTION: Study of the interrelationship of health, safety and nutrition and the impact on children's growth and development. Students learn how to implement a comprehensive nutritional program, use universal precautions and implement emergency procedures.

0277	LEC	9:00 am - 12:10 pm	T	SKOUSEN RADFORD	CD 220
3112	LEC	6:50 pm -10:00 pm	Th	STAFF	CD 220

CHILD DEVELOPMENT 011 - HOME, SCHOOL, AND COMMUNITY RELATIONS (CSU) - 3.00 UNITS

CO-REQUISITE: English 21 and 67 or equivalent. Students examine the developing child in a societal context focusing on the interrelationship of the family, school and community and emphasizes historical and socio-cultural factors. The processes of socialization and identity development will be highlighted, showing the importance of respectful, reciprocal relationships that support and empower families. Some topics covered are: social influences on parenting styles, communication, child-rearing and the relationships between the child, family and the school is studied.

0280	LEC	9:00 am - 12:10 pm	Th	WASHBURN, N E	CD 210
0281	LEC	3:30 pm - 6:40 pm	W	WASHBURN, N E	CD 215
3113	LEC	6:50 pm -10:00 pm	Th	STAFF	CD 215

CHILD DEVELOPMENT 022 - PRACTICUM IN CHILD DEVELOPMENT I (CSU) - 4.00 UNITS

PREREQUISITE: Child Development 3 and 4. NOTES: Students must show proof of a current negative TB test (Mantoux Test) or chest x-ray within the last two years. The Department of Social Services Child Care Licensing Division and the Department of Health require all individuals working with children in a paid or voluntary position to have a negative Mantoux test or chest x-ray every two years. (Title 22 101216). Students are assigned to an approved Child Development program to demonstrate developmentally appropriate early childhood teaching competencies under guided supervision. Students utilize practical classroom experiences to make connections between theory and practice, develop professional behaviors, and build a comprehensive understanding of children and families. Child centered, play-oriented approaches to teaching, learning, assessment and knowledge of curriculum content areas is emphasized as student teachers design, implement and evaluate experiences that promote positive development and learning.

3641	LEC	6:50 pm - 8:55 pm	T	SKOUSEN RADFORD	CD 214
AND	LAB	- 6:30 hrs	TBA	SKOUSEN RADFORD	FIEL D
3642	LEC	4:00 pm - 6:05 pm	W	MILLER, K M	CD 220
AND	LAB	- 6:30 hrs	TBA	MILLER, K M	FIEL D

CHILD DEVELOPMENT 023 - PRACTICUM IN CHILD DEVELOPMENT II (CSU) - 4.00 UNITS

PREREQUISITE: Child Development 22 with a satisfactory grade. DESCRIPTION: State law requires a TB test (Mantoux Test) or chest x-ray. Please bring proof of your TB clearance to the first class. NOTE: In addition to the seminar class, students are required to complete a minimum of 90 hours TBA at an APPROVED field site. To be eligible for field placement, students MUST be available two days a week, either from 8:00am - 12:00 Noon OR 12:00 Noon - 4:00pm on MW, or TTh, or WF. Priority field placement will be given to students who meet this schedule.

3645	LEC	4:30 pm - 6:20 pm	T	WERBLE, C L	CD 215
AND	LAB	- 6:30 hrs	TBA	WERBLE, C L	FIEL D

CHILD DEVELOPMENT 030 - INFANT AND TODDLER STUDIES I (CSU) - 3.00 UNITS

Co-requisite: English 21 or 73 or equivalent. Verification of Mantoux test (TB test) or chest x-ray is required. DESCRIPTION: A study of infant/toddler development from birth through toddlerhood. The birth process, attachment, temperament and development as well as responsive parenting/care-giving and culturally sensitive environments that support development will be covered.

3114	LEC	3:30 pm - 6:40 pm	T	WASHBURN, N E	CD 220
------	-----	-------------------	---	---------------	--------

CHILD DEVELOPMENT 034 - OBSERVING AND RECORDING CHILDREN'S BEHAVIOR (CSU) - 3.00 UNITS

Prerequisite: Child Development 1 or equivalent and English 28 and 67. Verification of annual Mantoux test or chest x-ray is required. Students learn the appropriate use of assessment and observation strategies to document development, growth, play and learning to join with families and professionals in promoting children's success. Recording strategies, rating systems, portfolios, and multiple assessment tools are explored.

3115	LEC	3:30 pm - 6:40 pm	M	MILLER, K M	CD 220
------	-----	-------------------	---	-------------	--------

SECTION# TIME DAYS INSTRUCTOR LOCATION

CHILD DEVELOPMENT 038 - ADMINISTRATION & SUPERVISION OF EARLY CHILDHOOD PROGRAMS I (CSU) - 3.00 UNITS

DESCRIPTION: This course prepares students to establish and administer an early childhood program. Financial aspects of administration are emphasized. This course partially fulfills the licensing requirements for the director.

3105 LEC 6:50 pm -10:00 pm M COLEMAN, M I CD 215

CHILD DEVELOPMENT 044 - PROGRAMS FOR CHILDREN WITH SPECIAL NEEDS I (CSU) - 3.00 UNITS

ADVISORY: English 21 This course is designed for students intending to work with children with special needs. Students examine components of a comprehensive service delivery system that is based on legal mandates and an understanding of typical development across all domains. Also discussed is the role of observation and documentation in adapting the environment, creating instructional strategies an in developing Individual Education Plans.

3118 LEC 6:50 pm -10:00 pm T SBURLAN, A F CD 210

CHILD DEVELOPMENT 048 - POSITIVE GUIDANCE IN EARLY CHILDHOOD SETTINGS (CSU) - 3.00 UNITS

PREREQUISITE: Child Development 2 and English 28 or 31 or equivalent. DESCRIPTION: This class emphasizes developmentally appropriate guidance techniques for children in early childhood settings. Students will learn how to develop individualized plans for positive guidance of young children.

3647 LEC 6:50 pm -10:00 pm W WASHBURN, N E CD 215

CHILD DEVELOPMENT 084 - CHILD DEVELOPMENT LAB I - 0.50 UNITS Rpt 3

ADVISORY: Child Development 2 or 3 or 4 or 10 or 22/23 or 30/31 or 35 or 42 or 44/45 or 46/47. Students interested, or currently working in the field of Child Development, or taking Child Development classes, may use lab materials, curriculum resource books, technology and equipment to design lesson plans, games, and other curricular activities. A \$20 lab fee is required.

0282 LAB - 1:05 hrs TBA SKOUSEN RADFORD TBA TBA
0283 LEC - 1:05 hrs TBA SKOUSEN RADFORD TBA TBA

CHILD DEVELOPMENT 085 - CHILD DEVELOPMENT LAB II - 0.50 UNITS Rpt 3

DESCRIPTION: Students interested in continuing the Child Development Lab experience will focus on quality literacy experiences such as, exposure to age-appropriate literacy materials (modeling or practicing) library habits under the supervision of a literacy expert. Students will evaluate and analyze literacy materials, able to write activity plans, and create instructional materials that support emerging literacy. A \$20.00 lab fee is required.

0278 LEC - 1:05 hrs TBA WERBLE, C L TBA TBA

CHINESE

Chair: Eiko K. Chatel, DH312B (323) 953-4000 ext. 2737
<http://www.lacitycollege.edu/academic/departments/forlang/index.html>

CHINESE 001 - ELEMENTARY CHINESE I (UC:CSU) - 5.00 UNITS

ADVISORY: English 28 and 67. Mandarin Chinese corresponds the first year of high school Chinese. Pronunciation, grammar, practical vocabulary, and basic facts on the geography, customs and culture of China.

0286 LEC 9:00 am - 10:10 am MTWTh LIAO, R M DH 308
AND LAB - 1:05 hrs TBA STAFF DH 319
3051 LEC 6:50 pm - 9:20 pm T Th LIAO, R M DH 308
AND LAB - 1:00 hrs TBA STAFF DH 319

CHINESE 002 - ELEMENTARY CHINESE II (UC:CSU) - 5.00 UNITS

PREREQUISITE: Chinese 1 Completes the elementary Mandarin Chinese grammar, introduces reading and writing of elementary texts.

0120 LEC 10:35 am - 11:50 am MTWTh LIAO, R M DH 308
AND LAB - 0:55 hrs TBA STAFF DH 319
3026 LEC 6:50 pm - 9:25 pm M W LIU, H H DH 308
AND LAB - 0:55 hrs TBA STAFF DH 319

SECTION# TIME DAYS INSTRUCTOR LOCATION

CHINESE 010 - CHINESE CIVILIZATION (UC:CSU) - 3.00 UNITS

ADVISORY: English 28 This course offers the students lectures and discussions in English on history, culture, geography, government and institutions of China, the life style and customs of the people, the language. literature, arts, and sciences, the contributions to civilization.

0287 LEC 12:10 pm - 1:35 pm M W LIAO, R M DH 308

CINEMA - (See Television)

Chair: Vaughn Obern, CC181 (323) 953-4000 ext. 2627
<http://cinematv.lacitycollege.edu/obervng@lacitycollege.edu>

CINEMA 001 - INTRODUCTION TO MOTION PICTURE PRODUCTION (UC:CSU) - 3.00 UNITS

DESCRIPTION: Open to all students. (Required of all Cinema Majors.) A comprehensive introduction to film video production techniques and equipment. NOTE: Students will be dropped or may not enroll if not present at the first class session.

0291 LEC 9:00 am - 11:05 am M VARNER, J K CC 176
AND LAB 11:05 am - 1:15 pm M VARNER, J K CC 176
3127 LEC 6:00 pm - 8:05 pm M VARNER, J K CC 176
AND LAB 8:05 pm -10:15 pm M VARNER, J K CC 176

CINEMA 002 - BEGINNING MOTION PICTURE WORKSHOP (UC:CSU) - 3.00 UNITS

Introductory workshop in practical filmmaking. Each student will be responsible for making several short films in digital video. Cinema 1 may be taken concurrently. NOTE: Students will be dropped or may not enroll if not present at the first class session.

0290 LEC 9:55 am - 10:50 am Th KUNTZ, J A CC 228
AND LAB 10:50 am - 3:15 pm Th KUNTZ, J A CC 228
0292 LEC 9:55 am - 10:50 am Th OBERN, V G CC 176
AND LAB 10:50 am - 3:15 pm Th OBERN, V G CC 176
3128 LEC 5:15 pm - 7:45 pm Th KUNTZ, J A CC 228
AND LAB 7:45 pm -10:35 pm Th KUNTZ, J A CC 228
3129 LEC 5:15 pm - 7:45 pm Th OBERN, V G CC 176
AND LAB 7:45 pm -10:35 pm Th OBERN, V G CC 176

CINEMA 003 - HISTORY OF MOTION PICTURES (UC:CSU) - 3.00 UNITS

DESCRIPTION: Required of all first-semester Cinema Majors. Open to all others. History of the development of motion pictures, with examples, from their beginnings to the present day. Emphasis is placed on the American feature film. NOTE: Students will be dropped or may not enroll if not present at the first class session.

0293 LEC 12:10 pm - 2:15 pm T KUNTZ, J A CC 176
AND LAB 2:15 pm - 4:25 pm T KUNTZ, J A CC 176
0299 LEC 9:00 am - 11:05 am S STAFF CC 176
AND LAB 11:05 am - 1:15 pm S STAFF CC 176
3130 LEC 6:00 pm - 8:05 pm T KUNTZ, J A CC 176
AND LAB 8:05 pm -10:15 pm T KUNTZ, J A CC 176

CINEMA 004 - HISTORY OF THE DOCUMENTARY FILM (UC:CSU) - 3.00 UNITS

DESCRIPTION: Required of all first-semester Cinema Majors. Open to all others. The historical development of films dealing with the truth. NOTE: Students will be dropped or may not enroll if not present at the first class session.

0294 LEC 12:10 pm - 2:15 pm W STEMPEL, T R CC 176
AND LAB 2:15 pm - 4:25 pm W STEMPEL, T R CC 176
3131 LEC 6:00 pm - 8:05 pm W STEMPEL, T R CC 176
AND LAB 8:05 pm -10:15 pm W STEMPEL, T R CC 176

CINEMA 005 - INTRODUCTION TO SCREENWRITING (CSU) - 3.00 UNITS Rpt 1

PREREQUISITE: Cinema 1, 2, 3, and 4 with satisfactory grades or better. Students develop and write screenplays. Cinema majors write scripts for films they will make in

SECTION#	TIME	DAYS	INSTRUCTOR	LOCATION
Cinema 15 or 33. NOTE: Students will be dropped or may not enroll if not present at the first class session.				
0295	LEC	12:10 pm - 2:15 pm	Th	STEMPEL, T R CC 149
AND	LAB	2:15 pm - 4:25 pm	Th	STEMPEL, T R CC 149
3123	LEC	6:00 pm - 8:05 pm	Th	DOMOKOS, C A CC 149
AND	LAB	8:05 pm -10:15 pm	Th	DOMOKOS, C A CC 149

CINEMA 006 - MOTION PICTURE PHOTOGRAPHY (CSU) - 3.00 UNITS

PREREQUISITE: Cinema 1, 2, 3, 4. This course is an introduction to cinematography, including optics, photo emulsions, camera operation, laboratory procedures, terminology and aesthetics. Students complete individual and group projects using 16mm or digital video camera equipment. NOTE: Students will be dropped or may not enroll if not present at the first class session.

0296	LEC	7:45 am - 8:50 am	M	STAFF CC 143
AND	LAB	8:50 am -12:00 pm	M	STAFF CC 143
3132	LEC	6:00 pm - 8:05 pm	T	STAFF CC 143
AND	LAB	8:05 pm -10:15 pm	T	STAFF CC 143

CINEMA 007 - ADVANCED CINEMATOGRAPHY AND CREATIVE TECHNIQUES (CSU) - 3.00 UNITS

PREREQUISITE: Cinema 6 with a satisfactory grade or better. DESCRIPTION: An advanced course in creative cinematography covering sophisticated professional equipment and techniques used in the motion picture industry. Emphasis is placed on lighting and current industry standards. NOTE: Students will be dropped or may not enroll if not present at the first class session. NOTE: Students will be dropped or may not enroll if not present at the first class session.

3000	LEC	5:45 pm - 8:05 pm	Th	HAINE, C M CC 143
AND	LAB	8:05 pm -10:25 pm	Th	HAINE, C M CC 143

CINEMA 009 - MOTION PICTURE SOUND - 3.00 UNITS

PREREQUISITE: Cinema 1, 2, 3 and 4 with satisfactory grades or better. DESCRIPTION: Students learn the basics of motion picture production and post-production sound. Students use digital audio recorders, microphones and booms and learn how to properly record sound. Students learn to loop and mix sounds using a digital audio program. NOTE: Students will be dropped or may not enroll if not present at the first class session.

1345	LEC	9:00 am - 10:05 am	S	ANDERSON, A A CC 149
AND	LAB	10:05 am - 2:20 pm	S	ANDERSON, A A CC 149

CINEMA 010 - INTRODUCTION TO FILM DIRECTING (CSU) - 3.00 UNITS Rpt 1

Prerequisite: Cinema 1, 2, 3, and 4 with satisfactory grades or better. The student is introduced to the crafts of acting and directing for the film medium. NOTE: Students will be dropped or may not enroll if not present at the first class session.

1346	LEC	12:10 pm - 2:15 pm	W	COOK, B R CC 143
AND	LAB	2:15 pm - 4:25 pm	W	COOK, B R CC 143
3138	LEC	6:00 pm - 8:05 pm	Th	DESMARAIS, J J CC 125
AND	LEC	8:05 pm -10:10 pm	Th	DESMARAIS, J J CC 125

CINEMA 020 - BUSINESS ASPECTS OF MOTION PICTURE PRODUCTION (CSU) - 3.00 UNITS

PREREQUISITE: Cinema 1, 2, 3, and 4 with satisfactory grades or better. DESCRIPTION: Survey of business practices including financing, production and distribution. NOTE: Students will be dropped or may not enroll if not present at the first class session.

3136	LEC	6:50 pm -10:00 pm	W	COOK, B R CC 228
-------------	------------	--------------------------	----------	-------------------------

CINEMA 032 - EDITING FUNDAMENTALS - 3.00 UNITS

PREREQUISITE: Cinema 1, 2, 3 and 4 with satisfactory grades or better. DESCRIPTION: Lecture: 1 hour. Laboratory: 4 hours. Intermediate students will learn the basics of editing with non-linear digital equipment. NOTE: Students will be dropped or may not enroll if not present at the first class session.

1350	LEC	9:55 am - 10:55 am	W	JONES, D L CC 228
AND	LAB	10:55 am - 3:10 pm	W	JONES, D L CC 228

SECTION#	TIME	DAYS	INSTRUCTOR	LOCATION
3135	LEC	5:15 pm - 6:15 pm	M	JONES, D L CC 228
AND	LAB	6:15 pm -10:35 pm	M	JONES, D L CC 228

CINEMA 033 - DIGITAL VIDEO PRODUCTION WORKSHOP I - 3.00 UNITS Rpt 1

PREREQUISITE: Cinema 1, 2, 3 and 4 with satisfactory grades or better. DESCRIPTION: Intermediate film and television students will produce short video projects using basic digital video cameras and editing systems. (Same as Television 55). NOTE: Students will be dropped or may not enroll if not present at the first class session.

5053	LEC	5:15 pm - 6:15 pm	T	VARNER, J K CC 118
AND	LAB	6:15 pm -10:35 pm	T	VARNER, J K CC 118
8097	LEC	12:10 pm - 1:10 pm	Th	VARNER, J K CC 118
AND	LAB	1:10 pm - 5:30 pm	Th	VARNER, J K CC 118

CINEMA 034 - MOTION PICTURES SOUNDSTAGE PRODUCTION PRACTICUM - 3.00 UNITS Rpt 1

PREREQUISITE: Cinema 5 or 6 or 7 or 9 or 10 or 35 or 32. DESCRIPTION: Designed for students to gain practical experience in a specific area of motion picture soundstage production in order to develop the necessary skills needed in that field of the industry. Included skills are screenwriting, directing, production management, lighting, cinematography, sound recording and editing. NOTE: Students will be dropped or may not enroll if not present at the first class session. NOTE: Students will be dropped or may not enroll if not present at the first class session.

0301	LEC	12:10 pm - 1:10 pm	T	STAFF CC 143
AND	LAB	1:10 pm - 5:30 pm	T	STAFF CC 143

CINEMA 038 - MOTION PICTURE STAGE GRIP - 3.00 UNITS Rpt 1

In this hands-on course, students learn basic grip skills and operate grip equipment and tools used in motion picture stages, television studios, and on location during film and television production including, but not limited to, a Grip Cart, C-Stands, Apple Boxes, Scaffolding, Manlifts, Gels, Ropes, Plates, Clamps, Wedges, Cribbing, Cucolori, Flags and Scrims, Gaffer Tape, Griffion, Gaffer Grips, and Mole-a-gators. . Topics covered include stage safety, operating procedures, set etiquette, basic tool usage, basic grip equipment usage, and basic lighting safety and lighting fixture usage. Students have the option to learn the safety and basic use of power tools in the construction of an Apple Box as an individual project. NOTE: Students will be dropped or may not enroll if not present at the first class session.

0300	LEC	1:45 pm - 3:50 pm	M	MENDEZ, R J CC 125
AND	LAB	3:50 pm - 5:45 pm	M	MENDEZ, R J CC 125

CINEMA 185 - DIRECTED STUDY - CINEMA (CSU) - 1.00 UNITS Rpt 2

PREREQUISITE: Cinema 5 with satisfactory grades or better. (Graded as credit/no-credit). DESCRIPTION: Designed to allow the advanced LACC Cinema student to work independently in screenwriting or post-production. (Enrollment by ADD CARD ONLY, the first day of class.

8051	LEC	9:00 am - 9:55 am	W	OBERN, V G CC 260
------	-----	-------------------	---	-------------------

CINEMA 911 - COOPERATIVE EDUCATION - CINEMA (CSU) - 1.00 UNITS Rpt 3

9028	-	1:05 hrs	TBA	STAFF AD 209
------	---	----------	-----	--------------

CINEMA 921 - COOPERATIVE EDUCATION - CINEMA (CSU) - 2.00 UNITS Rpt 3

9029	-	2:05 hrs	TBA	STAFF AD 209
------	---	----------	-----	--------------

CINEMA 931 - COOPERATIVE EDUCATION - CINEMA (CSU) - 3.00 UNITS Rpt 3

9030	-	3:10 hrs	TBA	STAFF AD 209
------	---	----------	-----	--------------

CINEMA 941 - COOPERATIVE EDUCATION - CINEMA (CSU) - 4.00 UNITS Rpt 3

9031	-	4:15 hrs	TBA	WERBLE, D M AD 209
------	---	----------	-----	--------------------

SECTION# TIME DAYS INSTRUCTOR LOCATION

COMPUTER APPLICATIONS OFFICE TECHNOLOGIES (CAOT)

Chair: Thelma Day, AD304 (323) 953-4000 ext. 2541 http://caot.lacitycollege.edu/

COMPUTER APPLICATIONS OFFICE TECHNOLOGIES 001 - COMPUTER KEYBOARDING I (CSU) - 3.00 UNITS

ADVISORY: Assessment Exam eligibility for ESL Level 6. DESCRIPTION: Mastery of the keyboard by touch (letters, tables, reports, and memos) using Microsoft Word.

Table with columns: Section#, Time, Days, Instructor, Location. Rows include 1006 LEC 9:00 am - 11:05 am F MORIMOTO, C S DH 204, 1008 LEC 7:25 am - 8:10 am MTWTh BELL, B DH 204, 1009 LEC 9:00 am - 11:05 am S STAATS, A A DH 204, 1012 LEC 12:10 pm - 1:10 pm M W ROSARIO, G D DH 303, 1013 LEC - 2:05 hrs TBA MORIMOTO, C S ON LINE morimocs@lacitycollege.edu, 3465 LEC 6:50 pm - 7:55 pm M W SCOTT, J D DH 204, AND LAB 7:55 pm - 9:20 pm M W SCOTT, J D DH 204

COMPUTER APPLICATIONS OFFICE TECHNOLOGIES 002 - COMPUTER KEYBOARDING II (CSU) - 3.00 UNITS

PREREQUISITE: Ability to type 30 words a minute. ADVISORY: Eligibility for ESL Level 6B and 6C, or completion of CAOT 1 or CAOT 1C with satisfactory grade or better. Students should enroll in CAOT 9 or CAOT 1 if they do not meet the requirements for CAOT 2. DESCRIPTION: Speed and accuracy development and document production using a computer and Microsoft Word or WordPerfect.

Table with columns: Section#, Time, Days, Instructor, Location. Rows include 1015 LEC 7:25 am - 7:55 am MTWTh SAMBRANO, R DH 202, 8383 LEC 9:00 am - 11:05 am S HO, A DH 202, AND LAB 11:05 am - 2:15 pm S HO, A DH 202

COMPUTER APPLICATIONS OFFICE TECHNOLOGIES 003 - COMPUTER KEYBOARDING III (CSU) - 3.00 UNITS

PREREQUISITE: CAOT 2 and CAOT 84 Develops production skills in using advanced features of Microsoft Word to create properly formatted business documents. Includes composition at keyboard, decision making, and timed production of letters, tables, and reports. Develops minimum speed at end of course of 50wpm.

Table with columns: Section#, Time, Days, Instructor, Location. Rows include 8384 LEC 9:00 am - 11:05 am S HO, A DH 202, AND LAB 11:05 am - 2:15 pm S HO, A DH 202

COMPUTER APPLICATIONS OFFICE TECHNOLOGIES 009 - COMPUTER KEYBOARDING IMPROVEMENT (CSU) - 1.00 UNITS Rpt 2

PREREQUISITE: CAOT 1. The student improves keyboarding procedures through continued emphasis on correct keyboarding techniques and develops speed and accuracy through timed writings and corrective drills.

Table with columns: Section#, Time, Days, Instructor, Location. Row: 0316 LAB 10:35 am - 12:00 pm T Th BELL, B DH 203

COMPUTER APPLICATIONS OFFICE TECHNOLOGIES 020 - MEDICAL OFFICE PROCEDURES (CSU) - 5.00 UNITS

PREREQUISITE: CAOT 2 or 31 or the equivalent. ADVISORY: Completion of or concurrent enrollment in CAOT 44. DESCRIPTION: Knowledge of medical terminology and medical office procedures; proficiency in typing medical correspondence, case histories, insurance forms, and reports. Study of telephone techniques, medical record keeping, filing, and other office skills.

Table with columns: Section#, Time, Days, Instructor, Location. Row: 1018 LEC 10:35 am - 12:00 pm MTWTh BRONSON SMITH, C DH 202

COMPUTER APPLICATIONS OFFICE TECHNOLOGIES 023 - LEGAL SECRETARIAL PROCEDURES I (CSU) - 5.00 UNITS

PREREQUISITE: CAOT 1 or equivalent and eligibility for English 28. DESCRIPTION: Preparation of court pleadings and legal documents; knowledge of general law office

SECTION# TIME DAYS INSTRUCTOR LOCATION

procedures and specific procedures involved in litigation family law, corporate law, and other specialties; development of attitudes and behaviors appropriate for the legal field.

Table with columns: Section#, Time, Days, Instructor, Location. Row: 3466 LEC 6:50 pm - 9:20 pm T Th VARGAS, W I DH 203

COMPUTER APPLICATIONS OFFICE TECHNOLOGIES 031 - BUSINESS ENGLISH (CSU) - 3.00 UNITS

PREREQUISITE: English 28 and 67. Students learn English grammar and punctuation rules; practice in writing sentences and paragraphs.

Table with columns: Section#, Time, Days, Instructor, Location. Row: 1020 LEC 9:00 am - 10:25 am M W BELL, B DH 303

COMPUTER APPLICATIONS OFFICE TECHNOLOGIES 032 - BUSINESS COMMUNICATIONS (CSU) - 3.00 UNITS

PREREQUISITE: CAOT 1 and 31 with a satisfactory grade or better. (Credit allowed for only one of either CAOT 32 or Supervision 12.) DESCRIPTION: Principles and techniques of composing a variety of business communications.

Table with columns: Section#, Time, Days, Instructor, Location. Rows include 1021 LEC 9:00 am - 10:25 am T Th BELL, B DH 203, 3469 LEC 6:50 pm - 10:00 pm T HAYMON, S B DH 205

COMPUTER APPLICATIONS OFFICE TECHNOLOGIES 033 - RECORDS MANAGEMENT AND FILING - 2.00 UNITS

Students learn creation, storage, disposition and preservation of all types of documents using alphabetic, geographic, numeric, and subject methods. Includes database management on a microcomputer.

Table with columns: Section#, Time, Days, Instructor, Location. Rows include 1029 LEC 9:00 am - 10:00 am S HANA, B T DH 205, AND LAB 10:00 am - 12:10 pm S HANA, B T DH 205

COMPUTER APPLICATIONS OFFICE TECHNOLOGIES 034 - BUSINESS TERMINOLOGY (CSU) - 2.00 UNITS

DESCRIPTION: Correct definition, spelling, pronunciation, and effective usage of the general and specialized vocabulary used in modern business communications.

Table with columns: Section#, Time, Days, Instructor, Location. Row: 1001 LEC 10:35 am - 12:00 pm M W BELL, B DH 303

COMPUTER APPLICATIONS OFFICE TECHNOLOGIES 043 - OFFICE PROCEDURES - 3.00 UNITS Rpt 2

PREREQUISITE: CAOT 2 and CAOT 31. DESCRIPTION: Three hours weekly. Comprehensive knowledge and application of office skills and procedures for the automated office: development of attitudes for success on the job.

Table with columns: Section#, Time, Days, Instructor, Location. Row: 0320 LEC 9:00 am - 10:25 am M W SAMBRANO, R DH 203

COMPUTER APPLICATIONS OFFICE TECHNOLOGIES 044 - MEDICAL TERMINOLOGY (CSU) - 3.00 UNITS

Students develop an understanding of medical terminology through a study of word roots, prefixes, and suffixes and body systems. Students' emphasis is also given to spelling, pronunciation, and definitions.

Table with columns: Section#, Time, Days, Instructor, Location. Rows include 1033 LEC 9:00 am - 10:25 am M W BRONSON SMITH, C DH 202, 1244 LEC 9:00 am - 10:25 am T Th BRONSON SMITH, C DH 202

COMPUTER APPLICATIONS OFFICE TECHNOLOGIES 047 - APPLIED OFFICE PRACTICE (CSU) - 2.00 UNITS Rpt 3

ADVISORY: CAOT 1; or equivalent (ability to type 30 wpm) second semester standing. DESCRIPTION: Provides practical work experience in an office setting on campus.

Table with columns: Section#, Time, Days, Instructor, Location. Rows include 0321 LAB 10:35 am - 12:40 pm W DAY, T J AD 316, AND LAB - 3:05 hrs TBA DAY, T J TBA TBA

COMPUTER APPLICATIONS OFFICE TECHNOLOGIES 064 - COMPUTER APPLICATIONS AND OFFICE TECHNOLOGIES LABORATORY (CSU) - 1.00 UNITS Rpt 3

CO-REQUISITE: CAOT 1. DESCRIPTION: Provides additional lab time for students enrolled in Computer Applications - Office Technology classes to use a variety of software. See instructor anytime during the first week of classes in DH 202.

Table with columns: Section#, Time, Days, Instructor, Location. Row: 8392 LAB - 2:00 hrs TBA BRONSON SMITH, C DH 207

SECTION# TIME DAYS INSTRUCTOR LOCATION

COMPUTER APPLICATIONS OFFICE TECHNOLOGIES 082 - MICROCOMPUTER SOFTWARE SURVEY IN THE OFFICE (CSU) - 3.00 UNITS

PREREQUISITE: CAOT 1 with satisfactory grade or better or equivalent; CAOT 98 with satisfactory grade or better or equivalent. DESCRIPTION: Introduction to word processing, communication and disk operating systems. Introduction to spreadsheet and database application programs. Introduction to presentation graphics programs.

1035 LEC 10:35 am - 11:20 am MTWTh SAMBRANO, R DH 205
AND LAB 11:20 am - 12:00 pm MTWTh SAMBRANO, R DH 205

COMPUTER APPLICATIONS OFFICE TECHNOLOGIES 084 - MICROCOMPUTER OFFICE APPLICATIONS: WORD PROCESSING (CSU) - 3.00 UNITS Rpt 2

ADVISORY: Eligibility for ESL Level 6 CAOT and the ability to type 30 wpm accurately by touch. DESCRIPTION: Use basic and advanced functions of Word or WordPerfect including desktop publishing features to produce business documents.

1037 LEC 9:00 am - 11:05 am S MOTONAGA, L D DH 203
AND LAB 11:05 am - 2:15 pm S MOTONAGA, L D DH 203
1038 LEC 12:10 pm - 1:15 pm M W SAMBRANO, R DH 202
AND LAB 1:15 pm - 2:40 pm M W SAMBRANO, R DH 202
1039 LEC - 2:05 hrs TBA MORIMOTO, C S ON LINE
morimocs@lacitycollege.edu
AND LAB - 3:10 hrs TBA MORIMOTO, C S ON LINE

COMPUTER APPLICATIONS OFFICE TECHNOLOGIES 085 - MICROCOMPUTER OFFICE APPLICATIONS: SPREADSHEET (CSU) - 3.00 UNITS

Students learn office spreadsheet applications using a PC and spreadsheet application software, such as Excel. Students are taught to create, edit, format, and print worksheets; construct graphs and build databases that utilize the data table function.

1050 LEC - 1:05 hrs TBA DAY, T J ON LINE
daytj@lacitycollege.edu
AND LAB - 4:15 hrs TBA DAY, T J ON LINE

COMPUTER APPLICATIONS OFFICE TECHNOLOGIES 093 - LEGAL DOCUMENT PRODUCTION - 2.00 UNITS

CO-REQUISITE: Law 2 and CAOT 84. DESCRIPTION: This course is designed to link academic knowledge of Law 2 and the word processing skills of CAOT 84 to result in the production of legal documents as required by Law 2.

1045 LEC 10:35 am - 12:40 pm T VARGAS, W I DH 204

COMPUTER APPLICATIONS OFFICE TECHNOLOGIES 097 - INTRODUCTION TO THE INTERNET FOR CAOT - 3.00 UNITS Rpt 1

PREREQUISITE: Knowledge of Windows is helpful. DESCRIPTION: Students who enroll in lecture must attend three lab hours per week. This course provides is designed to prepare students to use the Worldwide Computer Network, Internet. The course emphasizes the features of the internet including electronic mail, file transfer protocol, internet explorer, and other services and utilities.

1042 LEC 12:10 pm - 1:10 pm M W PICKRELL, J E DH 205
AND LAB 1:15 pm - 2:40 pm M W PICKRELL, J E DH 205

COMPUTER APPLICATIONS OFFICE TECHNOLOGIES 098 - MICROCOMPUTER OFFICE APPLICATIONS: INTRO TO WINDOWS FOR OFFICE APPLICATIONS - 3.00 UNITS

Students prepare to work in the Windows environment. Emphasizes the feature of Windows, including changing and creating icons, opening and closing windows and other applications, responding to dialog boxes, and working with directories.

1043 LEC 7:25 am - 8:15 am MTWTh BENTLEY, R L DH 205
AND LAB 8:15 am - 8:50 am MTWTh BENTLEY, R L DH 205

SECTION# TIME DAYS INSTRUCTOR LOCATION

COMPUTER APPLICATIONS OFFICE TECHNOLOGIES 112 - MICROCOMPUTER OFFICE APPLICATIONS: WEB PAGE DESIGN (CSU) - 3.00 UNITS Rpt 2

ADVISORY: CAOT 98 or equivalent. DESCRIPTION: This course is designed to help students learn the most important topics of Web page design. The course emphasizes creating a new website, integrating a database, styles and networking with HTML code.

1051 LEC 12:10 pm - 1:10 pm M W GOSSETT, D DH 203
AND LAB 1:15 pm - 2:40 pm M W GOSSETT, D DH 203

COMPUTER APPLICATIONS OFFICE TECHNOLOGIES 126 - INTRODUCTION TO MEDICAL CODING/BILLING - 3.00 UNITS

PREREQUISITE: CAOT 44. DESCRIPTION: Introduction to the medical codes used for diagnostic and procedural data in medical billing. Introduction to medical billing forms the procedures required by Medicare and private medical insurance companies will also be covered.

1027 LEC 12:10 pm - 1:35 pm M W BRONSON SMITH, C DH 204

COMPUTER APPLICATIONS OFFICE TECHNOLOGIES 385 - DIRECTED STUDY - COMPUTER APPLICATIONS OFFICE TECHNOLOGY (CSU) - 3.00 UNITS

8393 LEC - 3:10 hrs TBA DAY, T J AD 316

COMPUTER APPLICATIONS OFFICE TECHNOLOGIES 931 - COOPERATIVE EDUCATION - CAOT (CSU) - 3.00 UNITS Rpt 3

9106 - 3:10 hrs TBA WERBLE, D M AD 209

COMPUTER APPLICATIONS OFFICE TECHNOLOGIES 941 - COOPERATIVE EDUCATION - CAOT (CSU) - 4.00 UNITS Rpt 3

9107 - 4:15 hrs TBA WERBLE, D M AD 209

COMPUTER SCIENCE-INFORMATION TECHNOLOGY
Chair: Roger Wolf, FH1010 (323) 953-4000 ext. 2810
<http://www.lacitycollege.edu/academic/departments/math/csitdept/>

For courses scheduled entirely on line, to complete your enrollment, you must email your professor and request course instructions. Email addresses for instructors can be accessed on the LACC website at <http://www.lacitycollege.edu/academic/departments/csit/faculty.html>, or by telephone call to the CSIT open laboratory at extension 2676.

COMPUTER SCIENCE-INFORMATION TECHNOLOGY 101 - INTRODUCTION TO COMPUTERS AND THEIR USES (UC:CSU) - 4.00 UNITS

ADVISORY: English 21/73 or equivalent. Credit not allowed if student has credit for CSIT 103. DESCRIPTION: A general computer literacy course open to all students. Presents computer hardware, software, terminology, ethics, and societal impact. Students will overview operating systems, word processing, spreadsheets, database management systems, telecommunications, and networks.

0248 LEC - 3:10 hrs TBA FLORES, L A ON LINE
AND LAB - 2:05 hrs TBA FLORES, L A ON LINE
0305 LEC 9:00 am - 12:10 pm S JAFFEE, M FH 201
AND - 2:05 hrs TBA JAFFEE, M ON LINE
0308 LEC 9:00 am - 10:25 am T Th TAVAKOLI, M FH 201
AND LAB - 1:55 hrs TBA TAVAKOLI, M ON LINE
0309 LEC 9:00 am - 10:25 am M W FLORES, L A FH 201
AND - 2:15 hrs TBA FLORES, L A ON LINE
0329 LEC - 3:30 hrs TBA DAKDUK, S ON LINE
AND LAB - 2:05 hrs TBA DAKDUK, S ON LINE
0330 LEC 10:35 am - 12:00 pm M W FLORES, L A FH 201
AND - 2:05 hrs TBA FLORES, L A ON LINE
1622 LEC 10:35 am - 12:00 pm T Th TAVAKOLI, M FH 201
AND - 2:05 hrs TBA TAVAKOLI, M ON LINE
3140 - 3:10 hrs TBA PASHAZADEH MONA ON LINE
AND - 2:05 hrs TBA PASHAZADEH MONA ON LINE
3141 LEC 6:50 pm - 10:00 pm W TAVAKOLI, M FH 201
AND - 2:05 hrs TBA TAVAKOLI, M ON LINE

SECTION# TIME DAYS INSTRUCTOR LOCATION

COMPUTER SCIENCE-INFORMATION TECHNOLOGY 103 - INTRODUCTION TO COMPUTER SYSTEMS FOR MIS (UC:CSU) - 4.00 UNITS

ADVISORY: English 21/73 or equivalent. DESCRIPTION: An introduction to computers for a one-semester transfer course or for certificates or a degree in CSIT. Topics include computers, programming and systems design, programming languages and flowcharting. Laboratory includes word processing, spreadsheets, database concepts and extensive programming in BASIC.

0256	LEC	-	3:10 hrs	TBA	TAVAKOLI, M	ON LINE
AND	LAB	-	2:05 hrs	TBA	TAVAKOLI, M	ON LINE
0317		-	3:10 hrs	TBA	PASHAZADEH MONA	ON LINE
AND		-	2:15 hrs	TBA	PASHAZADEH MONA	ON LINE
0318	LEC	9:00 am - 10:25 am		T Th	PASHAZADEH MONA	FH 208
AND	LAB	-	2:15 hrs	TBA	PASHAZADEH MONA	ON LINE
0319	LEC	10:35 am - 12:00 pm		M W	SAMPLEWALA, M	FH 208
AND		-	2:15 hrs	TBA	SAMPLEWALA, M	ON LINE
0331	LEC	9:00 am - 12:10 pm		S	PASHAZADEH MONA	FH 208
AND		-	2:05 hrs	TBA	PASHAZADEH MONA	ON LINE
3146		-	3:10 hrs	TBA	DAKDUK, S	ON LINE
AND		-	2:05 hrs	TBA	DAKDUK, S	ON LINE
3147	LEC	6:50 pm - 10:00 pm		Th	PAYES, H	FH 208
AND	LAB	-	2:15 hrs	TBA	PAYES, H	ON LINE

COMPUTER SCIENCE-INFORMATION TECHNOLOGY 104 - MATHEMATICS FOR PROGRAMMERS (CSU) - 3.00 UNITS

ADVISORY: CSIT 103.

0257	LEC	-	3:30 hrs	TBA	DAUZAT, B P	ON LINE
1627	LEC	9:00 am - 10:25 am		MTWTh	DAUZAT, B P	FH 202
<i>(8 Week Class - Starts 8/30/2010, Ends 10/21/2010)</i>						

COMPUTER SCIENCE-INFORMATION TECHNOLOGY 107 - PROGRAMMING LOGIC (UC:CSU) - 3.00 UNITS

PREREQUISITE: CSIT 103. ADVISORY: Mathematics 125.

0258	LEC	-	3:30 hrs	TBA	TAVAKOLI, M	ON LINE
0334	LEC	9:00 am - 10:25 am		MTWTh	DAUZAT, B P	FH 202
<i>(8 Week Class - Starts 10/25/2010, Ends 12/19/2010)</i>						

COMPUTER SCIENCE-INFORMATION TECHNOLOGY 108 - BEGINNING VISUAL BASIC PROGRAMMING (UC:CSU) - 3.00 UNITS

PREREQUISITE: CSIT 101 with a satisfactory grade or better or equivalent. DESCRIPTION: A beginning programming course in the Visual Basic Programming Language.

0336	LEC	12:30 pm - 3:40 pm		S	ATKINSON, P S	FH 208
------	-----	--------------------	--	---	---------------	--------

COMPUTER SCIENCE-INFORMATION TECHNOLOGY 134 - OPERATING SYSTEMS (CSU) - 3.00 UNITS

PREREQUISITE: CSIT 101 or CSIT 103.

3154	LEC	7:00 pm - 9:05 pm		T	BOLANDHEMAT, F	FH 201
AND	LAB	-	2:15 hrs	TBA	BOLANDHEMAT, F	ON LINE

COMPUTER SCIENCE-INFORMATION TECHNOLOGY 138 - ADVANCED VISUAL BASIC PROGRAMMING (UC:CSU) - 3.00 UNITS

PREREQUISITE: CO SCI 108. The student learns .NET programming language with objects, classes, exception handling, GUI,DBMS, SQL, ASP.NET, data structure and recursion.

0275	LEC	-	2:05 hrs	TBA	DAKDUK, S	ON LINE
AND	LAB	-	2:05 hrs	TBA	DAKDUK, S	ON LINE

COMPUTER SCIENCE-INFORMATION TECHNOLOGY 139 - PROGRAMMING IN C (UC:CSU) - 3.00 UNITS

PREREQUISITE: CSIT 103. The student learns all CS1 topics including Problem Analysis and Program Design, Simple Data Types, Streams and File I/O, Control Structures, Functions, Arrays, and Strings emphasizing procedural programming with C++.

1625	LEC	10:35 am - 12:45 pm		M W	DAUZAT, B P	FH 202
AND		-	4:20 hrs	TBA	DAUZAT, B P	ON LINE
<i>(8 Week Class - Starts 8/30/2010, Ends 10/21/2010)</i>						

SECTION# TIME DAYS INSTRUCTOR LOCATION

COMPUTER SCIENCE-INFORMATION TECHNOLOGY 140 - C++ PROGRAMMING II (UC:CSU) - 3.00 UNITS

PREREQUISITE: CSIT 139.

0335	LEC	10:35 am - 12:45 pm		M W	DAUZAT, B P	FH 202
AND	LAB	-	4:20 hrs	TBA	DAUZAT, B P	ON LINE
<i>(8 Week Class - Starts 10/25/2010, Ends 12/19/2010)</i>						

COMPUTER SCIENCE-INFORMATION TECHNOLOGY 141 - PROGRAMMING IN JAVA (UC:CSU) - 3.00 UNITS

PREREQUISITE: CSIT 101 or CSIT 103. ADVISORY: CSIT 107 and CSIT 104.

0328	LEC	12:20 pm - 2:25 pm		S	TITCHENELL, K G	FH 201
AND	LAB	2:35 pm - 4:40 pm		S	TITCHENELL, K G	FH 201

COMPUTER SCIENCE-INFORMATION TECHNOLOGY 151 - MACROMEDIA DREAMWEAVER I - 3.00 UNITS

PREREQUISITE: CSIT 101 or CSIT 103; ADVISORY: CO SCI 108

3661	LEC	7:00 pm - 9:10 pm		M	HAGHGOO, M	FH 208
AND		-	2:05 hrs	TBA	HAGHGOO, M	ON LINE

COMPUTER SCIENCE-INFORMATION TECHNOLOGY 152 - MACROMEDIA FLASH - 3.00 UNITS

ADVISORY: CO SCI 151.

3152	LEC	7:00 pm - 9:05 pm		T	GONSOSKI, S J	FH 208
AND		-	2:05 hrs	TBA	GONSOSKI, S J	ON LINE

COMPUTER SCIENCE-INFORMATION TECHNOLOGY 158 - HYPER-TEXT MARKUP LANGUAGE (CSU) - 3.00 UNITS

PREREQUISITE: CSIT 101. DESCRIPTION: A thorough coverage of Hyper-Text Markup Language, including style, multimedia devices, HTML code generators, Common Gateway Interface (CGI), CGI Script languages and programming order, processing and security considerations. Emphasis is on www page generation for business.

3649		-	2:05 hrs	TBA	HOLLIDAY, C C	ON LINE
AND		-	2:05 hrs	TBA	HOLLIDAY, C C	ON LINE

COMPUTER SCIENCE-INFORMATION TECHNOLOGY 186 - INTRODUCTION TO ORACLE: SQL AND PL/SQL (CSU) - 3.00 UNITS

The student learns the concepts of both relational and object relational databases and the SQL language. Students learn about data server technology and how to create and maintain database objects and how to store, retrieve, and manipulate data.

0347	LEC	-	2:05 hrs	TBA	DAKDUK, S	ON LINE
AND	LAB	9:00 am - 12:10 pm		S	DAKDUK, S	FH 301

COMPUTER SCIENCE-INFORMATION TECHNOLOGY 187 - ORACLE DBA PART 1A: ARCHITECTURE AND ADMINISTRATION - 3.00 UNITS

PREREQUISITE: CSIT 186. DESCRIPTION: This course is designed to give the students a firm foundation in basic administrative tasks and the necessary knowledge and skills to set up, maintain, and troubleshoot an oracle database. The students learn to use an administration tool to startup and shutdown a database, manage file and databasestorage, and manage users and their privileges.

0259	LEC	12:20 pm - 2:30 pm		S	SAMPLEWALA, M	FH 202
AND	LAB	-	3:10 hours	TBA	SAMPLEWALA, M	ONLINE

COMPUTER SCIENCE-INFORMATION TECHNOLOGY 188 - ORACLE DBA PART 1B: BACKUP AND RECOVERY - 3.00 UNITS

PREREQUISITE: CSIT 187. DESCRIPTION: This course introduces students to the critical task of planning and implementing database backup and recovery strategies. The class addresses backup and recovery techniques and examines various backup, failure, restore, and recovery scenarios. In hands-on exercises students examine backup methodologies based on business requirements in a mission critical enterprise.

0265	LEC		2:00-	TBA	SAMPLEWALA, M	ONLINE
AND	LAB	9:00 am - 12:10 pm		S	SAMPLEWALA, M	FH 202

COMPUTER TECHNOLOGY

Chair Roger Wolf, JH312G (323) 953-4000 ext. 2810
<http://www.lacitycollege.edu/academic/departments/ctel/index.html>

COMPUTER TECHNOLOGY 001 - INTRODUCTION TO COMPUTERS FOR TECHNICIANS (CSU) - 4.00 UNITS

ADVISORY: English 28 and 67 or equivalent. In this first course in the computer technology major students learn the physical aspects of computer hardware and low-level programming.

0350	LEC	9:00 am - 10:25 am	M W	HOLMES, G W	FH B06
AND	LAB	10:35 am - 12:00 pm	M W	HOLMES, G W	FH B06
3170	LEC	6:50 pm -10:00 pm	W	HOLMES, G W	FH B06
AND	LAB	6:50 pm -10:00 pm	M	HUMBLE, F F	FH B06

COMPUTER TECHNOLOGY 004 - INTRODUCTION TO COMPUTER NETWORKS - 4.00 UNITS

ADVISORY: Computer technology 1 or equivalent. DESCRIPTION: Introduces the concepts of networking, the OSI Model; methods of signaling and encoding; interfaces, modems, and transmission media; and examines the most important protocols involved in moving data over a communication network.

3048	LEC	6:50 pm -10:00 pm	W	VILLERAL, S M	FH B02
AND	LAB	6:50 pm -10:00 pm	M	VILLERAL, S M	FH B02

COMPUTER TECHNOLOGY 012 - INTRODUCTION TO COMPUTER HARDWARE (CSU) - 4.00 UNITS

This course is one of two courses, CT-12 and CT-14, that prepare students to take the Comp TIA A+ certification exam. The theory of the technology of computer hardware components: microprocessors, RAM, BIOS/CMOS, expansion bus, motherboard, power supply, HDD, FDD, CD, DVD, video and sound, and how these form a working system, maintenance and simple troubleshooting.

0352	LAB	9:00 am - 10:25 am	M W	SLAWINSKI, W M	FH B23
AND	LEC	10:35 am - 12:00 pm	M W	SLAWINSKI, W M	FH B23
3172	LEC	6:50 pm -10:00 pm	W	YAZDANIAN, M	FH B23
AND	LAB	6:50 pm -10:00 pm	M	YAZDANIAN, M	FH B23

COMPUTER TECHNOLOGY 014 - A-PLUS CERTIFICATION PREPARATION - 4.00 UNITS

This course is one of two courses, CT-12 and CT-14, that prepare students to take the Comp TIA A+ certification exam. The theory of the technology of portable computers and printers including understanding, installing, and upgrading Microsoft Windows operating systems, working with the Windows Command Line Interface, troubleshooting and maintenance of Windows, essentials of computer security, networking, and Internet is presented in this course.

1551	LEC	9:00 am - 10:25 am	T Th	YAZDANIAN, M	FH B09
AND	LAB	10:35 am - 12:00 pm	T Th	YAZDANIAN, M	FH B09
3692	LEC	6:50 pm -10:00 pm	T	YAZDANIAN, M	FH B09
AND	LAB	6:50 pm -10:00 pm	Th	YAZDANIAN, M	FH B09

COOPERATIVE EDUCATION

COOPERATIVE EDUCATION 195 - WORK EXPERIENCE - GENERAL I (CSU) - 1.00 UNITS Rpt 1

9490	LEC	- 0:55 hrs	TBA	WERBLE, D M	AD 209
------	-----	------------	-----	-------------	--------

COOPERATIVE EDUCATION 295 - WORK EXPERIENCE - GENERAL I (CSU) - 2.00 UNITS Rpt 2

9491	LEC	- 2:05 hrs	TBA	WERBLE, D M	AD 209
------	-----	------------	-----	-------------	--------

CORRECTIONS

Chair: Tim Sweetman, HH12 (323) 953-4000 ext 2753
<http://www.lacitycollege.edu/academic/departments/law/index.html>

CORRECTIONS 001 - INTRODUCTION TO CORRECTIONS (CSU) - 3.00 UNITS

Students learn the nature of the correctional system which includes: the aims and objectives of corrections, probation, institutions, services, supervision of inmates, and career opportunities

3041	LEC	3:30 pm - 6:40 pm	Th	CABALLERO, J C	HH 203
------	-----	-------------------	----	----------------	--------

DANCE SPECIALTIES

Chair: John Erdhaus, MG104 (323) 953-4000 ext 2851
<http://www.lacitycollege.edu/academic/departments/pe/index.html>

DANCE SPECIALTIES 440 - SOCIAL DANCE (CSU) - 1.00 UNITS Rpt 3

Students learn basic social dance steps and combinations, terminology, music, and appreciation of dance as an art form.

2908	LAB	6:50 pm - 9:00 pm	T	WHITMORE, C A	WG 206
-------------	------------	--------------------------	----------	----------------------	---------------

DANCE SPECIALTIES 446 - TAP DANCE 446 - 1.00 UNITS Rpt 2

2909	LAB	4:40 pm - 6:50 pm	Th	WHITMORE, C A	WG 206
-------------	------------	--------------------------	-----------	----------------------	---------------

DANCE SPECIALTIES 459 - FLAMENCO AND SPANISH DANCING (UC:CSU) - 1.00 UNITS Rpt 3

2007	LAB	10:00 am - 12:05 pm	T	GLICKMAN, D C	WG 206
2907	LAB	7:00 pm - 9:05 pm	M	GLICKMAN, D C	WG 206

DANCE STUDIES

Chair: John Erdhaus, MG104 (323) 953-4000 ext 2851
<http://www.lacitycollege.edu/academic/departments/pe/index.html>

DANCE STUDIES 185 - DIRECTED STUDY - DANCE (CSU) - 1.00 UNITS Rpt 2

8479	LAB	- 2:05 hrs	TBA	CUMMINS, D J	WG 204
------	-----	------------	-----	--------------	--------

DANCE STUDIES 452 - INTRODUCTION TO CHOREOGRAPHY (UC:CSU) - 1.00 UNITS Rpt 3

DESCRIPTION: This course introduces students to choreography with an emphasis on basic steps and combinations, creating dances, terminology, music, and appreciation of dance as a performing art form. Course may be taken four times.

2154	LAB	12:45 pm - 2:50 pm	T	SINGER, L	WG 202
------	-----	--------------------	---	-----------	--------

DANCE STUDIES 805 - HISTORY AND APPRECIATION OF DANCE (UC:CSU) - 3.00 UNITS Rpt 2

2911	LEC	6:50 pm -10:00 pm	W	SINGER, L	WG 102C
-------------	------------	--------------------------	----------	------------------	----------------

DANCE TECHNIQUES

Chair: Jan McEveety, WG101 (323) 953-4000 ext 2868
<http://www.lacitycollege.edu/academic/departments/pe/index.html>

DANCE TECHNIQUES 431 - MODERN DANCE (UC:CSU) - 1.00 UNITS Rpt 3

DESCRIPTION: This course introduces students to modern dance with an emphasis on basic steps and combinations, terminology, music, and appreciation of dance as a performing art form. Course may be taken four times.

2145	LAB	9:25 am - 10:25 am	M W	REISCH, M F	WG 202
2146	LAB	9:25 am - 10:25 am	T Th	REISCH, M F	WG 202
2928	LAB	6:50 pm - 8:55 pm	T	CUMMINS, D J	WG 202
2930	LAB	4:30 pm - 6:35 pm	W	CUMMINS, D J	WG 202

SECTION#	TIME	DAYS	INSTRUCTOR	LOCATION
----------	------	------	------------	----------

DANCE TECHNIQUES 434 - BALLET
(UC:CSU) - 1.00 UNITS Rpt 3

DESCRIPTION: This course introduces students to ballet with an emphasis on basic steps and combinations, terminology, music, and appreciation of dance as a performing art form. Course may be taken four times.

2147	LAB	1:45 pm - 3:50 pm	M	REISCH, M F	WG 202
2906	LAB	4:30 pm - 6:35 pm	M	REISCH, M F	WG 202
8476	LAB	1:45 pm - 3:50 pm	W	REISCH, M F	WG 202

DANCE TECHNIQUES 437 - JAZZ DANCE
(UC:CSU) - 1.00 UNITS Rpt 3

DESCRIPTION: This course introduces students to jazz dance with an emphasis on basic steps and combinations, terminology, music, and appreciation of dance as a performing art form. Course may be taken four times.

2150	LAB	10:35 am - 12:40 pm	M W	ECKLER, P	WG 202
<i>(8 Week Class - Starts 8/30/2010, Ends 10/20/2010)</i>					

2151	LAB	10:35 am - 12:40 pm	M W	ECKLER, P	WG 202
<i>(8 Week Class - Starts 10/25/2010, Ends 12/19/2010)</i>					

2932	LAB	4:00 pm - 6:05 pm	F	JENSEN, K L	WG 202
2933	LAB	6:50 pm - 8:55 pm	Th	SINGER, L	WG 206

DANCE TECHNIQUES 440 - SOCIAL DANCE
(UC:CSU) - 1.00 UNITS Rpt 3

2984	LAB	4:40 pm - 6:50 pm	M	JENSEN, K L	WG 206
-------------	------------	--------------------------	----------	--------------------	---------------

DANCE TECHNIQUES 466 - BALLET COMBINATIONS
(UC:CSU) - 1.00 UNITS Rpt 3

DESCRIPTION: This course introduces students to ballet combinations with an emphasis on basic steps and combinations, terminology, music, and appreciation of dance as a performing art form. Course may be taken four times.

8477	LAB	1:45 pm - 3:50 pm	W	REISCH, M F	WG 202
------	-----	-------------------	---	-------------	--------

DANCE TECHNIQUES 468 - JAZZ DANCE COMBINATION
(CSU) - 1.00 UNITS Rpt 3

2006	LAB	10:35 am - 12:40 pm	M W	ECKLER, P	WG 206
<i>(8 Week Class - Starts 10/25/2010, Ends 12/19/2010)</i>					

DANCE TECHNIQUES 469 - CONDITIONING FOR DANCE
(UC:CSU) - 1.00 UNITS Rpt 3

2005	LAB	1:45 pm - 3:55 pm	F	JENSEN, K L	WG 202
------	-----	-------------------	---	-------------	--------

DENTAL TECHNOLOGY

Chair: Dana Cohen, SCI 324A (323) 953-4000 ext 2501

<http://www.lacitycollege.edu/academic/departments/dentech/index.html>

DENTAL TECHNOLOGY 101 - ELEMENTS OF DENTAL TECHNOLOGY
- 2.00 UNITS

ADVISORY: English 73 or above. Open to all College students. DESCRIPTION: Orientation to the field of dental laboratory technology, including ethics, jurisprudence, history, and categories of employment.

0358	LEC	2:40 pm - 4:50 pm	F	GABRIE, C C	SCI 126
------	-----	-------------------	---	-------------	---------

DENTAL TECHNOLOGY 102 - DENTAL ANATOMY AND TERMINOLOGY - 3.00 UNITS

ADVISORY: English 73 or above. Open to all College students. DESCRIPTION: Study of the oral cavity, including anatomy, histology, osteology, myology, form and function.

0359	LEC	1:00 pm - 2:30 pm	M F	COHEN, A S	SCI 126
------	-----	-------------------	-----	------------	---------

DENTAL TECHNOLOGY 103 - COMPLETE DENTURE PROSTHETICS I - 5.00 UNITS

PREREQUISITE: Dental Technology 100. ADVISORY: English 73 or above. DESCRIPTION: Beginning techniques and skills of complete denture construction and laboratory procedures.

0360	LEC	1:35 pm - 3:00 pm	T Th	GABRIE, C C	SCI 307
AND	LAB	3:00 pm - 5:30 pm	T Th	GABRIE, C C	SCI 307

SECTION#	TIME	DAYS	INSTRUCTOR	LOCATION
----------	------	------	------------	----------

DENTAL TECHNOLOGY 105 - COMPLETE DENTURE PROSTHETICS III - 2.00 UNITS

PREREQUISITE: Dental Technology 103. ADVISORY: English 73 or above. DESCRIPTION: Construction of maxillary and mandibular dentures in balanced occlusion.

0327	LEC	1:00 pm - 2:00 pm	M	GABRIE, C C	SCI 307
AND	LEC	2:00 pm - 5:20 pm	M	GABRIE, C C	SCI 307

DENTAL TECHNOLOGY 108 - GNATHOLOGICAL CONCEPTS - 3.00 UNITS

PREREQUISITE: Dental Technology 109 A study of advanced occlusion concepts. Organic waxing of the occlusal surfaces will be accomplished on fully adjustable articulators, includes maxillary and mandibular posterior and anterior dentition.

0338	LEC	1:00 pm - 3:05 pm	F	COHEN, D B	SCI 313
AND	LAB	3:10 pm - 5:15 pm	F	COHEN, D B	SCI 313

DENTAL TECHNOLOGY 109 - FIXED PROSTHETICS I - 4.00 UNITS

PREREQUISITE: Dental Technology 100. ADVISORY: English 73 or above. DESCRIPTION: Introduction to the technique of making precision dental castings from wax patterns.

0364	LEC	1:00 pm - 2:00 pm	M W	COHEN, D B	SCI 313
AND	LAB	2:00 pm - 5:30 pm	M W	COHEN, D B	SCI 313

DENTAL TECHNOLOGY 111 - FIXED PROSTHETICS II - 5.00 UNITS

PREREQUISITE: Dental Technology 109 Waxing single and multiple units by using PTC techniques and methodology based on student learning outcomes. Learning and understanding concepts such as: tooth contour alignment, functional and morphological occlusion. Applied techniques in sprung, investing and casting including soldering are part of the course outline.

0332	LEC	1:35 pm - 3:05 pm	T Th	COHEN, A S	SCI 313
AND	LAB	3:05 pm - 5:55 pm	T Th	COHEN, A S	SCI 313

DENTAL TECHNOLOGY 112 - REMOVABLE PARTIAL DENTURE PROSTHETICS I - 3.00 UNITS

PREREQUISITE: Dental Technology 103. DESCRIPTION: An introduction to the study of removable partial denture construction, use of the dental surveyor, design of the partial, waxing and casting techniques.

0333	LEC	1:00 pm - 2:50 pm	W	GABRIE, C C	SCI 307
AND	LAB	2:50 pm - 4:40 pm	W	GABRIE, C C	SCI 307

DENTAL TECHNOLOGY 203 - METAL CERAMIC RESTORATIONS - 2.00 UNITS

PREREQUISITE: Dental Technology 206. DESCRIPTION: A course in metal ceramic restorations, including properties, design, manipulation, firing, staining, glazing, polishing and esthetics. Single, soldered and multiple unit bridgework are covered.

1325	LEC	8:00 am - 8:50 am	W	COHEN, A S	SCI 313
AND	LAB	8:55 am - 12:05 pm	W	COHEN, A S	SCI 313

DENTAL TECHNOLOGY 205 - ADVANCED REMOVABLE PARTIAL DENTURES - 10.00 UNITS Rpt 1

PREREQUISITE: Dental Technology 105 and 112. DESCRIPTION: This course is the first course for Removable Prosthetic Specialist in the Dental Technology Program. This course incorporates advanced removable partial denture design, and manufacturing techniques.

8388	LEC	7:45 am - 9:55 am	T Th	COHEN, D B	SCI 307
AND	LAB	9:55 am - 12:05 pm	T Th	COHEN, D B	SCI 307
AND	LAB	8:45 am - 11:55 am	M F	COHEN, A S	SCI 313
AND	LAB	7:45 am - 8:45 am	M F	COHEN, A S	SCI 313

DENTAL TECHNOLOGY 206 - ADVANCED REMOVABLE PARTIAL DENTURES - 10.00 UNITS Rpt 1

PREREQUISITE: Dental Technology 105 and 112. DESCRIPTION: This course is the first course for Removable Prosthetic Specialist in the Dental Technology Program. This course incorporates advanced removable partial denture design, and manufacturing techniques.

0344	LEC	7:45 am - 9:55 am	T Th	COHEN, D B	SCI 307
------	-----	-------------------	------	------------	---------

SECTION#	TIME	DAYS	INSTRUCTOR	LOCATION
AND LAB	9:55 am - 12:05 pm	T Th	COHEN, D B	SCI 307
AND LAB	8:45 am - 11:55 am	M F	COHEN, A S	SCI 313
AND LAB	7:45 am - 8:45 am	M F	COHEN, A S	SCI 313

DENTAL TECHNOLOGY 301 - MACRO AND MICRO ESTHETICS - 3.50 UNITS Rpt 1

DESCRIPTION: This course will cover the inter-tooth components of the esthetic smile and the intra-tooth component of an individual tooth.

8601 LEC	7:00 am - 9:40 am	M	STAFF	UCLA UCLA
AND LAB	9:40 am - 2:30 pm	M	STAFF	UCLA UCLA

DENTAL TECHNOLOGY 303 - SKELETON BUILD-UP FOR PORCELAIN FUSED TO METAL - 4.00 UNITS Rpt 1

DESCRIPTION: This course will focus on the design and fabrication of Composite Metal single and multiple unit restorative substructures and the skeleton build-up porcelain technique to complete the dental esthetic restorations.

8603 LEC	8:00 am - 9:30 am	T	STAFF	UCLA UCLA
AND LAB	9:30 am - 5:00 pm	T	STAFF	UCLA UCLA
AND LAB	8:00 am - 11:30 am	W	STAFF	UCLA UCLA

DENTAL TECHNOLOGY 304 - SKELETON BUILD-UP FOR ALL CERAMIC RESTORATIONS - 4.00 UNITS Rpt 1

DESCRIPTION: This course will focus on the design and fabrication of All-ceramic single and multiple unit restorative substructures and the skeleton build-up porcelain technique to complete the dental esthetic restorations

8604 LEC	12:00 pm - 1:30 pm	W	STAFF	UCLA UCLA
AND LAB	1:30 pm - 5:00 pm	W	STAFF	UCLA UCLA
AND LAB	8:00 am - 3:00 pm	Th	STAFF	UCLA UCLA

DENTAL TECHNOLOGY 402 - ADVANCED PROSTHODONTICS 1 - 14.00 UNITS Rpt 2

PREREQUISITE: Dental Technology 401. DESCRIPTION: This course includes lecture and laboratory in planning and fabrication of advanced implant, fixed and movable prosthodontics and dental ceramics.

8606 LEC	8:00 am - 9:20 am	MTWThF	STAFF	UCLA UCLA
AND LAB	9:20 am - 5:30 pm	MTWThF	STAFF	UCLA UCLA

EARTH SCIENCE

Chair: John Freitas, SCI 324B (323) 953-4000 ext 2600
<http://www.lacitycollege.edu/academic/departments/chemistry/>

EARTH SCIENCE 001 - EARTH SCIENCE (UC:CSU) - 3.00 UNITS

ADVISORIES: English 28 and 67 or its equivalent. The student receives a general introduction to the study of the earth's rocks, landforms, atmosphere, and oceans.

3181 LEC	6:50 pm - 10:00 pm	T	HURST, T A	SCI 200
----------	--------------------	---	------------	---------

ECONOMICS

Chair: Wendel Eckford, FH211E (323) 953-4000 ext. 2561
<http://www.lacitycollege.edu/citymain/academic.html#SUBJECT/AREA>

ECONOMICS 395 - WORK EXPERIENCE - GENERAL I (CSU) - 3.00 UNITS Rpt 3

9492 LEC	- 3:10 hrs	TBA	WERBLE, D M	AD 209
----------	------------	-----	-------------	--------

ECONOMICS 001 - PRINCIPLES OF ECONOMICS I (UC:CSU) - 3.00 UNITS

ADVISORY: English 28 or equivalent. DESCRIPTION: A course in microeconomics introducing the principles and methods of economic analysis, economic institutions, and issues of economic policy.

0376 LEC	9:00 am - 10:25 am	T Th	HOLZNER, J E	FH 223
0377 LEC	10:35 am - 12:00 pm	M W	HOLZNER, J E	FH 223
0378 LEC	1:45 pm - 3:10 pm	M W	HOLZNER, J E	FH 223
Special tutorial assistance available to students in section 0378.				
0383 LEC	10:35 am - 12:00 pm	T Th	HOLZNER, J E	FH 223
3182	- 3:10 hrs	TBA	HOLZNER, J E	ON LINE
3184 LEC	6:50 pm - 10:00 pm	T	STAFF	FH 223

SECTION#	TIME	DAYS	INSTRUCTOR	LOCATION
ECONOMICS 002 - PRINCIPLES OF ECONOMICS II (UC:CSU) - 3.00 UNITS				

ADVISORY: English 28 or equivalent. DESCRIPTION: A course in macroeconomics emphasizing aggregative economic analysis, including money and banking, national income determination, business fluctuations, and other topics relevant to macroeconomic analysis.

0380	- 2:50 hrs	TBA	HOLZNER, J E	ON LINE
------	------------	-----	--------------	---------

ELECTRONICS

Chair: Roger Wolf, FH1010 (323) 953-4000 ext. 2810
<http://catalog.lacitycollege.edu/pages/electronics.html>

ELECTRONICS 002 - INTRODUCTION TO ELECTRONICS (CSU) - 3.00 UNITS

PREREQUISITE: None. Open to all students except Electronics and Computer Technology majors. DESCRIPTION: DA survey of Electronics and its impact on society. Introduction to the technological implications of electronics through hands-on exposure to basic electronic principles.

0392 LEC	1:45 pm - 3:10 pm	T Th	YAZDANIAN, M	FH B07
----------	-------------------	------	--------------	--------

ELECTRONICS 004 - FUNDAMENTALS OF ELECTRONICS I (CSU) - 4.00 UNITS

COREQUISITE: Electronics 10. Students learn the concepts of direct current circuits, including basics of electricity, series and parallel circuits, meters, batteries, resistors, and magnetism. The laboratory emphasizes skills in the analysis of circuits and the use of test equipment.

0393 LEC	9:00 am - 10:25 am	T Th	HOLMES, G W	FH B07
AND LAB	10:35 am - 12:00 pm	T Th	HOLMES, G W	FH B07

ELECTRONICS 008 - ELECTRON DEVICES (CSU) - 4.00 UNITS

PREREQUISITE: Electronics 4. The student learns the nature and operation of solid state devices including diodes, transistors, and field effect devices. Includes simple circuit applications.

0395 LEC	9:00 am - 10:25 am	M W	SARKISSIAN, R	FH B07
AND LAB	10:35 am - 12:00 pm	M W	SARKISSIAN, R	FH B07

ELECTRONICS 010 - MATHEMATICS OF ELECTRONICS I (CSU) - 3.00 UNITS

The student learns mathematical methods and techniques for the solution of basic DC circuit problems including the study of algebraic operations, simple linear equations, algebraic fractions, ratio and percent, graphing, and use of the electronic calculator.

0394 LEC	12:10 pm - 1:35 pm	T Th	SPROTT, L B	FH B04
----------	--------------------	------	-------------	--------

ELECTRONICS 101 - SCIENCE ELECTRONICS (CSU) - 3.00 UNITS

DESCRIPTION: Open to all students. A survey of electronics technology in the context of the principles of science. The application of the methods of Science, Technology, Engineering, and Mathematics (STEM) to topics ranging from basic circuits to complex integrated devices, and the products that use them. Includes topics in electronic music, computers, robotics, digital communication, and a variety of existing technologies. Social, political, and economic impacts of electronic technology are explored. Electronics 002 is strongly recommended as an accompanying laboratory course. This course satisfies the general education requirement for a science elective.

3052 LEC	6:50 pm - 10:00 pm	T	PEREZ, C E	FH B06
----------	--------------------	---	------------	--------

ENGINEERING, ELECTRICAL

Chair: Jayesh Bhakta, SCI222D (323) 953-4000 ext 2923
<http://catalog.lacitycollege.edu/pages/engineering.html>

ENGINEERING, ELECTRICAL 220 - ELECTRICAL CIRCUITS I (UC:CSU) - 4.00 UNITS

PREREQUISITE: Physics 102. CO-REQUISITE: Mathematics 275. Students learn the theory of circuit analysis and practice its application to areas of importance in electrical engineering such as DC, AC, operational amplifiers, multi-phase power, and frequency response. Students also perform laboratory exercises to learn how to realize circuit

SECTION#	TIME	DAYS	INSTRUCTOR	LOCATION
----------	------	------	------------	----------

designs using electronic components and to use instruments such as multimeters, oscilloscopes, and signal generators.

3666	LEC	6:50 pm -10:00 pm	T	BHAKTA, J	FH 308
AND	LAB	6:50 pm -10:00 pm	Th	BHAKTA, J	FH 308

ENGINEERING, GENERAL

Chair: Jayesh Bhakta, SCI222D (323) 953-4000 ext 2923
<http://catalog.lacitycollege.edu/pages/engineering.html>

ENGINEERING, GENERAL 101 - INTRODUCTION TO SCIENCE, ENGINEERING AND TECHNOLOGY (UC:CSU) - 2.00 UNITS

Students learn about the engineering method and strategies for academic and career success in engineering. Students are introduced to mechanical, civil, electrical, and computer systems engineering through project work. The vast range disciplines and opportunities in engineering are presented. Students are guided through challenging design exercises to develop skills in planning, communication, team working, and creativity. Only basic mathematics skills are required

3179	LEC	4:30 pm - 6:30 pm	Th	DATIS, A P	SCI 126
-------------	------------	--------------------------	-----------	-------------------	----------------

ENGINEERING, GENERAL 212 - CADD FOR ENGINEERS II (UC:CSU) - 3.00 UNITS Rpt 3

Students develop 3-D representations of engineering components and assemblies using Solidworks feature based parametric solid modeling software. Instruction is given in the types of solid object manipulations that are common to all parametric solid modeling software used in industry to construct components that can be further combined to make assemblies. The preparation of engineering drawings from the 3-D representation using automation tools is also covered.

0405	LEC	10:35 am - 12:45 pm	S	DANIEL BERHE, S K	SCI 208
AND	LAB	12:45 pm - 2:55 pm	S	DANIEL BERHE, S K	SCI 208

ENGINEERING, GENERAL 241 - STRENGTH OF MATERIALS (UC:CSU) - 3.00 UNITS

Prerequisite: General Engineering 131. The student learns the application of mechanics to determining the effect of forces and torques on materials. The student will be able to apply this knowledge to the design of load bearing components. The course will cover the following topics: stress, strain, axial loading, torsion, flexural stresses, transverse shear stress, horizontal shear stresses, stress transformations, Mohr's circle, pressure vessels, shear and bending moment diagrams, stresses in a beam, methods of superposition, and elastic strain energy.

3667	LEC	6:50 pm - 9:00 pm	M	CUEVAS, G N	FH 308
AND	LAB	6:50 pm -10:00 pm	W	CUEVAS, G N	FH 308

ENGLISH

Chair: Tammy Robinson, SCI324N (323) 953-4000 ext 2700
<http://catalog.lacitycollege.edu/pages/english.html>

ENGLISH 020 - COLLEGE READING SKILLS (NDA) - 6.00 UNITS

Prerequisite: Appropriate score on the English Placement Exam. Students receive instruction in techniques of writing clear, coherent compositions and improvement in reading skills which reinforce writing skills necessary for academic success.

0414	LEC	8:55 am - 12:05 pm	T Th	HARRIS, F	HH 106
0416	LEC	1:45 pm - 4:55 pm	T Th	BARNES, Y M	FH B04
0498	LEC	12:10 pm - 3:20 pm	M W	MARTINEZ, S P	FH B02

Special tutorial assistance available to students in section 0498.

3197	LEC	6:50 pm -10:00 pm	M W	GOULD, R L	FH B24
-------------	------------	--------------------------	------------	-------------------	---------------

ENGLISH 021 - ENGLISH FUNDAMENTALS (NDA) - 3.00 UNITS

PREREQUISITE: English 20, ESL 6A or appropriate placement score. DESCRIPTION: Introduction to English fundamentals, focusing on grammar, reading, and writing skills, with additional individual tutoring and writing practice in the Writing Center of the English/ESL Department.

0444	LEC	9:00 am - 12:00 pm	S	JONAS, V P	FH 205
0529	LEC	1:55 pm - 3:20 pm	M W	DANCOFF, J	FH B09
3236	LEC	6:50 pm -10:00 pm	M	ELIZONDO, S A	FH B12

SECTION#	TIME	DAYS	INSTRUCTOR	LOCATION
----------	------	------	------------	----------

ENGLISH 028 - INTERMEDIATE READING AND COMPOSITION - 3.00 UNITS

PREREQUISITE: English 21, 73 or 97; ESL 6A; or Placement Exam; COREQUISITE: English 67 Students receive instruction in techniques of writing at the college level. Students develop writing and reading skills, with emphasis on grammar, various essay writing, and analysis of fiction and non-fiction materials.

0418		- 6:00 hrs	TBA	LAPP, R E	ON LINE
<i>(8 Week Class - Starts 8/30/2010, Ends 10/24/2010)</i>					
0422	LEC	10:35 am - 12:00 pm	M W	ZIMBLER, J L	HH 107
0425	LEC	9:00 am - 10:25 am	M W	EISENSTEIN, S A	FH 205
0426	LEC	10:35 am - 12:00 pm	T Th	HERNANDEZ, L A	FH B24
0427	LEC	9:00 am - 10:25 am	T Th	MACK, S J	FH 303
0430	LEC	12:10 pm - 1:35 pm	M W	BRANDLER, M Y	FH B04
0431	LEC	9:00 am - 12:10 pm	T Th	MAECK, A T	HH 205
<i>(8 Week Class - Starts 8/30/2010, Ends 10/23/2010)</i>					
0433	LEC	12:10 pm - 1:35 pm	M W	NISHIOKA, A	FH B27
0442	LEC	10:35 am - 12:00 pm	M W	MEDICI, J A	FH B04
0446	LEC	1:45 pm - 3:10 pm	T Th	CRAN, K	FH B27
1332	LEC	1:45 pm - 4:55 pm	S	SMITH, L T	FH B26
1338	LEC	- 3:10 hrs	TBA	ROBINSON, T R	ON LINE
1616	LEC	1:45 pm - 3:15 pm	M W	SIDER, J	FH B26
1617	LEC	9:00 am - 10:25 am	T Th	ROSE, P	FH B12
3018	LEC	6:50 pm -10:00 pm	M	CASEY, P	FH 223
3043	LEC	3:30 pm - 4:55 pm	M W	STAFF	FH B09
3201	LEC	6:50 pm -10:00 pm	W	STAFF	FH B04
3203	LEC	6:50 pm -10:00 pm	T	JEWETT, K	FH B24
3204	LEC	3:30 pm - 6:40 pm	W	CARAM, E L	FH B27
3207	LEC	6:50 pm -10:00 pm	Th	MURRAY, G A	FH B27
3209	LEC	3:30 pm - 6:40 pm	Th	DES VIGNES, M	FH B12
3700	LEC	3:30 pm - 5:00 pm	M W	STAFF	FH B26
3701	LEC	6:50 pm -10:10 pm	W	ROWE, K	HH 7
3702	LEC	6:50 pm -10:00 pm	Th	YOUNG SINGLETON,	FH B12

ENGLISH 067 - WRITING LABORATORY (NDA) - 0.50 UNITS Rpt 3

DESCRIPTION: Individual help in improving college writing: organization, clarity, and mechanics. Enroll through 12th week of semester by Add Card.

0279	LAB	- 1:00 hrs	TBA	STAFF	AD 318
0284	LAB	- 1:00 hrs	TBA	STAFF	AD 318
0285	LAB	- 1:00 hrs	TBA	STAFF	AD 318
0288	LAB	- 1:00 hrs	TBA	STAFF	AD 318
0289	LAB	- 1:00 hrs	TBA	STAFF	AD 318
0297	LAB	- 1:00 hrs	TBA	STAFF	AD 318
0298	LAB	- 1:00 hrs	TBA	STAFF	AD 318
0302	LAB	- 1:00 hrs	TBA	STAFF	AD 318
0303	LAB	- 1:00 hrs	TBA	STAFF	AD 318
0304	LAB	- 1:00 hrs	TBA	STAFF	AD 318
0306	LAB	- 1:00 hrs	TBA	STAFF	AD 318
0307	LAB	- 1:00 hrs	TBA	STAFF	AD 318
0434	LAB	- 1:00 hrs	TBA	STAFF	AD 318
0435	LAB	- 1:00 hrs	TBA	STAFF	AD 318
0481	LAB	- 1:05 hrs	TBA	BRYER, E	AD 318
0482	LAB	- 1:00 hrs	TBA	STAFF	AD 318
0483	LAB	- 1:00 hrs	TBA	STAFF	AD 318
0484	LAB	- 1:00 hrs	TBA	STAFF	AD 318
0489	LAB	- 1:00 hrs	TBA	STAFF	AD 318
0490	LAB	- 1:00 hrs	TBA	STEVENSON, T	AD 318
0491	LAB	- 1:00 hrs	TBA	ZIMBLER, J L	AD 318
0492	LAB	- 1:00 hrs	TBA	LEVIN, R B	AD 318
0493	LAB	- 1:00 hrs	TBA	STAFF	AD 318
0494	LAB	- 1:00 hrs	TBA	STAFF	AD 318
0495	LAB	- 1:00 hrs	TBA	STAFF	AD 318

ENGLISH COURSE SEQUENCE

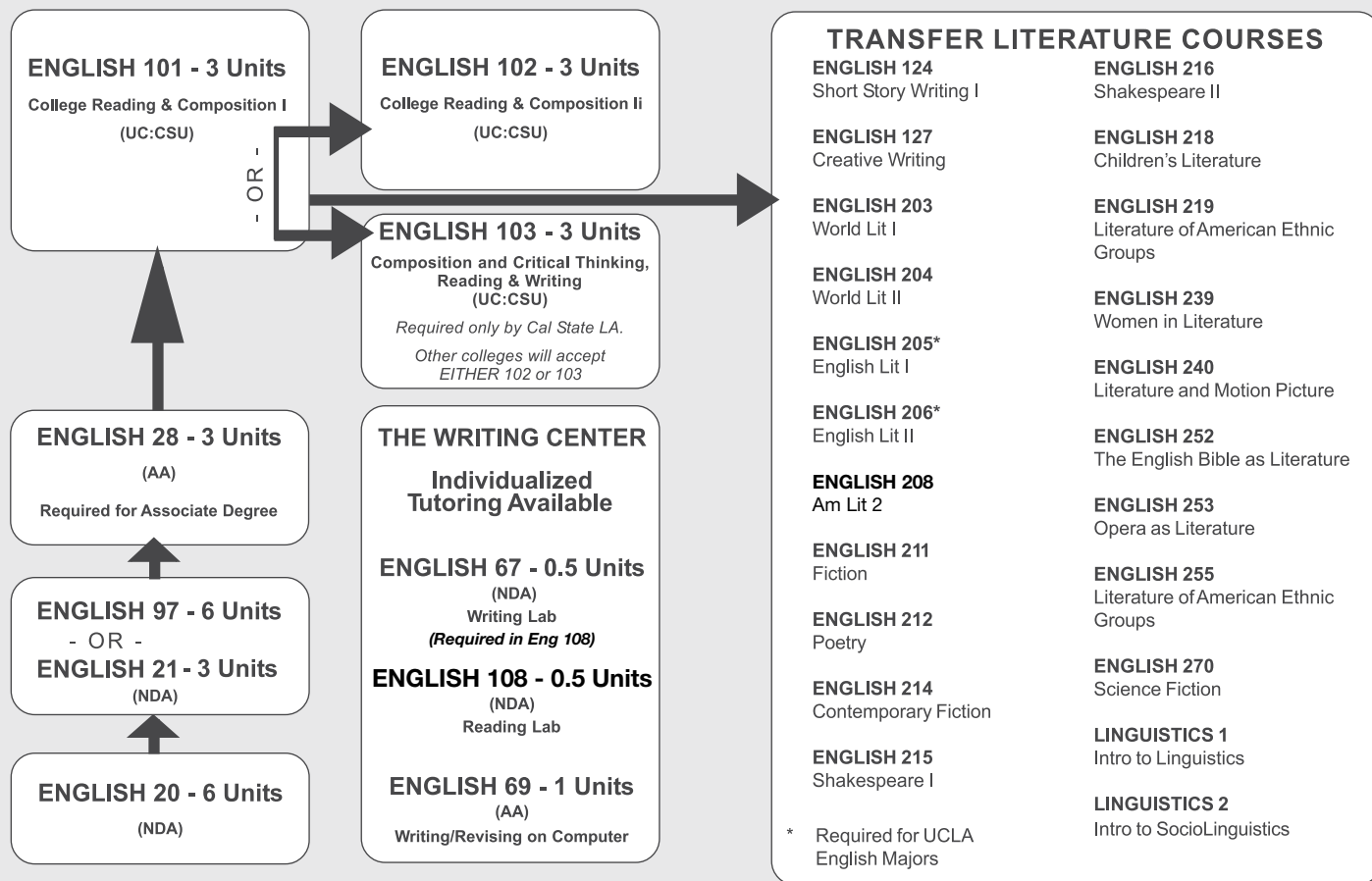

TRANSFER LITERATURE COURSES	
ENGLISH 124 Short Story Writing I	ENGLISH 216 Shakespeare II
ENGLISH 127 Creative Writing	ENGLISH 218 Children's Literature
ENGLISH 203 World Lit I	ENGLISH 219 Literature of American Ethnic Groups
ENGLISH 204 World Lit II	ENGLISH 239 Women in Literature
ENGLISH 205* English Lit I	ENGLISH 240 Literature and Motion Picture
ENGLISH 206* English Lit II	ENGLISH 252 The English Bible as Literature
ENGLISH 208 Am Lit 2	ENGLISH 253 Opera as Literature
ENGLISH 211 Fiction	ENGLISH 255 Literature of American Ethnic Groups
ENGLISH 212 Poetry	ENGLISH 270 Science Fiction
ENGLISH 214 Contemporary Fiction	LINGUISTICS 1 Intro to Linguistics
ENGLISH 215 Shakespeare I	LINGUISTICS 2 Intro to SocioLinguistics

* Required for UCLA English Majors

0496	LAB	-	1:00 hrs	TBA	ROBINSON, T R	ON LINE
0497	LAB	-	1:05 hrs	TBA	ROBINSON NEARY,	ON LINE

ENGLISH 069 - WRITING AND REVISING ON THE COMPUTER - 1.00 UNITS Rpt 3

DESCRIPTION: Enroll in AD 318 or CCW 229 through the 12th week of the semester by ADD CARD. Students use computers to improve their writing skills including organizing, spelling, punctuation, and mechanics.

0156	LAB	-	2:05 hrs	TBA	GORDON, E M	AD 318
0164	LAB	-	2:05 hrs	TBA	GORDON, E M	AD 318
0168	LAB	-	2:05 hrs	TBA	LEVIN, R B	AD 318
0438	LAB	-	2:05 hrs	TBA	GORDON, E M	CCW 229

ENGLISH 078 - WRITING MEMOIR - 3.00 UNITS Rpt 2

DESCRIPTION: This course focuses on writing personal memoir. Students will read full length memoirs and compose their own, and in the process discover new meanings from their pasts.

3215	LEC	6:50 pm -10:00 pm	Th		RYAN, J M	FH 223
-------------	------------	--------------------------	-----------	--	------------------	---------------

ENGLISH 094 - INTENSIVE GRAMMAR REVIEW (NDA) - 3.00 UNITS

ADVISORIES: English 21, English 67. Students engage in an intensive review of grammar and sentence structure to better prepare them for English 28 or 101.

0445	LEC	1:45 pm - 3:10 pm	T Th		STAFF	HH 106
1605	LEC	9:00 am - 10:25 am	M W		TAMAYO, F	TBA TBA

ENGLISH 097 - INTRODUCTION TO COLLEGE ENGLISH AND READING SKILLS (NDA) - 6.00 UNITS

PREREQUISITES: English 20 or Placement Exam, ADVISORIES: English 47 or 67. Students will be introduced to English fundamental in formal academic writing, focusing on basic grammar, reading, and writing skills. There will also be an introduction to English grammar, college vocabulary, and academic writing skills as well as instruction in comprehending expository articles, narratives, and college-level textbook material.

0262	LEC	10:35 am - 1:45 pm	M W		TAMAYO, F	TBA TBA
1611	LEC	9:00 am - 12:10 pm	M W		TCHEN, B W	LS 102
1612	LEC	1:45 pm - 5:05 pm	M W		STAFF	FH B12
1613	LEC	12:10 pm - 3:30 pm	M W		SILVER, R H	HH 107
Special tutorial assistance available to students in section 1613.						
1614	LEC	1:45 pm - 5:00 pm	T Th		BRYER, E	FH 205
1629	LEC	10:35 am - 1:45 pm	M W		MIKLOS, M J	FH B09
1630	LEC	9:00 am - 12:10 pm	M W		KENDALL, E W	FH 302

Special tutorial assistance available to students in section 1630.

1631	LEC	9:00 am - 12:10 pm	T Th		SOTIRIOU, P E	HH 107
Special tutorial assistance available to students in section 1631.						
1632	LEC	9:00 am - 12:10 pm	T Th		MARTINEZ, S P	FH B02
3162	LEC	6:50 pm -10:10 pm	M W		RUIZ, D	FH 303
3653	LEC	3:30 pm - 6:40 pm	T Th		STAFF	FH B24
3698	LEC	6:50 pm -10:05 pm	T Th		ALESSI, J	FH B04

SECTION# TIME DAYS INSTRUCTOR LOCATION

ENGLISH 101 - COLLEGE READING AND COMPOSITION I (UC:CSU) - 3.00 UNITS

PREREQUISITE: English 28 and 67 or 31 or appropriate placement score. ADVISORY: English 108. DESCRIPTION: English 101 is a transferable course that develops proficiency in college-level reading and writing through practice of critical thinking and well-developed expository writing.

0326	LEC	10:35 am - 12:00 pm	M W	COLOMBO, G J	TBA TBA
0403	LEC	10:35 am - 12:00 pm	T Th	NISHIMURA, J M	FH B27
0404	LEC	9:00 am - 10:25 am	M W	LYNCH, J J	FHB04
0407	LEC	1:45 pm - 3:10 pm	T Th	MULLER, D N	FH B02
0451	LEC	9:00 am - 10:25 am	M W	NISHIMURA, J M	FH 303
0454	LEC	9:00 am - 12:00 pm	T Th	MAECK, A T	HH 205
<i>(8 Week Class - Starts 10/25/2010, Ends 12/19/2010)</i>					
0456	LEC	9:00 am - 10:25 am	T Th	EISENSTEIN, S A	FH 205
0459	LEC	9:00 am - 12:00 pm	S	STAFF	FH 302
0460	LEC	10:35 am - 12:00 pm	M W	MULLER, D N	FH B02
0462	LEC	9:00 am - 10:25 am	T Th	MIKLOS, M J	FH B04
0465	LEC	10:35 am - 12:00 pm	T Th	MIKLOS, M J	FH B12
0479	LEC	- 3:10 hrs	TBA	ROBINSON, T R	ON LINE
0480	LEC	9:00 am - 10:25 am	T Th	MANOS, H C	FH B24
0486	LEC	1:45 pm - 3:10 pm	M W	STAFF	FH B24
0588		- 6:30 hrs	TBA	LAPP, R E	ON LINE
<i>(8 Week Class - Starts 10/25/2010, Ends 12/19/2010)</i>					
1615	LEC	9:00 am - 10:25 am	M W	STEVENSON, T	FH B09
1619	LEC	9:00 am - 12:20 pm	M W	STAFF	CHEM 201
<i>(8 Week Class - Starts 8/30/2010, Ends 10/24/2010)</i>					
3221	LEC	6:50 pm - 10:00 pm	T Th	MAECK, A T	FH B02
<i>(8 Week Class - Starts 8/30/2010, Ends 10/23/2010)</i>					
3222	LEC	3:30 pm - 6:40 pm	Th	LIPMAN, D N	FH B26
3223	LEC	6:50 pm - 10:00 pm	M	BECKETT, A	FH B27
3224	LEC	6:50 pm - 10:00 pm	T	ROBINSON NEARY,	FH 212
3226	LEC	- 3:10 hrs	TBA	O CONNELL, E D	ON LINE
3228	LEC	6:50 pm - 10:00 pm	W	CAVE, T	FH B09
3229	LEC	6:50 pm - 10:00 pm	Th	SCHWARTZ, B R	FH 225
3463	LEC	3:30 pm - 4:55 pm	T Th	GIARELLI, J A	FH B27
3699	LEC	6:50 pm - 10:10 pm	M W	NISHIMURA, J M	HH 107
<i>(8 Week Class - Starts 10/25/2010, Ends 12/19/2010)</i>					
3703		- 3:10 hrs	TBA	TAMAYO, F	ON LINE
8137	LEC	12:10 pm - 3:20 pm	S	MANILL, L F	FH 303

ENGLISH 102 - COLLEGE READING AND COMPOSITION II (UC:CSU) - 3.00 UNITS

PREREQUISITE: English 101 or equivalent. Students study literature and literary criticism in order to develop critical thinking, reading and writing skills beyond the level achieved in English 101, emphasizing logical reasoning, analysis, and strategies of argumentation.

0261	LEC	9:00 am - 10:25 am	M W	SOTIRIOU, P E	FH 212
0325	LEC	10:35 am - 12:00 pm	T Th	COLOMBO, G J	TBA TBA
0408	LEC	9:00 am - 12:00 pm	S	RAWSON, E S	FH 303
0450	LEC	10:35 am - 12:00 pm	M W	NISHIMURA, J M	FH 303
0466	LEC	1:45 pm - 3:10 pm	T Th	LIPMAN, D N	FH B26
0467	LEC	9:00 am - 10:30 am	M W	MULLER, D N	FH B26
0469	LEC	9:00 am - 12:00 pm	M W	MARDIRUSSIAN, G	FH B24
<i>(8 Week Class - Starts 10/25/2010, Ends 12/19/2010)</i>					
0470	LEC	10:35 am - 12:00 pm	T Th	EISENSTEIN, S A	FH 303
0555		- 3:10 hrs	TBA	TAMAYO, F	ON LINE
3220	LEC	6:50 pm - 10:00 pm	W	IRELAND, S P	FH 212
3231	LEC	6:50 pm - 10:00 pm	T	SALERNO, M	FH 114

SECTION# TIME DAYS INSTRUCTOR LOCATION

ENGLISH 103 - COMPOSITION AND CRITICAL THINKING (UC:CSU) - 3.00 UNITS

PREREQUISITE: English 101 or equivalent. DESCRIPTION: Development of logical, argumentative, and analytical thinking through examination of written and other types of cultural texts.

0448	LEC	1:45 pm - 3:10 pm	T Th	NISHIMURA, J M	FH B12
0471	LEC	9:00 am - 10:25 am	T Th	STAFF	FH 302
0472	LEC	12:10 pm - 1:35 pm	M W	STAFF	FH 205
0473	LEC	10:35 am - 12:00 pm	T Th	KENDALL, E W	FH 205
0474	LEC	9:00 am - 12:00 pm	S	STAFF	FH B26
0475	LEC	9:25 am - 10:50 am	M W	ROBINSON, T R	TBA TBA
0476	LEC	10:35 am - 12:00 pm	M W	EISENSTEIN, S A	FH 205
0477	LEC	9:00 am - 12:20 pm	M W	STAFF	CHEM 201
<i>(8 Week Class - Starts 10/25/2010, Ends 12/19/2010)</i>					
0556	LEC	- 3:10 hrs	TBA	PATTHEY, G G	ON LINE
1355	LEC	- 3:10 hrs	TBA	KENDALL, E W	ON LINE
3232	LEC	6:50 pm - 10:00 pm	T Th	MAECK, A T	FH B02
<i>(8 Week Class - Starts 10/25/2010, Ends 12/19/2010)</i>					
3233	LEC	3:30 pm - 6:40 pm	W	STAFF	FH 212
3237	LEC	6:50 pm - 10:00 pm	W	BELIKIAN, L	FH B26

ENGLISH 108 - WRITING WORKSHOP - 0.50 UNITS Rpt 3

English 108 is a supplemental laboratory course for students enrolled in English 101, 102, or 103. Students receive additional instruction in writing college-level essays. Research techniques, proper citation, and strategies in organizing, supporting and revising written assignments are reviewed.

0145	LAB	- 0:50 hrs	TBA	LEVIN, R B	AD 318
0310	LAB	- 1:05 hrs	TBA	STAFF	AD 318
1603	LAB	- 0:50 hrs	TBA	STAFF	AD 318
1608	LAB	- 0:55 hrs	TBA	STAFF	AD 318

ENGLISH 127 - CREATIVE WRITING (UC:CSU) - 3.00 UNITS Rpt 3

PREREQUISITE: English 101 or equivalent. DESCRIPTION: This course offers blocks of intensive training in writing poetry, prose fiction, and/or playwrighting. Discussion of each participant's writing is the central mode of instruction, supplemented by examples of published writers and theoretical essays on the creative process.

0129	LEC	1:45 pm - 5:05 pm	Th	EISENSTEIN, S A	FH 303
------	-----	-------------------	----	-----------------	--------

ENGLISH 203 - WORLD LITERATURE I (UC:CSU) - 3.00 UNITS

PREREQUISITE: English 101 or equivalent. DESCRIPTION: Study of selected major works of Western and Far Eastern literature from antiquity to the 17th century.

1335	LEC	10:35 am - 12:00 pm	T Th	MULLER, D N	FH 114
------	-----	---------------------	------	-------------	--------

ENGLISH 205 - ENGLISH LITERATURE I (UC:CSU) - 3.00 UNITS

Prerequisite: English 102 or equivalent. Students read, discuss and analyze major works of English literature from the beginnings to the nineteenth century, to develop an understanding and appreciation of the poetry, fiction, and drama of these literary periods and to express that appreciation in reasoned analyses.

0478	LEC	10:35 am - 12:00 pm	M W	SOTIRIOU, P E	FH B26
------	-----	---------------------	-----	---------------	--------

ENGLISH 211 - FICTION (UC:CSU) - 3.00 UNITS Rpt 1

PREREQUISITE: English 101 with a satisfactory grade or better. Students read, discuss, and analyze selected short stories and novels written in, or translated into, English from a diversity of cultures and countries to increase students' understanding and appreciation of the art and craft of fiction writing.

0263		- 3:10 hrs	TBA	PATTHEY, G G	ON LINE
------	--	------------	-----	--------------	---------

ENGLISH 212 - POETRY (UC:CSU) - 3.00 UNITS Rpt 1

PREREQUISITE: English 101 or equivalent. Students study works by selected poets and background for appreciation of the poetic form, including early verses to 20th and 21st centuries' poetry.

0209	LEC	9:00 am - 10:25 am	T Th	KENDALL, E W	FH B27
------	-----	--------------------	------	--------------	--------

SECTION# TIME DAYS INSTRUCTOR LOCATION

ENGLISH 240 - LITERATURE AND THE MOTION PICTURE I (UC:CSU) - 3.00 UNITS

PREREQUISITE: English 101 or equivalent. DESCRIPTION: This course gives students opportunities to analyze and evaluate films of artistic and cultural significance. The language, structure, and narrative techniques of film and literary classics will be compared by reading literature and watching films based on these literary sources.

3047 LEC 6:50 pm -10:00 pm T RYAN, J M FH B12

ENGLISH 270 - SCIENCE FICTION - FANTASY (UC:CSU) - 3.00 UNITS

PREREQUISITE: English 101 or equivalent. Students read and study works of science fiction, with an emphasis on the use of mythology, science fiction by scientists and non-scientists, philosophically oriented science fiction, and science fiction as fantasy and escape literature.

3239 LEC - 3:10 hrs TBA BORETZ, M S ON LINE

ENGLISH 285 - DIRECTED STUDY - ENGLISH (CSU) - 2.00 UNITS

Students pursue directed study in literary analysis, a particular genre or period, or independent research on a contract basis under the direction of a supervising instructor.

8143 - 2:05 hrs TBA ROBINSON, T R AD 318

ENGLISH 385 - DIRECTED STUDY - ENGLISH (CSU) - 3.00 UNITS

PREREQUISITE: Approval of proposed project.

8142 - 3:10 hrs TBA ROBINSON, T R AD 318

ENGLISH AS A SECOND LANGUAGE

Chair: Tammy Robinson, SCI324N (323) 953-4000 ext 2700
<http://catalog.lacitycollege.edu/pages/english.html>

ENGLISH AS A SECOND LANGUAGE 002A - COLLEGE ENGLISH AS A SECOND LANGUAGE II: WRITING AND GRAMMAR (NDA) - 6.00 UNITS

PREREQUISITE: Successful completion of ESL 1A or appropriate placement score. ADVISORY: Concurrent enrollment in ESL 2B. (Credit/No Credit)

0508 LEC 8:55 am -12:05 pm M W LAPP, R E CCW 233
0509 LEC 8:55 am -12:05 pm T Th STAFF CCW 256
0513 LEC 9:30 am - 4:00 pm S STAFF CCW 243
1354 LEC 1:45 pm - 4:55 pm M W STAFF CCW 233
3250 LEC 6:50 pm -10:00 pm T Th STAFF CCW 233
3251 LEC 6:50 pm -10:00 pm M W SOTO, C L CCW 233

ENGLISH AS A SECOND LANGUAGE 002B - COLLEGE ENGLISH AS A SECOND LANGUAGE II: LISTENING AND SPEAKING (NDA) - 6.00 UNITS

PREREQUISITE: Successful completion of ESL 1B or appropriate placement score. ADVISORY: Concurrent enrollment in ESL 2A. (Credit/No Credit)

0510 LEC 8:55 am -12:05 pm T Th POURTAVASOLI, H CCW 238
0512 LEC 8:55 am -12:05 pm M W FARAHMAND, A CCW 235
0515 LEC 1:45 pm - 4:55 pm T Th STAFF CCW 238
3252 LEC 6:50 pm -10:00 pm M W WARNER, D J CCW 243
3253 LEC 6:50 pm -10:00 pm T Th TCHEN, B W CCW 243

ENGLISH AS A SECOND LANGUAGE 003A - COLLEGE ENGLISH AS A SECOND LANGUAGE III: WRITING AND GRAMMAR - 6.00 UNITS

PREREQUISITE: Successful completion of ESL 2A or appropriate placement score. ADVISORY: Concurrent enrollment in ESL 3B and ESL 3C. (Credit/No Credit) Students at the low-intermediate ESL level learn skills in writing and grammar to prepare them for college work.

0514 LEC 8:55 am -12:05 pm M W RYAN, J M CCW 247
0516 LEC 9:30 am - 4:00 pm S STAFF CCW 236
0517 LEC 8:55 am -12:05 pm T Th STAFF CCW 247
0523 LEC 12:10 pm - 3:20 pm M W WILLIAMS, B S CCW 235
3255 LEC 6:50 pm -10:00 pm M W PATTHEY, G G CCW 235
3256 LEC 6:50 pm -10:00 pm T Th STAFF CCW 236

SECTION# TIME DAYS INSTRUCTOR LOCATION

ENGLISH AS A SECOND LANGUAGE 003B - COLLEGE ENGLISH AS A SECOND LANGUAGE III: READING AND VOCABULARY - 3.00 UNITS

PREREQUISITES: ESL 2B or Appropriate Score on the English Placement Exam. ADVISORIES: ESL 3A and ESL 3C. (Credit/No Credit) Students at the low intermediate ESL level receive instruction in reading and vocabulary skills to prepare them for college work.

0519 LEC 1:45 pm - 3:10 pm T Th STAFF CCW 233
0520 LEC 10:35 am -12:00 pm M W STAFF CCW 236
0521 LEC 10:35 am -12:00 pm T Th STAFF CCW 234
3259 LEC 6:50 pm -10:00 pm T KIM, P M CCW 247
3276 LEC 6:50 pm -10:00 pm W LAPP, R E CCW 247

ENGLISH AS A SECOND LANGUAGE 003C - COLLEGE ENGLISH AS A SECOND LANGUAGE III: LISTENING AND SPEAKING - 3.00 UNITS

PREREQUISITE: Successful completion of ESL 2B or appropriate placement score. ADVISORY: Concurrent enrollment in ESL 3A and ESL 3B. (Credit/No Credit).

0522 LEC 12:10 pm - 1:35 pm M W STAFF CCW 236
0563 LEC 1:45 pm - 3:10 pm T Th STAFF CCW 247
3262 LEC 6:50 pm -10:00 pm M STAFF CCW 247
3263 LEC 6:50 pm -10:00 pm Th STAFF CCW 247

ENGLISH AS A SECOND LANGUAGE 004A - COLLEGE ENGLISH AS A SECOND LANGUAGE IV: WRITING AND GRAMMAR - 6.00 UNITS

Prerequisite: Successful completion of ESL 3A or appropriate placement score. Advisory: ESL 4B and Speech 71 (see the Speech section for more information.) (Credit/No Credit) Students at the high-intermediate ESL level learn skills in writing and grammar to prepare them for college work.

0229 LEC 12:10 pm - 3:20 pm T Th MARDIRUSSIAN, G FH 221
0534 LEC 12:10 pm - 3:20 pm M W NIEMEYER, S L FH 303
0536 LEC 8:55 am -12:05 pm M W HARRIS, F FH 114
0537 LEC 8:55 am -12:05 pm T Th TCHEN, B W CCW 243
0538 LEC 9:30 am - 4:00 pm S PATTHEY, G G FH 212
3275 LEC 6:50 pm -10:00 pm M W MAECK, A T FH 205
3278 LEC 6:50 pm -10:00 pm T Th STAFF FH 303

ENGLISH AS A SECOND LANGUAGE 004B - COLLEGE ENGLISH AS A SECOND LANGUAGE IV: READING AND VOCABULARY - 3.00 UNITS

Prerequisite: Successful completion of ESL 3B or appropriate placement score. Advisory: Concurrent enrollment in ESL 4A. (Credit/No Credit)

0541 LEC 10:35 am -12:00 pm M W NIEMEYER, S L FH B24
0542 LEC 12:10 pm - 3:20 pm W GORDON, E M FH B26
0553 LEC 1:45 pm - 3:10 pm T Th STAFF FH B24
3240 LEC 6:50 pm -10:00 pm M TCHEN, B W FH 212
3279 LEC 6:50 pm -10:00 pm Th STAFF FH B24

ENGLISH AS A SECOND LANGUAGE 005A - COLLEGE ENGLISH AS A SECOND LANGUAGE V: WRITING AND GRAMMAR (CSU) - 6.00 UNITS

Prerequisite: Successful completion of ESL 4A or appropriate placement score. Advisory: Concurrent enrollment in ESL 5B and Speech 72 (see the Speech section for more information).

0322 LEC 8:55 am -12:05 pm T Th RYAN, J M FH 221
0543 LEC 12:10 pm - 3:20 pm M W MARDIRUSSIAN, G FH 114
0544 LEC 8:55 am -12:05 pm M W BERNARD, G R FH B02
0545 LEC 8:55 am -12:05 pm T Th LAPP, R E FH 114
0546 LEC 12:10 pm - 3:20 pm T Th STAFF FH 114
3242 LEC 6:50 pm -10:00 pm T Th STAFF HH 106
3281 LEC 6:50 pm -10:00 pm M W STAFF FH B04
8144 LEC 9:30 am - 4:00 pm S STAFF FH 305

ESL COURSE SEQUENCE

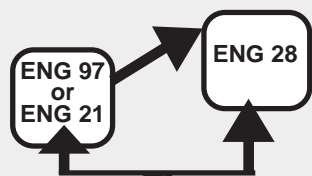

Students who receive credit in ESL 6A may register for English 21 or 28

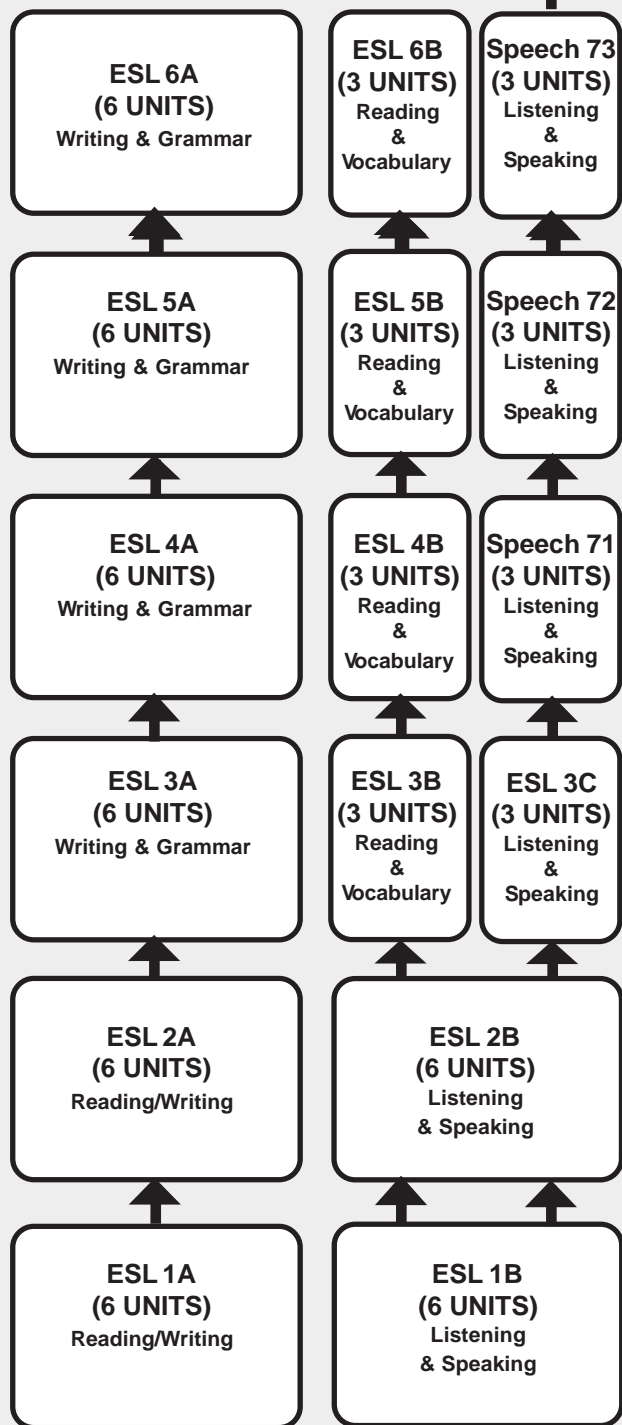

ENGLISH AS A SECOND LANGUAGE 005B - COLLEGE ENGLISH AS A SECOND LANGUAGE V: READING AND VOCABULARY - 3.00 UNITS

PREREQUISITE: Successful completion of ESL 4B or appropriate placement score. ADVISORY: Concurrent enrollment in ESL 5A and Speech 72 (see the Speech section for more information.)

0323	LEC	8:55 am - 10:20 am	M W	COLOMBO, G J	FH 223
0526	LEC	12:10 pm - 1:35 pm	M W	STAFF	FH 212
0134	LEC	12:10 pm - 1:40 pm	T Th	NIEMEYER, S L	FH 223
3283	LEC	6:50 pm -10:00 pm	T	STAFF	HH 102
3284	LEC	6:50 pm -10:00 pm	W	STAFF	FH B27

ENGLISH AS A SECOND LANGUAGE 006A - COLLEGE ENGLISH AS A SECOND LANGUAGE VI: WRITING AND GRAMMAR (CSU) - 6.00 UNITS

Prerequisite: Successful completion of ESL 5A or appropriate placement score. Advisory: Concurrent enrollment in ESL 6B and Speech 73 (see the Speech section for more information).

0549	LEC	12:10 pm - 3:30 pm	M W	STAFF	HH 102
0550	LEC	12:10 pm - 3:20 pm	T Th	GORDON, E M	FH 212
Special tutorial assistance available to students in section 0550.					
0551	LEC	8:55 am - 12:05 pm	T Th	BERNARD, G R	FH 225
3286	LEC	6:50 pm -10:00 pm	M W	STAFF	HH 106
3287	LEC	6:50 pm -10:00 pm	T Th	SMITH, R A	FH 205

ENGLISH AS A SECOND LANGUAGE 006B - COLLEGE ENGLISH AS A SECOND LANGUAGE VI: READING AND VOCABULARY - 3.00 UNITS

Prerequisite: Successful completion of ESL 5B or appropriate placement score. Advisory: Concurrent enrollment in ESL 6A. Students at the high-advanced ESL level learn skills in reading and vocabulary to prepare them for college work.

0137	LEC	10:35 am - 12:05 pm	T Th	NIEMEYER, S L	FH 302
3289	LEC	6:50 pm -10:00 pm	W	RYAN, J M	FH 223

FAMILY AND CONSUMER STUDIES

Chair: Kathleen Bimber, CDB202 (323) 953-4000 ext 2290

Vice Chair: Janice Young, ext 2291

<http://www.lacitycollege.edu/academic/departments/dietetics/index.html>

FAMILY AND CONSUMER STUDIES 021 - NUTRITION (UC:CSU) - 3.00 UNITS

CO-REQUISITE: English 21 and 67 or equivalent. Students learn the scientific concepts of Nutrition in a lecture interactive format evaluating how lifestyle, diet, food/nutrition/nutrient excess and deficiencies; phytochemicals; food safety; food technology affect diseases and assessment of nutrition in human development from conception through maturity. Personal dietary assessment, synthesizing data from computerized dietary program and family tree, appraises nutritional disease risk factors. Students evaluate excesses and deficiencies and construct practices that establish and maintain a healthy lifestyle and result in a healthier mind, healthier nutritional eating practices, enhancing the spirit and nourishing the body.

0564		- 3:10 hrs	TBA	STAFSKY, G B	ON LINE
0565	LEC	9:00 am - 12:10 pm	T	STAFSKY, G B	CD 215
3291	LEC	3:30 pm - 6:40 pm	T	STAFSKY, G B	AD 204
3293	LEC	6:50 pm -10:00 pm	M	MONTOYA, M K	AD 204

FAMILY AND CONSUMER STUDIES 027 - NUTRITION CARE (CSU) - 3.00 UNITS

PREREQUISITE: F&CS 21, 55, 56. CO-REQUISITE: Concurrent enrollment in F&CS 127 required. ADVISORY: English 101 or equivalent, Biology 25 or Anatomy 1; Enrollment subject to confirmation of prerequisites. DESCRIPTION: Nutrition problems of patients with cancer, AIDS, heart disease, diabetes, gastrointestinal diseases, renal diseases, and liver diseases are studied for appropriate menu modifications. The development and implementation of nutrition care plans is emphasized.

0567	LEC	7:00 am - 10:10 am	W	YOUNG, J J	AD 204
------	-----	--------------------	---	------------	--------

SECTION# TIME DAYS INSTRUCTOR LOCATION

FAMILY AND CONSUMER STUDIES 031 - MARRIAGE AND FAMILY LIFE (UC:CSU) - 3.00 UNITS

PREREQUISITE: English 21 or English 73 or equivalent. DESCRIPTION: Interpersonal growth and development are explored over the course of the family life cycle. Examines the impact of social, psychological and economic forces that affect the family.

3292 LEC 6:50 pm -10:00 pm T KENNEDY, S S AD 204

FAMILY AND CONSUMER STUDIES 050 - SANITATION AND SAFETY (CSU) - 3.00 UNITS

CO-REQUISITE: English 21 or equivalent. Students learn basic principles of sanitation and safety including the types of microorganisms that cause foodborne illness, foodborne infections, toxin-mediated infection, and intoxication. Class includes discussion of environmental conditions including food hazards, contamination, cross-contamination, time and temperature, and personal food handler practices that cause sanitation/safety risks. US Food Code regulations, California state and Los Angeles County Environmental Health Department regulations and a HACCP system of food safety will help define the role of food, people, and facility in managing a sanitary food facility operation. Emphasis on the importance of proper employee food safety training practices as related to the providing of safe food are core competencies of this class.

3294 LEC 6:50 pm -10:00 pm Th MONTOYA, M K AD 204

FAMILY AND CONSUMER STUDIES 051 - FOOD PRODUCTION MANAGEMENT (CSU) - 3.00 UNITS

CO-REQUISITE: F&CS 151. ADVISORY: Mathematics 105 or Learning Skills 10ABC or higher and English 21 or 73. DESCRIPTION: Introduction to institutional menu analysis for food requisitioning, food production planning and implementation. Basic principles of quantity cooking are emphasized.

0570 LEC 12:15 pm - 3:25 pm T YOUNG, J J AD 204

FAMILY AND CONSUMER STUDIES 055 - DIETETIC EDUCATION (CSU) - 3.00 UNITS

ADVISORY: English 21 or 73 or equivalent or higher. DESCRIPTION: An introduction to careers in dietetics and school food service. The application of communication skills to training, counseling, and education is studied.

3295 LEC 3:30 pm - 6:40 pm M YOUNG, J J AD 204

FAMILY AND CONSUMER STUDIES 127 - NUTRITION CARE LABORATORY - 2.00 UNITS

PREREQUISITE: Physical examination, negative TB test within the past 6 months, student liability insurance, and background check as required by the Department of Health Services. COREQUISITE: Family and Consumer Science 27. In this clinical laboratory setting, students receive supervised practice in the development and implementation of nutrition care plans in acute care facilities.

0571 LAB - 6:30 hrs TBA YOUNG, J J AD 202

FAMILY AND CONSUMER STUDIES 151 - FOOD PRODUCTION MANAGEMENT LABORATORY - 2.00 UNITS

PREREQUISITE: Physical examination and negative TB test within the past 6 months, student liability insurance, and background check as required by the Department of Health Services. COREQUISITE: Family and Consumer Science 51 Students receive supervised practice in food requisitioning, food production planning, and quantity food production in a clinical laboratory.

0572 LAB 6:45 am -12:05 pm T YOUNG, J J AD 202

FINANCE

Chair: Thelma Day, AD304 (323) 953-4000 ext. 2900
<http://www.lacitycollege.edu/academic/departments/busad/index.html>

FINANCE 002 - INVESTMENTS (CSU) - 3.00 UNITS

ADVISORY: English 28 or equivalent. DESCRIPTION: The principles of investment, the various types of investments, the operations of investment markets, and sources of information.

1323 LEC 10:35 am -12:00 pm M W MARTINI, M A AD 303

SECTION# TIME DAYS INSTRUCTOR LOCATION

FINANCE 008 - PERSONAL FINANCE AND INVESTMENTS (CSU) - 3.00 UNITS

ADVISORY: English 28 or equivalent. DESCRIPTION: Applying the principles of accounting, banking, finance, office methods, management, and production, to one's personal affairs.

3305 LEC - 3:10 hrs TBA ALMURDAAH, A Z ON LINE
almurdaah@lacitycollege.edu

FINANCE 015 - PRINCIPLES OF BANKING (CSU) - 3.00 UNITS

ADVISORY: English 28 or equivalent. Students learn to interpret physical maps, including weather maps and topographic maps, as well as perform hands-on exercises that explore Earth-Sun relationships, atmospheric temperature, pressure and moisture, climate and biomes, plate tectonics and volcanoes, and landforms.

3006 LEC 6:50 pm -10:00 pm M BEIDLEMAN, E V AD 303

FRENCH

Chair: Eiko K. Chatel, DH312B (323) 953-4000 ext. 2737
<http://www.lacitycollege.edu/academic/departments/forlang/index.html>

FRENCH 001 - ELEMENTARY FRENCH I (UC:CSU) - 5.00 UNITS

ADVISORY: English 28 and 67. Credit allowed for either French 1, OR French 21 and 22 together. The student learns French pronunciation and grammar, practical vocabulary, useful phrases as well as basic facts on the geography, customs and culture of the French speaking world.

0587 LEC 7:25 am - 8:35 am MTWTh GUIRGUIS, M R DH 305
AND LAB - 1:05 hrs TBA STAFF DH 319
3311 LEC 5:15 pm - 6:25 pm MTWTh ROZENKOPF, F DH 305
AND LEC - 1:05 hrs TBA STAFF DH 319
3312 LEC 6:50 pm - 9:20 pm T Th BEDDAWI, A J DH 307
AND LAB - 1:05 hrs TBA STAFF DH 319

FRENCH 002 - ELEMENTARY FRENCH II (UC:CSU) - 5.00 UNITS

PREREQUISITE: French 1 with a satisfactory grade or equivalent. DESCRIPTION: Class meets 6 hours; 5 hours lecture and 1 hour TBA in the Language Lab, DH 319.

0590 LEC 9:00 am - 10:10 am MTWTh GUIRGUIS, M R DH 305
3314 LEC 6:50 pm - 9:20 pm T Th ROZENKOPF, F DH 305

FRENCH 003 - INTERMEDIATE FRENCH I (UC:CSU) - 5.00 UNITS

PREREQUISITE: French 2 with a satisfactory grade or equivalent. DESCRIPTION: Class meets 6 hours; 5 hours lecture and 1 hour TBA in the Language Lab, DH 319.

3044 LEC 6:50 pm - 9:25 pm M W ROZENKOPF, F DH 305
AND LAB - 1:00 hrs TBA STAFF DH 319

FRENCH 008 - CONVERSATIONAL FRENCH (UC:CSU) - 2.00 UNITS Rpt 3

PREREQUISITE: French 2 with a satisfactory grade or equivalent. NOTE: Class assignments will require one hour per week in French 30, the Foreign Language Laboratory - DH 319.

0205 LEC 3:30 pm - 4:30 pm M W ROZENKOPF, F DH 305

FRENCH 010 - FRENCH CIVILIZATION (UC:CSU) - 3.00 UNITS

ADVISORY: English 28 and 67 Students learn about French culture from before the Romans through the culture of today. The ruling dynasties, various wars and revolutions and their affect on the arts and literature is discussed. Students assess the role of France in Europe and the world.

0206 LEC 1:45 pm - 3:10 pm M W ROZENKOPF, F DH 305

GEOGRAPHY

Chair: John Freitas, SCI324B (323) 953-4000 ext 2600
<http://www.lacitycollege.edu/academic/departments/chemistry/>

GEOGRAPHY 001 - PHYSICAL GEOGRAPHY (UC:CSU) - 3.00 UNITS

ADVISORY: English 28 and 67 or its equivalent. Students learn about basic scientific principles of geography such as Earth-Sun relationships, weather and climate,

SECTION#	TIME	DAYS	INSTRUCTOR	LOCATION	
ecosystems and biomes, anthropogenic pollution and climate change, Earth's internal structure and processes, and surface topography. Students will also learn basic map reading and geographic literacy.					
0598	LEC	9:00 am - 12:10 pm	S	LONGO, A J	SCI 204
0601	LEC	10:35 am - 12:00 pm	M W	FARRELL, M J	SCI 204
0602	LEC	10:35 am - 12:00 pm	T Th	HURST, T A	SCI 204
3319	LEC	5:15 pm - 6:40 pm	T Th	FARRELL, M J	SCI 130

GEOGRAPHY 002 - CULTURAL ELEMENTS OF GEOGRAPHY (UC:CSU) - 3.00 UNITS

ADVISORY: English 28 and 67 or equivalent. Students learn about human cultural variables in the context of the globe, including the description, analysis, and explanation of population, migration, folk and popular culture, language, religion, ethnicity, political geography, development, agriculture, industry, economic activities, urban areas, and resource utilization. Special emphasis is placed on contemporary issues such as the effects of globalization and the impact of human settlements on the natural environment. Students also learn basic geographic literacy and map reading.

1598	LEC	9:00 am - 10:25 am	M W	FARRELL, M J	SCI 204
3321	LEC	6:50 pm - 10:00 pm	W	CONTI, M R	SCI 204

GEOGRAPHY 015 - PHYSICAL GEOGRAPHY LABORATORY (UC:CSU) - 2.00 UNITS

Advisories: English 28 and 67 and Geography 1. Students learn to interpret physical maps, including weather maps and topographic maps, as well as perform hands-on exercises that explore Earth-Sun relationships, atmospheric temperature, pressure and moisture, climate and biomes, plate tectonics and volcanoes, and landforms.

0603	LEC	12:10 pm - 1:15 pm	M	FARRELL, M J	SCI 204
AND	LAB	1:15 pm - 3:20 pm	M	FARRELL, M J	SCI 204
0605	LEC	1:45 pm - 2:50 pm	T	FARRELL, M J	SCI 204
AND	LAB	2:50 pm - 4:55 pm	T	FARRELL, M J	SCI 204
3320	LEC	6:50 pm - 7:55 pm	Th	FARRELL, M J	SCI 204
AND	LAB	7:55 pm - 10:00 pm	Th	FARRELL, M J	SCI 204

GEOLOGY

Chair: John Freitas, SCI324B (323) 953-4000 ext 2600
<http://www.lacitycollege.edu/academic/departments/chemistry/>

GEOLOGY 001 - PHYSICAL GEOLOGY (UC:CSU) - 3.00 UNITS

ADVISORIES In this is an elementary course the student receives a general introduction to the study of earth's rocks, landforms, oceans, natural resources, and alternative energy resources.

0609	LEC	12:10 pm - 3:20 pm	M	O' BOYLE, C L	SCI 200
0610	LEC	10:35 am - 12:00 pm	M W	O' BOYLE, C L	SCI 200
3324	LEC	5:15 pm - 6:40 pm	T Th	O' BOYLE, C L	SCI 200

GEOLOGY 006 - PHYSICAL GEOLOGY LABORATORY (UC:CSU) - 2.00 UNITS

Advisories: English 28 and 67; Geology 1. In this course the student learns to identify minerals and rocks, as well as the development and interpretation of topographic maps.

0611	LEC	12:10 pm - 1:15 pm	W	O' BOYLE, C L	SCI 200
AND	LAB	1:15 pm - 3:20 pm	W	O' BOYLE, C L	SCI 200
3325	LEC	6:50 pm - 7:50 pm	Th	O' BOYLE, C L	SCI 200
AND	LAB	7:50 pm - 10:00 pm	Th	O' BOYLE, C L	SCI 200

HEALTH

Chair: John Erdhaus, MG104 (323) 953-4000 ext 2851
<http://www.lacitycollege.edu/academic/departments/health/index/html>

HEALTH 002 - HEALTH AND FITNESS (UC:CSU) - 3.00 UNITS

DESCRIPTION: Course explores physical fitness as related to cardiovascular capacity, nutrition, stress, and addictive substances.

0193	LEC	- 2:00 hrs	TBA	CAIRNS, N J	ON LINE
AND	LAB	11:00 am - 12:00 pm	M W	CAIRNS, N J	MG 108
0195	LEC	- 2:15 hrs	TBA	CAIRNS, N J	ON LINE
AND	LAB	12:10 pm - 1:10 pm	M W	CAIRNS, N J	MG 108

SECTION#	TIME	DAYS	INSTRUCTOR	LOCATION	
0621	LEC	6:25 am - 7:25 am	M W	COWGILL, D P	MG 201
AND	LAB	- 1:00 hrs	TBA	COWGILL, D P	MG 201
0622	LEC	6:25 am - 7:25 am	T Th	ROUSEY, S M	MG 201
AND	LAB	- 2:10 hrs	TBA	ROUSEY, S M	MG 201
0623	LEC	7:50 am - 8:50 am	M W	ROUSEY, S M	MG 201
AND	LAB	- 2:10 hrs	TBA	ROUSEY, S M	MG 201
0624	LEC	7:50 am - 8:50 am	T Th	COWGILL, D P	MG 201
AND	LAB	- 2:10 hrs	TBA	COWGILL, D P	MG 201
0625	LEC	9:00 am - 10:00 am	M W	ROUSEY, S M	MG 201
AND	LAB	- 2:10 hrs	TBA	ROUSEY, S M	MG 201
0627	LEC	9:00 am - 10:00 am	T Th	COWGILL, D P	MG 109B
AND	LAB	- 2:00 hrs	TBA	COWGILL, D P	AD 302
0629	LEC	10:35 am - 11:35 am	M W	COWGILL, D P	MG 201
AND	LAB	- 2:10 hrs	TBA	COWGILL, D P	MG 201
0640	LEC	10:35 am - 12:00 pm	T Th	GEVANYAN, A	MG 201
AND	LAB	- 2:05 hrs	TBA	GEVANYAN, A	MG 201

HEALTH 008 - WOMEN'S PERSONAL HEALTH (UC:CSU) - 3.00 UNITS

ADVISORY: English 28/31. DESCRIPTION: The course examines the personal and social dimensions of women's health and the development of strategies for empowerment in decision making that impact changes and improvement in health welfare.

0626	LEC	1:45 pm - 3:10 pm	T Th	GEVANYAN, A	MG 109B
3741	LEC	3:30 pm - 4:55 pm	T Th	GEVANYAN, A	MG 109B

HEALTH 011 - PRINCIPLES OF HEALTHFUL LIVING (UC:CSU) - 3.00 UNITS

DESCRIPTION: Emphasis is on cognitive concepts and strategies of wellness for the individuals personal community, vocational, and leadership roles.

0618	LEC	1:45 pm - 3:10 pm	T Th	CANO, T D	MG 201
0628	LEC	7:25 am - 8:50 am	M W	TINBERG, C	MG 109B
0632	LEC	9:00 am - 10:25 am	M W	NISHIOKA, H H	MG 109B
0633	LEC	10:35 am - 12:00 pm	T Th	NISHIOKA, H H	MG 109B
0634	LEC	9:00 am - 10:25 am	T Th	NISHIOKA, H H	MG 201
0637	LEC	10:35 am - 12:00 pm	M W	NISHIOKA, H H	MG 109B
0638	LEC	1:45 pm - 3:15 pm	M W	CANO, T D	MG 201
0639	LEC	12:10 pm - 1:35 pm	M W	MCEVEETY, J S	JH 104
1328	LEC	9:00 am - 12:10 pm	S	RUSSELL, B P	MG 201
3019	LEC	6:00 pm - 9:35 pm	Th	MCKINLEY, R S	MG 109B
3025	LEC	6:00 pm - 9:20 pm	M	DIETRICH, J E	MG 201
3027	LEC	- 6:30 hrs	TBA	CAIRNS, N J	ON LINE
<i>(8 Week Class - Starts 8/30/2010, Ends 10/22/2010)</i>					
3028	LEC	- 6:30 hrs	TBA	CAIRNS, N J	ON LINE
<i>(8 Week Class - Starts 10/25/2010, Ends 12/19/2010)</i>					
3054	LEC	6:50 pm - 10:00 pm	W	MCKINLEY, R S	MG 109B
3334	LEC	6:50 pm - 10:00 pm	M	RUSSELL, B P	MG 109
3337	LEC	6:50 pm - 10:00 pm	W	CANO, T D	MG 201
3338	LEC	6:50 pm - 10:00 pm	Th	CANO, T D	MG 201

HISTORY

Chair: Wendel Eckford, FH219E (323) 953-4000 ext. 2561
<http://www.lacitycollege.edu/citymain/academic.html#SUBJECT/AREA>

HISTORY 001 - INTRODUCTION TO WESTERN CIVILIZATION I (UC:CSU) - 3.00 UNITS

ADVISORY: English 28 and 67 or equivalent. DESCRIPTION: A study of the main cultural, economic and political trends and events from the rise of civilization in the Near East to the eve of the French Revolution.

3342	LEC	3:30 pm - 6:40 pm	T	STAFF	FH 216
------	-----	-------------------	---	-------	--------

HISTORY 007 - THE WORLD'S GREAT RELIGIONS (UC:CSU) - 3.00 UNITS

0348	LEC	10:35 am - 12:00 pm	T Th	ECKFORD, W V	FH 221
------	-----	---------------------	------	--------------	--------

SECTION# TIME DAYS INSTRUCTOR LOCATION

HISTORY 011 - POLITICAL AND SOCIAL HISTORY OF THE UNITED STATES I (UC:CSU) - 3.00 UNITS

ADVISORIES: English 28 and 67 or equivalent. Students survey the political and social history of the United States from the colonial period through the Civil War and Reconstruction.

Table with 6 columns: Section#, Time, Days, Instructor, Location. Rows include 0215 LEC 9:00 am - 10:25 am T Th STAFF FH 220, 0654 LEC 7:25 am - 8:50 am M W MOON, M C FH 210, 0656 LEC 10:35 am - 12:00 pm M W STAFF FH 210, 0658 LEC 9:00 am - 10:25 am M W ECKFORD, W V FH 210, 0672 LEC 6:50 pm - 10:00 pm M STAFF FH 210, 0675 LEC 7:25 am - 8:50 am T Th MOON, M C FH 210, 3344 LEC 3:30 pm - 6:40 pm M STAFF FH 210

HISTORY 012 - POLITICAL AND SOCIAL HISTORY OF THE UNITED STATES II (UC:CSU) - 3.00 UNITS

ADVISORY: English 28 or equivalent. DESCRIPTION: Meets the State requirements and degree requirements in U.S. History, U.S. Constitution, and California State and Local Government.

Table with 6 columns: Section#, Time, Days, Instructor, Location. Rows include 0660 LEC 1:45 pm - 3:10 pm M W STAFF FH 225, 0663 LEC 10:35 am - 12:00 pm M W STAFF FH 216

HISTORY 013 - THE UNITED STATES IN THE TWENTIETH CENTURY (UC:CSU) - 3.00 UNITS

The student learns the main events, personalities, and themes of the social and political history of the U.S. in the 20th and 21st Centuries by focusing on their overall impact including a discussion of the country's central institutions. The student identifies, discusses and describes the historical importance of the events of the period in question.

Table with 6 columns: Section#, Time, Days, Instructor, Location. Row includes 3347 LEC 3:30 pm - 6:40 pm W STAFF FH 216

HISTORY 086 - INTRODUCTION TO WORLD CIVILIZATION I (CSU) - 3.00 UNITS

DESCRIPTION: Traces the development of interrelationships of the major world civilizations and their cultural traditions and contributions for the earliest times to the era of European expansion to the sixteenth century.

Table with 6 columns: Section#, Time, Days, Instructor, Location. Rows include 0217 LEC 1:45 pm - 3:10 pm T Th STAFF FH 225, 3216 LEC 6:50 pm - 10:00 pm W STAFF FH 218

HUMANITIES
Chair: Eiko K. Chatel, DH312B (323) 953-4000 ext. 2737
<http://www.lacitycollege.edu/academic/departments/forlang/index.html>

HUMANITIES 006 - GREAT PEOPLE, GREAT AGES (UC:CSU) - 3.00 UNITS Rpt 1

ADVISORY: English 28 and 67 Introduction to ideas and methods in the Humanities. Exploration of the way in which individuals and groups create meaning in their lives and in the world around them.

Table with 6 columns: Section#, Time, Days, Instructor, Location. Rows include 0667 LEC 7:25 am - 8:50 am T Th WALZER, A H DH 310, 0668 LEC 9:00 am - 10:25 am T Th WALZER, A H DH 310

HUMANITIES 008 - GREAT WOMEN, GREAT ERAS (UC:CSU) - 3.00 UNITS Rpt 1

ADVISORY: English 28 and 67 Students are introduced to the ideas and methods in gender studies. A wide range of conceptions of gender identities across cultures and historical eras are explored. Various course topics covered include: how women have resisted oppression, how women have found sources of power in family, friends, work and education, how sexuality is constructed across time and place, and how gender relations continue to evolve.

Table with 6 columns: Section#, Time, Days, Instructor, Location. Row includes 0669 LEC 10:35 am - 12:00 pm T Th WALZER, A H DH 310

SECTION# TIME DAYS INSTRUCTOR LOCATION

HUMANITIES 020 - JAPANESE CIVILIZATION (UC:CSU) - 3.00 UNITS

ADVISORY: English 28 and 67 or equivalent. DESCRIPTION: A survey of Japanese civilization: the historical and cultural backgrounds, religion, philosophy, socio-political institutions and art forms.

Table with 6 columns: Section#, Time, Days, Instructor, Location. Row includes 0670 LEC 12:10 pm - 1:35 pm M W CHATEL, E J DH 306

HUMANITIES 030 - THE BEGINNINGS OF CIVILIZATION (UC:CSU) - 3.00 UNITS

ADVISORY: English 28 and 67 or equivalent. DESCRIPTION: Introduction to ancient cultures and world religions. Examination of the foundation texts, art and ideas of various world cultures.

Table with 6 columns: Section#, Time, Days, Instructor, Location. Row includes 0671 LEC 10:35 am - 12:00 pm M W WALZER, A H DH 310

HUMANITIES 031 - PEOPLE IN CONTEMPORARY SOCIETY (UC:CSU) - 3.00 UNITS

ADVISORY: English 28 and 67 or equivalent. DESCRIPTION: A continuing study of world cultural and social development from the Renaissance to the present day.

Table with 6 columns: Section#, Time, Days, Instructor, Location. Row includes 0673 LEC 9:00 am - 10:25 am M W WALZER, A H DH 310

HUMANITIES 045 - KOREAN CIVILIZATION (UC:CSU) - 3.00 UNITS

ADVISORY: English 28 and 67 or equivalent. DESCRIPTION: A survey of Korean civilization: the historical and cultural backgrounds, religion, philosophy, socio-political institution and art forms.

Table with 6 columns: Section#, Time, Days, Instructor, Location. Row includes 0717 LEC 10:35 am - 12:00 pm T Th LEE, J HH 203

HUMANITIES 061 - PEOPLE AND THEIR WORLD: THE CREATIVE PROCESS (UC:CSU) - 3.00 UNITS

ADVISORY: English 28 and 67 or equivalent. DESCRIPTION: A study of contemporary arts, literature, and popular culture. Sections use a range of analytic frameworks, including how the creative process is generated through myth and dreams as well as how race, class, and gender are portrayed in popular culture.

Table with 6 columns: Section#, Time, Days, Instructor, Location. Rows include 3356 LEC 6:50 pm - 10:00 pm Th O CONNELL, C B HH 107, 0223 LEC 12:10pm - 1:40pm MW WALZER, A H DH 310

INTERNATIONAL BUSINESS
Division Chair: Thelma Day, AD304 (323) 953-4000 ext. 2541
<http://www.lacitycollege.edu/academic/departments/busad/index.html>

INTERNATIONAL BUSINESS 001 - INTERNATIONAL TRADE (CSU) - 3.00 UNITS

ADVISORY: Business 1 or equivalent. DESCRIPTION: A study of the principles of international trade, including the basics of operating an import and/or export business. Topics covered include: marketing, terminology, documentation, financial procedures, credits, collections, and communication.

Table with 6 columns: Section#, Time, Days, Instructor, Location. Rows include 3308 LEC - 2:00 hrs TBA HASTEY, R B ON LINE hasteyrb@lacitycollege.edu, AND LEC - 1:05 hrs TBA HASTEY, R B ON LINE

INTERNATIONAL BUSINESS 004 - IMPORT PROCEDURES I (CSU) - 3.00 UNITS

Advisory: International Business 1 with a satisfactory grade or better. The student learns how to identify define, and explain the United States regulatory agencies requirements to import to the United States. Emphasis will be placed on how to determine what duties commodities might be subject to and how to prepare and present to the Bureau of Customs the shipment and its document.

Table with 6 columns: Section#, Time, Days, Instructor, Location. Row includes 0591 LEC - 3:10 hrs TBA DAY, T J ON LINE daytj@lacitycollege.edu

INTERNATIONAL BUSINESS 005 - PAYMENT INSTRUMENTS AND PROCEDURES I - 3.00 UNITS

Advisory: Business 1 or International Business 1 with satisfactory grades or better. The student learns how to arrange and receive payment for merchandise shipped from one

SECTION#	TIME	DAYS	INSTRUCTOR	LOCATION
0592	LEC	- 2:50 hrs	TBA	DAY, T J daytj@lacitycollege.edu

INTERNATIONAL BUSINESS 006 - INTERNATIONAL MARKETING I (CSU) - 3.00 UNITS

DESCRIPTION: Emphasizes how to get foreign customers for American made products, how to identify prospective customers, how to make contact and how to sell the product. Variables include: culture, trade customs, politics, climate, wealth, business and government structures and international law.

3309	LEC	- 2:05 hrs	TBA	HASTEY, R B	ON LINE
AND	LEC	- 1:05 hrs	TBA	HASTEY, R B hasteyrb@lacitycollege.edu	ON LINE

ITALIAN

Division Chair: Eiko K. Chatel, DH312B (323) 953-4000 ext. 2737
<http://www.lacitycollege.edu/academic/departments/forlang/index.html>

ITALIAN 001 - ELEMENTARY ITALIAN I (UC:CSU) - 5.00 UNITS

ADVISORY: English 28 and 67 Pronunciation and grammar, practical vocabulary, useful phrases; basic facts on the geography, customs and culture of the Italian speaking world.

0691	LEC	7:25 am - 8:35 am	MTWTh	SCHERILLO, R	DH 307
AND	LAB	- 1:05 hrs	TBA	STAFF	DH 319

JAPANESE

Chair: Eiko K. Chatel, DH312B (323) 953-4000 ext. 2737
<http://www.lacitycollege.edu/academic/departments/forlang/index.html>

JAPANESE 001 - ELEMENTARY JAPANESE I (UC:CSU) - 5.00 UNITS

ADVISORY: English 28 and 67 Corresponds to the first year of high school Japanese. Fundamentals of pronunciation and grammar, basic vocabulary, useful phrases; reading and writing with Romanized alphabet and Japanese scripts, basic facts on the geography, customs and culture of Japan.

0699	LEC	10:35 am - 11:45 am	MTWTh	TAKEMORI, K	DH 306
AND	LAB	- 1:05 hrs	TBA	STAFF	DH 319
3365	LEC	6:50 pm - 9:20 pm	M W	HASHIBE, M	DH 306
AND	LAB	- 1:05 hrs	TBA	STAFF	DH 319

JAPANESE 002 - ELEMENTARY JAPANESE II (UC:CSU) - 5.00 UNITS

PREREQUISITE: Japanese 1 Completes Elementary Japanese I. Continues to teach fundamentals of pronunciation and grammar. 100 additional Chinese characters will be introduced. Continues to introduce Japanese geography, customs and culture of Japan.

0700	LEC	9:00 am - 10:10 am	MTWTh	FUKUSHIMA, N J	DH 306
AND	LAB	- 1:05 hrs	TBA	STAFF	DH 319
3366	LEC	6:50 pm - 9:20 pm	T Th	FUKUSHIMA, N J	DH 306
AND	LAB	- 1:05 hrs	TBA	STAFF	DH 319

JAPANESE 003 - INTERMEDIATE JAPANESE I (UC:CSU) - 5.00 UNITS

PREREQUISITE: Japanese 2 Continues the study of grammar and vocabulary building for conversational fluency and written composition. Begins the study of short narrative writing.

0222	LEC	7:25 am - 8:35 am	MTWTh	TAKEMORI, K	DH 306
AND	LAB	- 1:00 hrs	TBA	STAFF	DH 319

JAPANESE 008 - ELEMENTARY CONVERSATIONAL JAPANESE (UC:CSU) - 2.00 UNITS Rpt 3

PREREQUISITE: Japanese 2 with a satisfactory grade or equivalent.

0208	LEC	1:45 pm - 3:45 pm	W	CHATEL, E J	DH 306
------	-----	-------------------	---	-------------	--------

SECTION#	TIME	DAYS	INSTRUCTOR	LOCATION
----------	------	------	------------	----------

JOURNALISM

Chair: Daniel Marlos, CHEM BASEMENT (323) 953-4000 ext. 2835
<http://catalog.lacitycollege.edu/pages/journalism.html>

JOURNALISM 101 - COLLECTING AND WRITING NEWS (CSU) - 3.00 UNITS

ADVISORY: English 28. DESCRIPTION: Some typing is required. This introductory course stresses instruction and practice in news gathering and news writing. Extensive practical writing experience is geared to news publications and the news media.

0706	LEC	10:35 am - 12:00 pm	M W	GUESS, R D	BUNG 7C
3368	LEC	6:50 pm - 10:00 pm	M	GUESS, R D	BUNG 7C

JOURNALISM 105 - MASS COMMUNICATIONS (UC:CSU) - 3.00 UNITS

ADVISORY: English 28 and 67 or equivalent. Course provides an examination of America's mass communications systems and how they affect human behavior in relation to social, political and economic institutions. Examines the structure and functioning in print and electronic communications including: film, print, television, radio, the recording industry, public relations and the Internet. Considers factors that influence creation and distribution of media messages, and the impact of those messages on society.

0707	LEC	9:00 am - 10:25 am	M W	BURTON, R	BUNG 7C
------	-----	--------------------	-----	-----------	---------

JOURNALISM 185 - DIRECTED STUDY - JOURNALISM (CSU) - 1.00 UNITS Rpt 2

This course allows journalism students to pursue Directed Study on a contract basis under the direction of a supervising instructor.

8173	LEC	- 1:05 hrs	TBA	GUESS, R D	BUNG 7C
------	-----	------------	-----	------------	---------

JOURNALISM 217 - PUBLICATION LABORATORY (CSU) - 2.00 UNITS Rpt 3

CO-REQUISITE: Concurrent enrollment in Journalism 218. ADVISORY: English 28/31 or equivalent. DESCRIPTION: Laboratory experience for writers, editors and photographers. Stresses hands on application of journalism and photographic skills through production of college newspaper. Desktop editing and publishing techniques will be covered. (Los Angeles Collegian newspaper staff class).

0708	LAB	- 7:25 hrs	TBA	GUESS, R D	BUNG 2B
------	-----	------------	-----	------------	---------

JOURNALISM 218 - PRACTICAL EDITING (CSU) - 3.00 UNITS Rpt 3

PREREQUISITE: Journalism 101 with a satisfactory or better. CO-REQUISITE: Concurrent enrollment in Journalism 217. ADVISORY: English 28/31. DESCRIPTION: Introduction to Macintosh desktop publishing techniques plus an emphasis on practical news writing and editing skills. Designed for students who want to become professional writers, photographers and editors. (Los Angeles Collegian newspaper staff class).

0709	LEC	1:00 pm - 1:30 pm	M W	GUESS, R D	BUNG 2B
AND	LAB	- 7:25 hrs	TBA	GUESS, R D	BUNG 2B

JOURNALISM 219 - TECHNIQUES FOR STAFF EDITORS (CSU) - 1.00 UNITS Rpt 2

PREREQUISITE: Journalism 218. (Los Angeles Collegian editorial board). Required class for all Collegian staff editors. ADVISORY: English 28/31.

0710	LAB	- 3:30 hrs	TBA	GUESS, R D	BUNG 7C
------	-----	------------	-----	------------	---------

JOURNALISM 285 - DIRECTED STUDY - JOURNALISM (CSU) - 2.00 UNITS

This course allows journalism students to the pursue Directed Study on a contract basis under the direction of a supervising instructor.

8174	LEC	- 2:05 hrs	TBA	GUESS, R D	BUNG 7C
------	-----	------------	-----	------------	---------

KOREAN

Chair: Eiko K. Chatel, DH312B (323) 953-4000 ext. 2737
<http://www.lacitycollege.edu/academic/departments/forlang/index.html>

KOREAN 001 - ELEMENTARY KOREAN I (UC:CSU) - 5.00 UNITS

ADVISORY: English 28 and 67 or equivalent. Pronunciation and grammar, practical vocabulary, useful phrases; basic facts on the geography, customs and culture of Korea.

0715	LEC	7:25 am - 8:35 am	MTWTh	HONG, M J	DH 304
AND	LAB	- 1:05 hrs	TBA	STAFF	DH 319
3694	LEC	6:50 pm - 9:40 pm	M W	LEE, J	CCW 236
AND	LAB	- 0:55 hrs	TBA	STAFF	DH 319

KOREAN 002 - ELEMENTARY KOREAN II (UC:CSU) - 5.00 UNITS

PREREQUISITE: Korean 1 with a satisfactory grade or equivalent. ADVISORY: English 28 Completes Elementary Korean I emphasizing reading of elementary texts and spoken language.

1261	LEC	9:00 am - 10:10 am	MTWTh	HONG, M J	DH 304
AND	LAB	- 1:05 hrs	TBA	STAFF	DH 319
3020	LEC	7:00 pm - 9:50 pm	M W	HONG, M J	CCW 242
AND	LAB	- 0:55 hrs	TBA	STAFF	DH 319

KOREAN 004 - INTERMEDIATE KOREAN II (UC:CSU) - 5.00 UNITS

PREREQUISITE: Korean 3 with a satisfactory grade or equivalent. Completes Intermediate Korean I emphasizing reading of intermediate texts and the spoken language.

0127	LEC	10:35 am - 11:45 am	MTWTh	HONG, M J	TBA TBA
------	-----	---------------------	-------	-----------	---------

KOREAN 008 - CONVERSATIONAL KOREAN (UC:CSU) - 2.00 UNITS Rpt 3

Prerequisite: Korean 2 with a satisfactory grade or equivalent. Students will practice practical conversation on everyday topics, current events, and cultural material.

0203	LEC	12:10 pm - 2:15 pm	Th	HONG, M J	DH 308
------	-----	--------------------	----	-----------	--------

KOREAN 010 - KOREAN CIVILIZATION (UC:CSU) - 3.00 UNITS

ADVISORY: English 28 and 67. DESCRIPTION: Open to all students. Lectures and discussions in English.

0191	LEC	10:35 am - 12:00 pm	T Th	LEE, J	HH 203
------	-----	---------------------	------	--------	--------

LAW

Chair: Tim Sweetman, HH12 (323) 953-4000 ext. 2753
Paralegal Coordinator: Dr. Richard Lewis,
HH200D (323) 953-4000 ext 2757
<http://www.lacitycollege.edu/academic/departments/law/index.html>

LAW 001 - BUSINESS LAW I (UC:CSU) - 3.00 UNITS

Students examine the U.S. legal system, focusing on the legal aspects of business; court procedures relating to business law; torts and criminal laws as related to various business practices; elements of a valid contract; breach of contracts and its remedies; sales and lease contracts.

0144		- 3:10 hrs	TBA	LANZER, K C	ON LINE
0225	LEC	9:00 am - 12:10 pm	F	LANZER, K C	HH 205
0729	LEC	10:35 am - 12:00 pm	M W	LEWIS, R P	HH 205
1610		-3:10 hrs	TBA	LEWIS, R P	ON LINE
3035	LEC	3:30 pm - 6:40 pm	T	DUFFY, T E	HH 206
3371	LEC	6:50 pm - 10:00 pm	T	DUFFY, T E	HH 205
3373	LEC	6:50 pm - 10:00 pm	W	DUFFY, T E	HH 205

LAW 002 - BUSINESS LAW II (UC:CSU) - 3.00 UNITS

DESCRIPTION: This course is necessary for a well-rounded knowledge of business rules. Topics include product liability, consumer law, sole proprietorship, partnership, corporation, agency commercial papers, negotiable instruments, drafts, checks, promissory notes, guarantors, co-signers, banking procedures, letters of credit, import and export, bankers' acceptance, bill of lading, warehouse, receipt, secured transactions, insurance, bankruptcy, estates and trusts.

1581	LEC	10:35 am - 12:00 pm	T Th	LEWIS, R P	HH 204
------	-----	---------------------	------	------------	--------

LAW 003 - CIVIL RIGHTS AND THE LAW (UC:CSU) - 3.00 UNITS

The student examines the law and related problems concerning civil rights, due process, freedom of expression, freedom of religion, racial equality, and democratic processes. The emphasis is on recent court decisions and international trends.

3040	LEC	6:50 pm - 10:00 pm	Th	LANZER, K C	HH 203
3730	LEC	3:30 pm - 6:40 pm	M	DUFFY, T E	HH 203

LAW 010 - INTRODUCTION TO LEGAL ASSISTANT I (CSU) - 3.00 UNITS

DESCRIPTION: An introductory course in formalizing the career of the legal assistant. Also an introduction to legal terminology and bibliography, including research problems.

0734	LEC	9:00 am - 10:25 am	T Th	VARGAS, W I	HH 204
3379	LEC	6:50 pm - 10:00 pm	T	LEWIS, R P	HH 204

LAW 011 - INTRODUCTION TO LEGAL ASSISTANT II (CSU) - 3.00 UNITS

PREREQUISITE: Completion of Law 10. Advisory: English 101.

3683	LEC	6:50 pm - 10:00 pm	M	VARGAS, W I	HH 203
-------------	------------	---------------------------	----------	--------------------	---------------

LAW 012 - TORT LAW AND CLAIMS INVESTIGATION (CSU) - 3.00 UNITS

PREREQUISITE: Law 10 and English 101. DESCRIPTION: This course will provide an introduction to the broad area of civil wrongs and their appropriate remedies as well as Tort Law principles in the traditional areas of international torts, negligence, strict liability, nuisance, and the commonly employed defences.

3009	LEC	6:50 pm - 10:00 pm	W	LANZER, K C	HH 203
-------------	------------	---------------------------	----------	--------------------	---------------

LAW 013 - WILLS, TRUSTS, AND PROBATE ADMINISTRATION (CSU) - 3.00 UNITS

PREREQUISITE: Law 10 with satisfactory grades or equivalent. This course will provide a study of the fundamental principles of the law of wills and trusts, including simple will and trust forms and formation; an examination of the organization and jurisdiction of the California Probate Court, with an overview of the administration of estates in probate.

0226	LEC	9:00 am - 12:10 pm	S	VARGAS, W I	HH 203
------	-----	--------------------	---	-------------	--------

LAW 033 - LAW AND THE MEDIA (CSU) - 3.00 UNITS

The student examines the federal, state, and local laws that most directly affect mass communication in the United States, focusing on: a basic understanding of the American legal system, its institutions, and some of its terminology; a broad understanding of First Amendment principles as they relate to mass communication; and a working knowledge of the laws that directly restrict or enhance information gathering and message dissemination in the mass media, and an understanding of the rationales behind those laws.

3380	LEC	3:30 pm - 6:40 pm	T	LEWIS, R P	HH 204
------	-----	-------------------	---	------------	--------

LAW 035 - IMMIGRATION LAW FOR PARALEGALS (CSU) - 3.00 UNITS

ADVISORIES: Law 10 and English 101. Students learn the fundamental concepts of immigration law including grounds of exclusion, defenses to deportation, petitions and visa applications. Research and writing are emphasized in the areas of amnesty, naturalization, citizenship, international law, criminal aspects of immigration, and various types of immigration applications.

0227	LEC	12:30 pm - 3:40 pm	S	VARGAS, W I	HH 203
------	-----	--------------------	---	-------------	--------

LAW 037 - BANKRUPTCY AND CREDITOR'S RIGHTS - 3.00 UNITS

DESCRIPTION: The main focus of this course will be on bankruptcy law and procedure. It will cover commencement of a case, preparing schedules, operating and liquidating procedures, adversary matters and litigation in bankruptcy court, debtors' and creditors' rights and obligations, technical terminology, and practical proceedings under Chapter 7, Chapter 13, and to a lesser extent, Chapter 11. Also proceedings under Chapter 9 and 12 will be reviewed. Additionally, the rights of creditors will be explored. This includes secured transactions, consensual and non-consensual liens, UCC transactions, and the unique position of real estate.

3390	LEC	5:15 pm - 6:40 pm	T Th	LANZER, K C	HH 205
-------------	------------	--------------------------	-------------	--------------------	---------------

SECTION# TIME DAYS INSTRUCTOR LOCATION

LAW 038 - CRIMINAL LAW & PROCEDURE - 3.00 UNITS

DESCRIPTION: This course will provide students with an overview of the substantive and procedural rights of the accused. The student will study the nature, purpose, and principles of through appeal. Further, by developing knowledge of the elements of legal documents in a criminal case. Special topics of interest such as plea-bargaining, youthful offender adjudication, extradition and wiretapping will be studied in detail.

3369 LEC 6:50 pm -10:10 pm Th DUFFY, T E HH 205

LEARNING SKILLS

Chair: Maryanne Des Vignes, LIB103C (323) 953-4000 ext 2770
<http://www.lacitycollege.edu/citymain/academic.html#SUBJECT/AREA>

LEARNING SKILLS 001A - READING (NDA) - 1.00 UNITS Rpt 3

DESCRIPTION: Individualized reading instruction for English as a Native Language (ENL) and English as a Second Language (ESL) students from beginning to advanced college level. Students will progress from reading sentences and paragraphs to short selections and excerpts from novels.

5080 LAB - 3:10 hrs TBA ALLEN, J F LRC 103
8179 LAB - 3:10 hrs TBA MATRANGA, S B LRC 103A

LEARNING SKILLS 001B - READING (NDA) - 1.00 UNITS Rpt 3

DESCRIPTION: Individualized reading instruction for English as a Native Language (ENL) and English as a Second Language (ESL) students from beginning to advanced college level. Students will progress from reading sentences and paragraphs to short selections and excerpts from novels.

5081 LAB - 3:10 hrs TBA KIJEWski, E B LRC 103A

LEARNING SKILLS 001C - READING (NDA) - 1.00 UNITS Rpt 3

DESCRIPTION: Individualized reading instruction for English as a Native Language (ENL) and English as a Second Language (ESL) students from beginning to advanced college level. Students will progress from reading sentences and paragraphs to short selections and excerpts from novels.

0143 LAB - 3:10 hrs TBA DES VIGNES, M LRC 103A

LEARNING SKILLS 002A - ENGLISH FUNDAMENTALS (NDA) - 1.00 UNITS Rpt 3

DESCRIPTION: This course is a review of beginning to advanced grammar. It is designed to cover the basic structure of the sentence, parts of speech, phrases, clauses, and agreement, and verb usage.

8193 LAB - 3:10 hrs TBA ADUNNI, O LRC 103A

LEARNING SKILLS 002B - ENGLISH FUNDAMENTALS (NDA) - 1.00 UNITS Rpt 3

DESCRIPTION: This course is a review of intermediate grammar. It is designed to cover the correct use of pronouns, modifiers and punctuation.

8196 LAB - 3:10 hrs TBA DES VIGNES, M LRC 103A

LEARNING SKILLS 002C - ENGLISH FUNDAMENTALS (NDA) - 1.00 UNITS Rpt 3

DESCRIPTION: This course is a review of advanced grammar. Students will receive instruction in correct pronoun usage, clear reference, placement of modifiers, glossary of usage, and capitalization rules.

8202 LAB - 3:10 hrs TBA ADUNNI, O LRC 103A
8203 LAB - 3:10 hrs TBA DES VIGNES, M LRC 103A

LEARNING SKILLS 003A - VOCABULARY DEVELOPMENT (NDA) - 1.00 UNITS Rpt 3

DESCRIPTION: This course provides instruction in the articulation and pronunciation of English consonants, vowels, and diphthongs to improve English communication skills.

8204 LAB - 3:10 hrs TBA DES VIGNES, M LRC 104C

SECTION# TIME DAYS INSTRUCTOR LOCATION

LEARNING SKILLS 003B - VOCABULARY DEVELOPMENT (NDA) - 1.00 UNITS Rpt 3

DESCRIPTION: This course helps students develop English conversational skills at a beginning level.

8195 LAB - 3:10 hrs TBA DES VIGNES, M LRC 103A

LEARNING SKILLS 003C - VOCABULARY DEVELOPMENT (NDA) - 1.00 UNITS Rpt 3

This course helps the student develop English conversational skills at an intermediate level. Depending upon the diagnostic assessment, students will be placed in an appropriate intermediate conversation program. Students may enroll through the twelfth week of the semester. This course is open to all students. Grades are on a credit/no-credit basis. (RPT3)

8205 LAB - 3:10 hrs TBA DES VIGNES, M PLAT LAB
(16 Week Class - Starts 8/30/2010, Ends 12/19/2010)

LEARNING SKILLS 003D - VOCABULARY DEVELOPMENT (NDA) - 1.00 UNITS Rpt 3

DESCRIPTION: This course helps students develop vocabulary definition and context skills at the beginning, intermediate, and advanced level.

5082 LAB -3:10 hrs TBA ILANO, C B LRC 103A
5083 LAB -3:10 hrs TBA JANNOL, M LRC 103
8206 LAB -3:10 hrs TBA ALLEN, J F LRC 103A
8207 LAB -3:10 hrs TBA KIJEWski, E B LRC 103A

LEARNING SKILLS 003E - VOCABULARY DEVELOPMENT (NDA) - 1.00 UNITS Rpt 3

This course is a review of child development or nutrition vocabulary. Students will receive instruction in the study of human development, theories, heredity and environment, human development, biosocial, cognitive, and psychosocial development/ (nutrition vocabulary) food choices: nutrition tools and standards; the human body and nutrition; carbohydrates, lipids, and proteins; vitamins, water and minerals; energy, balance and body weight; nutrients, physical activity and the body's responses; diet and health; nutrition for the mother and infant; nutrition for the child, the teen, and the older adult; and hunger and the global environment. Depending upon the diagnostic assessment, students will be placed in an appropriate program. Students may enroll through the twelfth week of the semester. This course is open to all students. Grades are based on a credit/no-credit basis. This course is repeatable three times.

8210 LAB - 3:10 hrs TBA ILANO, C B LRC 103A
8211 LAB - 3:10 hrs TBA ALLEN, J F LRC 103A

LEARNING SKILLS 004 - THE MECHANICS OF SPELLING (NDA) - 1.00 UNITS Rpt 3

LS4 is an intensive spelling course designed for non-spellers. Emphasis is placed upon the use of a phonics, focusing on additive doubling, ie or ei, finding silent e, pronunciation aids, tricky endings, words often confused, plurals, capitals, apostrophes, and basic principles. Depending upon the diagnostic assessment, students will be placed in an appropriate program. Students may enroll through the twelfth week of the semester. This course is open to all students. Grades are on a credit/no-credit basis. (RPT3)

8214 LAB - 3:10 hrs TBA ILANO, C B LRC 103A

LEARNING SKILLS 006A - ACADEMIC STUDY SKILLS (NDA) - 1.00 UNITS

This course will introduce students to academic study skills. Students will be introduced to making transitions to higher learning, first steps to self-discovery, time management, discovering how to learn, memorization, and reading. Depending upon the diagnostic assessment, students will be placed in an appropriate study skills program. Students may enroll through the twelfth week of the semester. This course is open to all students. Grades are on a credit/no-credit basis.

5085 LAB - 3:10 hrs TBA JANNOL, M LRC 103A

LEARNING SKILLS 006B - ACADEMIC STUDY SKILLS (NDA) - 1.00 UNITS

This course will introduce students to academic study skills. Students will be introduced to note taking, test-taking strategies, critical thinking, and communicating. Depending upon the diagnostic assessment, students will be placed in an appropriate study skills

SECTION#	TIME	DAYS	INSTRUCTOR	LOCATION
8217	LAB	- 3:10 hrs	TBA	ALLEN, J F LRC 103A

LEARNING SKILLS 006C - ACADEMIC STUDY SKILLS (NDA) - 1.00 UNITS

This course will introduce students to academic study skills. Students will be introduced to diversity, computer technology, health awareness, and career planning. Depending upon the diagnostic assessment, students will be placed in an appropriate study skills program. Students may enroll through the twelfth week of the semester. This course is open to all students. Grades are on a credit/no-credit basis.

8218	LAB	- 3:10 hrs	TBA	ILANO, C B LRC 103A
------	-----	------------	-----	---------------------

LEARNING SKILLS 007A - BASIC COMPOSITION (NDA) - 1.00 UNITS

DESCRIPTION: This course offers beginning writing instruction which focuses on basic sentence structures and paragraph development.

1601	LAB	- 3:10 hrs	TBA	SMITH, A L CH 109
8184	LAB	- 3:10 hrs	TBA	MATRANGA, S B CH 117
8219	LAB	- 3:10 hrs	TBA	ILANO, C B LRC 103A

LEARNING SKILLS 007B - BASIC COMPOSITION (NDA) - 1.00 UNITS

DESCRIPTION: This course offers intermediate writing instruction which focuses on basic sentence structures and three-paragraph essay development.

8187	LAB	- 3:10 hrs	TBA	MATRANGA, S B CH 117
8224	LAB	- 3:10 hrs	TBA	ILANO, C B LRC 103A

LEARNING SKILLS 007C - BASIC COMPOSITION (NDA) - 1.00 UNITS

DESCRIPTION: This course offers advanced writing instruction which focuses upon five-paragraph essay development.

8226	LAB	- 3:10 hrs	TBA	ILANO, C B LRC 103A
------	-----	------------	-----	---------------------

LEARNING SKILLS 010A - MATHEMATICS FUNDAMENTALS (NDA) - 1.00 UNITS Rpt 3

Individualized review of basic mathematics skills involving whole number properties, order of operations, exponents, prime numbers, and fractions. Depending upon the diagnostic assessment, students will be placed in an appropriate program. Students may enroll through the twelfth week of the semester. This course is open to all students. Grades are on a credit/no-credit basis. (RPT3)

8231	LAB	- 3:10 hrs	TBA	VANGOR, R A LRC 103A
8232	LAB	- 3:10 hrs	TBA	ADELEYE, A LRC 103A
8233	LAB	- 3:10 hrs	TBA	DAO, H C LRC 103A
8234	LAB	- 3:10 hrs	TBA	MATRANGA, S B LRC 103A
8235	LAB	- 3:10 hrs	TBA	VANGOR, R A LRC 103A

LEARNING SKILLS 010B - MATHEMATICS FUNDAMENTALS (NDA) - 1.00 UNITS Rpt 3

Individualized review of basic mathematics skills involving fractions and decimals. Depending upon the diagnostic assessment, students will be placed in an appropriate program. Students may enroll through the twelfth week of the semester. This course is open to all students. Grades are on a credit/no-credit basis. (RPT3)

8237	LAB	- 3:10 hrs	TBA	VANGOR, R A LRC 103A
8238	LAB	- 3:10 hrs	TBA	ADELEYE, A LRC 103A

LEARNING SKILLS 010C - MATHEMATICS FUNDAMENTALS (NDA) - 1.00 UNITS Rpt 3

Individualized review of basic mathematics skills involving ratios and proportions, percents, simple geometry, statistical graph analysis, and signed numbers. Depending upon the diagnostic assessment, students will be placed in an appropriate program. Students may enroll through the twelfth week of the semester. This course is open to all students. Grades are on a credit/no-credit basis. (RPT3)

8243	LAB	- 3:10 hrs	TBA	ADELEYE, A LRC 103A
------	-----	------------	-----	---------------------

LEARNING SKILLS 011A - ELEMENTARY ALGEBRA (NDA) - 1.00 UNITS Rpt 3

Individualized review of basic algebra skills involving the language of algebra and equations and inequalities. Students may enroll through the twelfth week of the semester. This course is open to all students. Grades are on a credit/no-credit basis. (RPT3)

8246	LAB	- 3:10 hrs	TBA	DAO, H C LRC 103A
8247	LAB	- 3:10 hrs	TBA	ADELEYE, A LRC 103A
8248	LAB	- 3:10 hrs	TBA	VANGOR, R A LRC 103A

LEARNING SKILLS 011B - ELEMENTARY ALGEBRA (NDA) - 1.00 UNITS Rpt 3

Individualized review of basic algebra skills involving polynomials and factoring. Depending upon the diagnostic assessment, students will be placed in an appropriate program. Students may enroll through the twelfth week of the semester. This course is open to all students. Grades are on a credit/no-credit basis. (RPT3)

8250	LAB	- 3:10 hrs	TBA	ADELEYE, A LRC 103A
8252	LAB	- 3:10 hrs	TBA	VANGOR, R A LRC 103A

LEARNING SKILLS 011C - ELEMENTARY ALGEBRA (NDA) - 1.00 UNITS Rpt 3

Individualized review of basic algebra skills involving rational expressions and graphing. Depending upon the diagnostic assessment, students will be placed in an appropriate program. Students may enroll through the twelfth week of the semester. This course is open to all students. Grades are on a credit/no-credit basis. (RPT3).

8253	LAB	- 3:10 hrs	TBA	ADELEYE, A LRC 103A
8254	LAB	- 3:10 hrs	TBA	VANGOR, R A LRC 103A

LEARNING SKILLS 011D - ELEMENTARY ALGEBRA (NDA) - 1.00 UNITS Rpt 3

Individualized review of basic algebra skills involving graphing and inequalities and linear equations. Depending upon the diagnostic assessment, students will be placed in an appropriate program. Students may enroll through the twelfth week of the semester. This course is open to all students. Grades are on a credit/no-credit basis. (RPT3)

8255	LAB	- 3:10 hrs	TBA	ILANO, C B LRC 103A
8256	LAB	- 3:10 hrs	TBA	ADELEYE, A LRC 103A

LEARNING SKILLS 011E - ELEMENTARY ALGEBRA (NDA) - 1.00 UNITS Rpt 3

Individualized review of basic algebra skills involving exponents and radicals and quadratic equations. Depending upon the diagnostic assessment, students will be placed in an appropriate program. Students may enroll through the twelfth week of the semester. This course is open to all students. Grades are on a credit/no-credit basis. (RPT3)

8257	LAB	- 3:10 hrs	TBA	VANGOR, R A LRC 103A
8258	LAB	- 3:10 hrs	TBA	ADELEYE, A LRC 103A

LEARNING SKILLS 015A - OVERCOMING MATH ANXIETY (NDA) - 1.00 UNITS Rpt 3

This course, LS15A – Overcoming Math Anxiety: Basic Math, is designed to reduce math anxiety and build self-confidence so that math concepts of addition, subtraction, multiplication, division, fractions, decimals, word problems, ratios and proportions and squares/square roots will be comprehensible. A placement test will be given to prescribe an appropriate math module. Depending upon the diagnostic assessment outcome, students will be placed in an appropriate program. Students may enroll through the twelfth week of the semester. This course is open to all students. Grades are on a credit/no-credit basis. (RPT3)

8259	LEC	12:45 pm- 3:35 pm	M	ALLEN, J F LRC 104C
------	-----	-------------------	---	---------------------

(6 Week Class - Starts 9/13/2010, Ends 10/22/2010)

LEARNING SKILLS 015B - OVERCOMING MATH ANXIETY (NDA) - 1.00 UNITS Rpt 3

This course, LS15B – Overcoming Math Anxiety: Beginning Algebra, is designed to reduce math anxiety and build self-confidence so that algebraic concepts of basic algebra, equations and inequalities, linear equations, operations of monomials

SECTION#	TIME	DAYS	INSTRUCTOR	LOCATION
8262	LEC 12:45 pm- 3:35 pm	M	ALLEN, J F	LRC 104C
<i>(6 Week Class - Starts 10/25/2010, Ends 12/10/2010)</i>				

LEARNING SKILLS 015C - OVERCOMING MATH ANXIETY (NDA) - 1.00 UNITS

This course, LS15C – Overcoming Math Anxiety: Intermediate Algebra, is designed to reduce math anxiety and build self-confidence so that algebraic concepts of real numbers, first-degree equations and inequalities, systems of equations and inequalities, polynomials and exponents, rational expressions, rational exponents and radicals, quadratic equations and inequalities, functions and relations, exponential and logarithmic function, sequences and series, and conic sections will be comprehensible. Depending upon the diagnostic assessment outcome, students will be placed in an appropriate program. Students may enroll through the twelfth week of the semester. This course is open to all students. Grades are on a credit/no-credit basis. (RPT3)

8263	LEC	- 3:10 hrs	TBA	ALLEN, J F	CHEM 201
------	-----	------------	-----	------------	----------

LEARNING SKILLS 017A - INDIVIDUALIZED INTERMEDIATE ALGEBRA A (NDA) - 1.00 UNITS Rpt 3

0311	LAB	- 3:10 hrs	TBA	VANGOR, R A	LRC 103A
------	-----	------------	-----	-------------	----------

LEARNING SKILLS 017B - INDIVIDUALIZED INTERMEDIATE ALGEBRA B (NDA) - 1.00 UNITS Rpt 3

0312	LAB	- 3:10 hrs	TBA	VANGOR, R A	LRC 103A
------	-----	------------	-----	-------------	----------

LEARNING SKILLS 017C - INDIVIDUALIZED INTERMEDIATE ALGEBRA C (NDA) - 1.00 UNITS Rpt 3

0313	LAB	- 3:10 hrs	TBA	VANGOR, R A	LRC 103A
------	-----	------------	-----	-------------	----------

LEARNING SKILLS 017D - INDIVIDUALIZED INTERMEDIATE ALGEBRA D (NDA) - 1.00 UNITS Rpt 3

0314	LAB	- 3:10 hrs	TBA	VANGOR, R A	LRC 103A
------	-----	------------	-----	-------------	----------

LEARNING SKILLS 017E - INDIVIDUALIZED INTERMEDIATE ALGEBRA E (NDA) - 1.00 UNITS Rpt 3

0315	LAB	- 3:10 hrs	TBA	VANGOR, R A	LRC 103A
------	-----	------------	-----	-------------	----------

LEARNING SKILLS 024A - THEORY AND PRACTICE OF TUTORING (NDA) - 1.00 UNITS

This course is designed to provide theory and practice in tutoring sessions. Emphasis is placed upon the tutoring process, tutees' academic needs, recordkeeping, and learning styles. Also, tutor training will be provided in each tutor's discipline. Students may enroll through the twelfth week of the semester. This course is open to all students. Grades are on a credit/no-credit basis.

8266	LAB	- 3:10 hrs	TBA	ALLEN, J F	LRC 103A
------	-----	------------	-----	------------	----------

LEARNING SKILLS 040 - INTRODUCTION TO LEARNING DISABILITIES (NDA) - 1.00 UNITS Rpt 3

3688	LEC	- 3:10 hrs	TBA	MATRANGA, S B	CH 109
8268	LEC	- 3:10 hrs	TBA	MATRANGA, S B	LRC 107
8269	LEC	- 3:10 hrs	TBA	SMITH, A L	LRC 107

LEARNING SKILLS 041 - STUDY STRATEGIES FOR STUDENTS WITH LEARNING DISABILITIES (NDA) - 3.00 UNITS Rpt 2

8270	LEC	- 2:05 hrs	TBA	SMITH, A L	LRC 107
AND	LAB	- 2:05 hrs	TBA	SMITH, A L	LRC 107

LEARNING SKILLS 043 - ADAPTIVE WORD PROCESSING OPERATIONS (NDA) - 1.00 UNITS Rpt 3

8276	LAB	- 3:10 hrs	TBA	SMITH, A L	BUNG 103
------	-----	------------	-----	------------	----------

LEARNING SKILLS 049 - INTRO TO COMPUTER ASSISTED INSTRUCTION APPLICATION (NDA) - 0.50 UNITS Rpt 3

Introduction to Computer Assisted Instruction Application is designed to introduce all students to the computer as a tool for learning by using hands-on computer interactive programs. Depending upon the diagnostic assessment, students will be placed in an appropriate program. Students may enroll through the twelfth week of the semester. This course is open to all students. Grades are on a credit/no-credit basis. (RPT3)

8277	LEC	- 1:05 hrs	TBA	ALLEN, J F	LRC 103A
------	-----	------------	-----	------------	----------

LEARNING SKILLS 050 - INTRO TO COMPUTER ASSISTED INSTRUCTION - LANGUAGE ARTS (NDA) - 0.50 UNITS Rpt

Introduction to Computer Assisted Instruction in the Language Arts is designed to introduce students to CAI Programs in the Language Arts by using hands-on interactive instructional applications programs. Depending upon the diagnostic assessment, students will be placed in an appropriate program. Students may enroll through the twelfth week of the semester. This course is open to all students. Grades are on a credit/no-credit basis. (RPT3)

8278	LAB	- 1:05 hrs	TBA	DES VIGNES, M	LRC 103A
------	-----	------------	-----	---------------	----------

LEARNING SKILLS 052 - TEST PREPARATION FOR THE GED: LITERATURE AND ARTS (NDA) - 1.00 UNITS Rpt 3

ADVISORIES: English 20, LS 1 A-C. This course is designed to prepare students to pass the General Educational Development (GED): Literature and the Arts Test. It will include critical thinking skills - reading comprehension skills, interpret graphs, analysis in literature and the arts, tone and style/prose fiction, interpret poetry, interpret drama, interpret plays, interpret non-fiction and commentaries. Depending upon the diagnostic assessment, students will be placed in an appropriate program. Students may enroll through the twelfth week of the semester. This course is open to all students. Grades are on a credit/no-credit basis. (RPT3)

8585	LEC	- 1:05 hrs	TBA	ALLEN, J F	LRC 103A
AND	LAB	- 4:15 hrs	TBA	ALLEN, J F	LRC 103A

LEARNING SKILLS 053 - TEST PREPARATION FOR THE GED: WRITING SKILLS (NDA) - 1.00 UNITS Rpt 3

ADVISORIES: English 20, LS 2A-C, LS 7A-C. This course is designed to prepare students to pass the General Educational Development Test (GED): Writing Skills Test. It will include basic grammar and usage skills, sentence structure, capitalization, spelling, and the essay. Depending upon the diagnostic assessment, students will be placed in an appropriate program. Students may enroll through the twelfth week of the semester. This course is open to all students. Grades are on a credit/no-credit basis. (RPT3)

8586	LEC	- 1:05 hrs	TBA	ALLEN, J F	LRC 103A
AND	LAB	- 4:15 hrs	TBA	ALLEN, J F	LRC 103A

LEARNING SKILLS 054 - TEST PREPARATION FOR GED: SCIENCE TEST (NDA) - 1.00 UNITS Rpt 3

ADVISORIES: English 20, LS 1 A-C. This course is designed to prepare students to pass the General Educational Development (GED): Science Test. It will include biology, earth science, astronomy, geology, meteorology, chemistry, and physics. Depending upon the diagnostic assessment, students will be placed in an appropriate program. Students may enroll through the twelfth week of the semester. This course is open to all students. Grades are on a credit/no-credit basis. (RPT3)

8587	LEC	- 1:05 hrs	TBA	ALLEN, J F	LRC 103A
AND	LAB	- 4:15 hrs	TBA	ALLEN, J F	LRC 103A

LEARNING SKILLS 055 - TEST PREPARATION FOR THE GED: MATHEMATICS (NDA) - 1.00 UNITS Rpt 3

ADVISORIES: Math 105, LS 10A-C. This course is designed to prepare students to pass the General Educational Development (GED): Mathematics Test. It will include arithmetic, the metric system, algebra, geometry, statistics, and probability problems. Depending upon the diagnostic assessment, students will be placed in an appropriate program. Students may enroll through the twelfth week of the semester. This course is open to all students. Grades are on a credit/no-credit basis. (LPT3)

8588	LEC	- 1:05 hrs	TBA	ALLEN, J F	LRC 103A
AND	LAB	- 4:15 hrs	TBA	ALLEN, J F	LRC 103A

SECTION# TIME DAYS INSTRUCTOR LOCATION

LEARNING SKILLS 056 - TEST PREPARATION FOR THE GED: SOCIAL SCIENCE (NDA) - 1.00 UNITS Rpt 3

DESCRIPTION: This course is designed to prepare students to pass the GED: Social Science Test. It will include the thirteen English colonies, the Revolutionary War, inflation and its effects, the various branches of government, time zones, anthropology, sociology, and psychology.

8589 LEC - 1:05 hrs TBA ALLEN, J F LRC 103A
AND LAB - 4:15 hrs TBA ALLEN, J F LRC 103A

LEARNING SKILLS 485 - INTERNET RESERCH (CSU) - 1.00 UNITS

The Internet Research course teaches students how to use search engines; basic and advanced searches with boolean operators; how to locate, store, and retrieve materials in various content fields; how to critically evaluate these sources; and how to use and cite electronic resources. Depending upon the diagnostic assessment, students will be placed in an appropriate program. Students may enroll through the twelfth week of the semester. Grades are on a credit/no-credit basis. (RPT2)

0155 LAB - 2:05 hrs TBA SMITH, A L CH 109
8279 LAB - 2:05 hrs TBA ALLEN, J F LRC 103A

LIBRARY SCIENCE

Chair: Barbara Vasquez, LIB216 (323) 953-4000 ext 2407
<http://library.lacitycollege.edu>

LIBRARY SCIENCE 101 - LIBRARY RESEARCH METHODS (CSU) - 1.00 UNITS

DESCRIPTION: Individualized instruction in the use of the library, its resources, and the rudiments of research. Credit/No Credit course.
8281 LAB - 1:00 hrs TBA GODDARD, R K LIB 119

LINGUISTICS

Chair: Tammy Robinson, SCI324N (323) 953-4000 ext 2700
<http://catalog.lacitycollege.edu/pages/english.html>

LINGUISTICS 001 - INTRODUCTION TO LANGUAGE AND LINGUISTICS (UC:CSU) - 3.00 UNITS

PREREQUISITE: English 28 Introduction to the scientific study of language to gain an understanding of language structures, functions, linguistic universals, and the relationship between language and cognition.

3385 LEC 5:15 pm - 6:40 pm T Th MARDIRUSSIAN, G FH 205

MANAGEMENT

Chair: Thelma Day, AD304 (323) 953-4000 ext. 2541
<http://www.lacitycollege.edu/academic/departments/busad/index.html>

MANAGEMENT 002 - ORGANIZATION AND MANAGEMENT THEORY (CSU) - 3.00 UNITS

PREREQUISITE: Business 1. DESCRIPTION: A study of the process of management, the establishment and achievement of objectives, decision making, organization, planning, control, and managerial authority.

0801 LEC 10:35 am - 12:00 pm T Th EGREGOR, A E AD 301A
3387 LEC 6:50 pm -10:00 pm W EGREGOR, A E DH 303

MANAGEMENT 013 - SMALL BUSINESS ENTREPRENEURSHIP (CSU) - 3.00 UNITS

DESCRIPTION: Designed to teach the student how to organize and operate a small business.

0800 LEC - 2:50 hrs TBA HASTEY, R B ON LINE
hasteyrb@lacitycollege.edu
3389 LEC 6:50 pm -10:00 pm M OWENS, T M AD 309

SECTION# TIME DAYS INSTRUCTOR LOCATION

MANAGEMENT 031 - HUMAN RELATIONS FOR EMPLOYEES (CSU) - 3.00 UNITS

ADVISORY: English 28 or equivalent. DESCRIPTION: Helps the student to recognize and develop those traits necessary for good relations with fellow workers, supervisors, subordinates, customers, and other business associates.

0806 LEC 10:35 am - 12:00 pm T Th BELL, B AD 303
1775 LEC 12:10 pm - 3:20 pm M GUYNES, L C AD 306

MANAGEMENT 033 - PERSONNEL MANAGEMENT (CSU) - 3.00 UNITS

ADVISORY: English 28 or equivalent. DESCRIPTION: This course covers the essentials of human resource management. Topics include recruitment, selection, training, appraisals, compensations, benefits, labor relations and collective bargaining.

3211 LEC 6:50 pm -10:00 pm M GUYNES, L C AD 306
3377 LEC 6:50 pm -10:00 pm T POWE, V AD 301B

MARKETING

Chair: Thelma Day, DH212 (323) 953-4000 ext. 2900
<http://www.lacitycollege.edu/academic/departments/busad/index.html>

MARKETING 001 - PRINCIPLES OF SELLING (CSU) - 3.00 UNITS

DESCRIPTION: The student will learn about selling careers, role of personality in selling, how to use product knowledge, prospecting, how to start the sale, demonstrate the product, handle sales resistance, and close the sale.

0811 LEC 10:35 am - 12:00 pm M W SCHENCK, L R AD 309
3393 LEC 6:50 pm -10:00 pm W SCHENCK, L R AD 309

MARKETING 011 - FUNDAMENTALS OF ADVERTISING (CSU) - 3.00 UNITS

ADVISORY: English 28 or equivalent. DESCRIPTION: Open to all students. Provides the student with an opportunity to explore the strategies and techniques used by small business, corporations and advertising agencies to stimulate sales.

1375 LEC 9:00 am - 10:25 am T Th EGREGOR, A E AD 306
3776 LEC 6:50 pm -10:00 pm M EGREGOR, A E DH 303

MARKETING 021 - PRINCIPLES OF MARKETING (CSU) - 3.00 UNITS

ADVISORY: English 28 or equivalent. DESCRIPTION: Open to all students. The student will explore types of markets and their characteristics, planning the products, selection of dealers and distributors, promotion of the products, international marketing.

0813 LEC 9:00 am - 10:25 am T Th SCHENCK, L R AD 309
3397 LEC 6:50 pm -10:00 pm T SCHENCK, L R AD 301A

MATHEMATICS

Chair: Roger Wolf, FH1010 (323) 953-4000 ext. 2810
<http://www.lacitycollege.edu/academic/departments/math/mathdept/index.html>

MATHEMATICS 100 - MATHEMATICS WORKSHOP (NDA) - 1.00 UNITS Rpt 3

DESCRIPTION: This course is designed to supplement and enhance learning experience by providing tutorial and self-help assistance, using tutorial assistance, calculators, computers, programmed texts, and other learning aids.

0836 LAB - 3:10 hrs TBA MARDIROSIAN, R FH 104

MATHEMATICS 105 - ARITHMETIC (NDA) - 3.00 UNITS

DESCRIPTION: Open to all students. Reviews the fundamentals of arithmetic that are essential to success in many college courses. Administrative management of this course will be totally on line. Your enrollment is not complete until you download and follow all course instructions, which are accessible on line at the Math 105 website: <http://www.lacitycollege.edu/academic/departments/mathdept/math105.html>. Student work in this course is entirely computer based and self paced. Students will

MATHEMATICS COURSE SEQUENCE

The LACC Assessment Center's process places student at the proper level in this sequence.

Track 1 MATH/Science

Track 2 Liberal Arts / Business

All 100-level Math courses do not transfer to UC or CSU but are prerequisites to higher level courses as shown in this flow chart.

All Math-105 classes are ONLINE

Requirement for AA degree is Math 115* or the Math 113, 114 sequence* or passing the LACC Math Competency Test
* STARTING FALL 2009 Math 125 is required for AA Degree

Math 125 or the Math 124A, 124B sequence is the prerequisite for all first level transfer courses: Math 215, 236, 227, 230 or 245

College Level Transfer Courses. Math/Science/Engineering Majors need Math 240
UC Transfers may need Math 261 and 262 Specialty Transfers: Teachers: Math 215 and 216
Business Majors: Math 236 and 237

Higher Level Math Courses

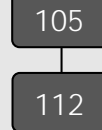
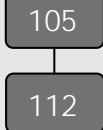

Math Tutoring Lab
Shop
100
202

Using the
Computer for Math
135

Math 105 – Arithmetic for College Students
Math 112 – Pre-Algebra
Math 113 – Elementary Algebra A
Math 114 – Elementary Algebra B
Math 115 – Elementary Algebra
Math 121 – Essentials of Geometry
Math 124A – Intermediate Algebra A
Math 124B – Intermediate Algebra B
Math 125 – Intermediate Algebra
Math 215 – Principles of Mathematics I
Math 216 – Principles of Mathematics II
Math 226 – Elementary Statistics Problem Solving
Math 227 – Statistics

Math 230 – Mathematics for Liberal Arts
Math 236 – Calculus for Business and Social science II
Math 237 – Advanced Calculus for Business and Social Science III
Math 240 – Trigonometry
Math 245 – College Algebra
Math 260 – Precalculus
Math 261 – Calculus I
Math 262 – Calculus II
Math 263 – Calculus III
Math 270 – Linear Algebra
Math 272 – Methods of Discrete Mathematics
Math 275 – Ordinary Differential Equations

SECTION#	TIME	DAYS	INSTRUCTOR	LOCATION
be required to attend three hours per week of scheduled computer laboratory work sessions on campus in a specified computer laboratory.				
*** Denotes homework and/or tests will be done on computers.				
0274	- 3:10 hrs	TBA	BADALIAN, R	ON LINE

MATHEMATICS 112 - PRE-ALGEBRA (NDA) - 3.00 UNITS

PREREQUISITE: Mathematics 105 or equivalent. DESCRIPTION: Bridges the gap between Arithmetic and Algebra. In addition to a brief review of Arithmetic, topics include signed numbers, laws of exponents, polynomial operations, mathematical sentences, and an introduction to graphs in Cartesian coordinates. NOTE: *** Denotes homework and/or tests will be done on computers.

0829	LEC	10:35 am - 12:00 pm	T Th	KENDIS, R G	FH 102
0834	LEC	9:00 am - 10:25 am	T Th	KHAWZA, Z	FH B16
0835*	LEC	9:00 am - 10:25 am	M W	WINDSOR, K R	FH B16
0839	LEC	1:45 pm - 3:10 pm	M W	PAHL, J	FH 102
0840*	LEC	1:45 pm - 3:10 pm	T Th	PAYNE, N	FH 102
0852	LEC	12:10 pm - 1:35 pm	T Th	ABAYACHI, M A	FH 102
0854	LEC	9:00 am - 12:10 pm	F	KIM, H	FH 102
0855	LEC	9:00 am - 12:10 pm	S	ACCAD, E	FH 102
0856	LEC	10:35 am - 12:00 pm	M W	KENDIS, R G	FH 102
0881*	LEC	12:10 pm - 1:35 pm	M W	BADALIAN, R	FH 102

Special tutorial assistance available to students in section 0881.

3407	LEC	6:50 pm - 10:00 pm	M	SUBRAMANIAN, V	FH 112
3408	LEC	6:50 pm - 10:00 pm	W	FERRELL, W D	FH 112
3409	LEC	6:50 pm - 10:00 pm	T	FERRELL, W D	FH 112
3410	LEC	6:50 pm - 10:00 pm	Th	HENTSCHEL, D H	FH 112

Special tutorial assistance available to students in section 3410.

3775*	LEC	3:40 pm - 5:05 pm	T Th	PAYNE, N	FH 102
-------	-----	-------------------	------	----------	--------

MATHEMATICS 113 - ELEMENTARY ALGEBRA A - 3.00 UNITS

PREREQUISITE: Mathematics 112 or equivalent. DESCRIPTION: Mathematics 113 and 114 together are equivalent to Mathematics 115 (see course description for Mathematics 115). Credit is allowed in only one Mathematics 115, or the Mathematics 113 and 114 combination. Simultaneous enrollment in Math 113 and 114 is not permitted.

NOTE: *** Denotes homework and/or tests will be done on computers.

0893	LEC	10:35 am - 12:00 pm	T Th	KAVIANI, K	FH 118
Special tutorial assistance available to students in section 0893.					
0921*	LEC	9:00 am - 12:10 pm	S	NIKOLAYCHUK, A	FH 116
0922*	LEC	12:10 pm - 1:35 pm	M W	PAYNE, N	FH 118

Special tutorial assistance available to students in section 0922.

3658	LEC	6:50 pm - 8:15 pm	M W	AKA, D O	FH 108
-------------	------------	--------------------------	------------	-----------------	---------------

MATHEMATICS 114 - ELEMENTARY ALGEBRA B - 3.00 UNITS

PREREQUISITE: Mathematics 113. This is the first half of Mathematics 115. Mathematics 113 and Mathematics 114 together are equivalent to Mathematics 115 (see course description for Mathematics 115). Credit is allowed in only one Mathematics 115, or Mathematics 113 and 114 combination. Simultaneous enrollment in Mathematics 113 and Mathematics 114 is not permitted.

0885	LEC	12:10 pm - 1:35 pm	T Th	VARDANYAN, V V	FH 118
3382	LEC	8:25 pm - 9:50 pm	M W	AKA, D O	FH 108

MATHEMATICS 115 - ELEMENTARY ALGEBRA - 5.00 UNITS

PREREQUISITE: Mathematics 112 or equivalent. NOTE: *** Denotes homework and/or tests will be done on computers. DESCRIPTION: This course is for those who have had no algebra or whose preparation in algebra is deficient. Topics include variables, polynomials, equations, factoring, systems of linear equations, graphs, inequalities and quadratic equations.

0862	LEC	7:40 am - 8:50 am	MTWTh	PLOTQUIN, H A	FH 110
0864*	LEC	9:00 am - 10:10 am	MTWTh	SOW, M N	FH 102
Special tutorial assistance available to students in section 0864.					
0865*	LEC	10:35 am - 12:00 pm	M W	SALAZAR, J M	FH 110
AND	LEC	10:35 am - 12:40 pm	F	SALAZAR, J M	FH 110
0866	LEC	9:00 am - 10:10 am	MTWTh	PAHL, J	FH 112
0867	LEC	10:35 am - 11:45 am	MTWTh	PLOTQUIN, H A	FH 108
0868*	LEC	10:35 am - 11:45 am	MTWTh	WINDSOR, K R	FH B16

SECTION#	TIME	DAYS	INSTRUCTOR	LOCATION	
0869	LEC	12:10 pm - 1:20 pm	MTWTh	BERNS, J A	FH 108
0870	LEC	12:10 pm - 1:20 pm	MTWTh	BLACKISTON, R A	FH B14
0875*	LEC	2:10 pm - 3:20 pm	MTWTh	SOW, M N	FH 112
3411*	LEC	4:00 pm - 6:30 pm	M W	HENTSCHEL, D H	FH 102
3412	LEC	4:00 pm - 6:30 pm	T Th	LEE, S	FH 108
3413	LEC	7:00 pm - 9:30 pm	M W	BAKER, C T	FH B16
3414	LEC	7:00 pm - 9:30 pm	T Th	MASON, S E	FH B16
3420*	LEC	7:00 pm - 9:30 pm	M W	MAGEE, I S	FH 102
3639	LEC	7:00 pm - 9:30 pm	T Th	HALAKA, E F	FH B14

MATHEMATICS 121 - ESSENTIALS OF PLANE GEOMETRY - 3.00 UNITS

Prerequisite: Mathematics 115 or equivalent. DESCRIPTION: This course covers the definitions, axioms and theorems of geometry relating to angles, lines, circles and polygons. Basic constructions are introduced. The meaning and techniques of logical proofs are heavily emphasized.

0871	LEC	10:35 am - 12:00 pm	M W	BLACKISTON, H S	FH 118
0872	LEC	12:10 pm - 1:35 pm	T Th	STAFF	FH 112
3648	LEC	6:50 pm - 10:00 pm	Th	ARRIOLA, P	FH 118

MATHEMATICS 124A - INTERMEDIATE ALGEBRA A - 2.50 UNITS

Prerequisite: Mathematics 115 or equivalent. The student learns the first part of Mathematics 125. Mathematics 124A and 124B together are equivalent to Mathematics 125. Topics include linear functions, systems of equations, inequalities, polynomials, rational functions, and exponents. Credit is allowed in only one Mathematics 125, or the Mathematics 124A and 124B combination. Simultaneous enrollment in Math 124A and 124B is not permitted. NOTE: *** Denotes homework and/or tests will be done on computers.

0830*	LEC	1:45 pm - 2:45 pm	M W	MARDIROSIAN, R	FH 108
AND	LAB	2:45 pm - 3:10 pm	M W	MARDIROSIAN, R	FH 108
3640	LEC	6:50 pm - 7:50 pm	T Th	SOW, M N	FH 108
AND	LAB	7:50 pm - 8:15 pm	T Th	SOW, M N	FH 108

MATHEMATICS 124B - INTERMEDIATE ALGEBRA B - 2.50 UNITS

Prerequisite: Mathematics 124A or equivalent. The student learns the second part of Mathematics 125. Mathematics 124A and 124B together are equivalent to Mathematics 125. Topics include quadratic functions and equations; composite, inverse exponential and logarithmic functions; conic sections; and sequences, series, and binomial theorem. Credit is allowed in only one Mathematics 125, or the Mathematics 124A and 124B combination. Simultaneous enrollment in Math 124A and 124B is not permitted.

0832	LEC	1:45 pm - 2:45 pm	T Th	PAHL, J	FH 108
AND	LEC	2:45 pm - 3:10 pm	T Th	PAHL, J	FH 108
3428	LEC	8:25 pm - 9:25 pm	T Th	SOW, M N	FH 108
AND	LAB	9:25 pm - 9:50 pm	T Th	SOW, M N	FH 108

MATHEMATICS 125 - INTERMEDIATE ALGEBRA - 5.00 UNITS

PREREQUISITE: Mathematics 115 or equivalent. Students the laws of exponents, equations in one variable (linear, quadratic, and some of higher degree), systems of linear and non-linear equations, graphical representations, exponential and logarithmic functions, complex numbers, and binomial theorem.

NOTE: *** Denotes homework and/or tests will be done on computers.

0845*	LEC	7:15 am - 8:50 am	M WTh	MAGEE, I S	FH 108
0876*	LEC	7:40 am - 8:50 am	MTWTh	WINDSOR, K R	FH B16
0877*	LEC	9:00 am - 10:10 am	MTWTh	SALAZAR, J M	FH B14
0878*	LEC	9:00 am - 10:10 am	MTWTh	PAYNE, N	FH 110
0879*	LEC	10:35 am - 11:45 am	MTWTh	MARDIROSIAN, R	FH B14
0880	LEC	10:35 am - 11:45 am	MTWTh	SOW, M N	FH 121
0882	LEC	12:10 pm - 1:20 pm	MTWTh	GHAHRAMANYAN,	FH 121
0883*	LEC	2:10 pm - 3:20 pm	MTWTh	SALAZAR, J M	FH B14
0927	LEC	- 5:20 hrs	TBA	ARAEIPOUR, M R	ON LINE
araeipmr@lacitycollege.edu					
3415	LEC	4:00 pm - 6:30 pm	M W	KAVIANI, K	FH 108
3417	LEC	7:00 pm - 9:30 pm	T Th	KING, W S	FH 110
3422	LEC	7:00 pm - 9:30 pm	T Th	LEE, V H	FH 102
3426	LEC	7:00 pm - 9:30 pm	M W	ESMAILI, S J	FH B14
3453	LEC	4:00 pm - 6:30 pm	T Th	HENTSCHEL, D H	FH 112

SECTION#	TIME	DAYS	INSTRUCTOR	LOCATION
MATHEMATICS 135 - USING THE COMPUTER FOR MATHEMATICS (CSU) - 1.00 UNITS				
Prerequisite: Mathematics 125 or equivalent. Advisory: Mathematics 245 or equivalent. Note: To complete enrollment, student must contact instructor.				
0324	LEC	- 0:30 hrs	TBA	KAVIANI, K FH 120
AND	LAB	- 1:00 hrs	TBA	KAVIANI, K FH 120

SECTION#	TIME	DAYS	INSTRUCTOR	LOCATION
MATHEMATICS 202 - MATHEMATICS WORKSHOP (CSU) - 1.00 UNITS Rpt 3				
This course is designed to supplement and enhance learning in mathematics by providing tutorial and self-help assistance, calculators, computers, programmed text, and other learning aids for baccalaureate level mathematics courses. Simultaneous enrollment in Mathematics 100 and Mathematics 202 is not permitted.				
NOTE: "*" Denotes homework and/or tests will be done on computers.				
0904*	LEC	- 3:10 hrs	TBA	MARDIROSIAN, R FH 104

SECTION#	TIME	DAYS	INSTRUCTOR	LOCATION
MATHEMATICS 215 - PRINCIPLES OF MATHEMATICS I (UC:CSU) - 3.00 UNITS				
PREREQUISITE: Mathematics 125 or equivalent. This course is the first of two in a sequence designed for prospective elementary school teachers. Topics include sets and relations, numbering systems, and elementary number theory. The main concern, however, will be understanding the structure of systems of whole numbers, integers, and rational numbers. NOTE: "*" Denotes homework and/or tests will be done on computers.				
0886	LEC	8:50 am - 12:00 pm	S	KARAPETYAN, A FH 108
AND	LEC	12:50 pm - 4:00 pm	S	KARAPETYAN, A FH 108
<i>(7 Week Class - Starts 8/30/2010, Ends 10/16/2010)</i>				
5091*	LEC	6:50 pm - 10:00 pm	T	HENTSCHEL, D H FH 118

SECTION#	TIME	DAYS	INSTRUCTOR	LOCATION
MATHEMATICS 216 - PRINCIPLES OF MATHEMATICS II (UC:CSU) - 3.00 UNITS				
PREREQUISITE: Mathematics 215 or equivalent. This course is the second of two in a sequence for prospective elementary school teachers. Topics include decimal and real numbers, rational numbers, abstract mathematical systems, geometry and the metric system.				
0887	LEC	8:50 am - 12:00 pm	S	KARAPETYAN, A FH 108
AND	LEC	12:50 pm - 4:00 pm	S	KARAPETYAN, A FH 108
<i>(7 Week Class - Starts 10/23/2010, Ends 12/19/2010)</i>				

SECTION#	TIME	DAYS	INSTRUCTOR	LOCATION
MATHEMATICS 227 - STATISTICS (UC:CSU) - 4.00 UNITS				
PREREQUISITE: Mathematics 125 or equivalent. NOTE: "*" Denotes homework and/or tests will be done on computers. DESCRIPTION: This course is an introduction to probability, descriptive and inferential statistics including measures of central tendency and dispersion, sampling, and estimation. Hypothesis testing, analysis of variance, test of independence, linear correlation and regression analysis also are covered.				
0841	LEC	9:00 am - 10:25 am	MTW	PLOTQUIN, H A FH 301
0874*	LEC	8:00 am - 12:30 pm	S	BADALIAN, R FH 117
0889	LEC	10:35 am - 12:40 pm	T Th	DANAKIAN, T FH 310
0890	LEC	12:10 pm - 2:15 pm	M W	KAVIANI, K FH B16
0891*	LEC	- 4:15 hrs	TBA	ARAEIPOUR, M R ON LINE
Section 0891 is an on line course. You must have internet access and a valid email address. To complete your enrollment, you must get course instructions by email from your professor at araeipmr@lacitycollege.edu and attend a mandatory on-campus orientation at the time and location provided by your professor through email.				
0902*	LEC	10:35 am - 12:00 pm	M W F	BADALIAN, R FH 310
1577	LEC	1:45 pm - 3:50 pm	T Th	KENDIS, R G FH 121
3418*	LEC	7:00 pm - 9:05 pm	M W	BADALIAN, R FH 121
3429	LEC	7:00 pm - 9:05 pm	T Th	DAKDOUK, R R FH 121
3449*	LEC	3:30 pm - 5:35 pm	M W	BADALIAN, R FH 121
5115*	LEC	3:30 pm - 5:35 pm	M W	BADALIAN, R FH 121
5116*	LEC	7:00 pm - 9:05 pm	M W	BADALIAN, R FH 121
5117	LEC	7:00 pm - 9:05 pm	T Th	STAFF FH 121
8065*	LEC	10:35 am - 12:00 pm	M W F	BADALIAN, R FH 310

SECTION#	TIME	DAYS	INSTRUCTOR	LOCATION
8068	LEC	1:45 pm - 3:50 pm	T Th	KENDIS, R G FH 121
8282	LEC	12:10 pm - 2:15 pm	M W	KAVIANI, K FH B16
8283	LEC	10:35 am - 12:40 pm	T Th	DANAKIAN, T FH 310
8284*	LEC	8:00 am - 12:30 pm	S	BADALIAN, R FH 117
8469	LEC	9:00 am - 10:25 am	MTW	PLOTQUIN, H A FH 301

SECTION#	TIME	DAYS	INSTRUCTOR	LOCATION
MATHEMATICS 227 H- STATISTICS (UC:CSU) - 4.00 UNITS				
8065	LEC	10:35 am - 12:00 pm	M W F	BADALIAN, R FH 310
8068	LEC	1:45 pm - 3:50 pm	T Th	KENDIS, R G FH 121
8282	LEC	12:10 pm - 2:15 pm	M W	KAVIANI, K FH B16
8283	LEC	10:35 am - 12:40 pm	T Th	DANAKIAN, T FH 310
8284	LEC	8:00 am - 12:30 pm	S	BADALIAN, R FH 117
8469	LEC	9:00 am - 10:25 am	MTW	PLOTQUIN, H A FH 301

SECTION#	TIME	DAYS	INSTRUCTOR	LOCATION
MATHEMATICS 230 - MATHEMATICS FOR LIBERAL ARTS STUDENTS (UC:CSU) - 3.00 UNITS				
PREREQUISITE: Mathematics 125 or equivalent. DESCRIPTION: This course is intended for liberal arts majors. Topics include sets and counting, probability, linear systems, linear programming, statistics and mathematics of finance with applications for liberal arts majors, and logic.				
NOTE: "*" Denotes homework and/or tests will be done on computers.				
0892*	LEC	10:35 am - 12:00 pm	T Th	PAYNE, N FH 116
3419	LEC	5:15 pm - 6:40 pm	T Th	ERICKSON, R W FH 118

SECTION#	TIME	DAYS	INSTRUCTOR	LOCATION
MATHEMATICS 236 - CALCULUS FOR BUSINESS AND SOCIAL SCIENCE (UC:CSU) - 5.00 UNITS				
PREREQUISITE: Math 125 or equivalent. DESCRIPTION: Calculus: limits, derivatives, optimization, antiderivatives, and definite integrals and their applications in Business, Economics, and Social Sciences. (This course contains some topics of Precalculus: Analysis of polynomial, rational, exponential and logarithmic functions, including their graphs.)				
NOTE: "*" Denotes homework and/or tests will be done on computers.				
0897*	LEC	9:00 am - 10:10 am	MTWTh	MARDIROSIAN, R FH 108

SECTION#	TIME	DAYS	INSTRUCTOR	LOCATION
MATHEMATICS 240 - TRIGONOMETRY (CSU) - 3.00 UNITS				
PREREQUISITE: Mathematics 125 or equivalent and Mathematics 121 or equivalent. DESCRIPTION: Analytical trigonometry and applications to right and oblique triangles are covered. Topics include inverse trigonometric functions and trigonometric equations.				
0899	LEC	9:00 am - 10:25 am	T Th	NIKOLAYCHUK, A FH 118
0900	LEC	1:00 pm - 4:10 pm	S	LEE, V H FH 118
3430	LEC	6:50 pm - 10:00 pm	W	STAFF FH 118

SECTION#	TIME	DAYS	INSTRUCTOR	LOCATION
MATHEMATICS 245 - COLLEGE ALGEBRA (UC:CSU) - 3.00 UNITS				
PREREQUISITE: Mathematics 125 or equivalent. DESCRIPTION: Topics include theory of equations, polynomial and rational functions and their graphs, systems of equations, matrices, determinants, permutations, combinations, probability, sequences and series, binomial theorem, mathematical induction.				
0898	LEC	9:00 am - 10:25 am	M W	NIKOLAYCHUK, A FH 118
0906	LEC	12:10 pm - 1:35 pm	T Th	KHAWZA, Z FH B16
3423	LEC	5:15 pm - 6:40 pm	T Th	PAYNE, N FH 110

SECTION#	TIME	DAYS	INSTRUCTOR	LOCATION
MATHEMATICS 260 - PRE-CALCULUS (UC:CSU) - 5.00 UNITS				
PREREQUISITE: Mathematics 240 or equivalent. DESCRIPTION: This course prepares students for calculus. Properties of polynomial, rational, algebraic, trigonometric, inverse trigonometric, exponential and logarithmic identities and equations are explored. Consult the course catalog for full details. NOTE: "*" Denotes homework and/or tests will be done on computers.				
0910*	LEC	9:00 am - 10:10 am	MTWTh	MAGEE, I S FH 116
3424*	LEC	7:00 pm - 9:30 pm	M W	MARDIROSIAN, R FH 110

SECTION#	TIME	DAYS	INSTRUCTOR	LOCATION
MATHEMATICS 261 - CALCULUS I (UC:CSU) - 5.00 UNITS				
PREREQUISITE: Mathematics 260 or equivalent. NOTE: "*" Denotes homework and/or tests will be done on computers. DESCRIPTION: Includes functions and their graphs, limits, continuity, derivatives of functions of one variable, Mean Value Theorem,				

SECTION#	TIME	DAYS	INSTRUCTOR	LOCATION
integrals, the Fundamental Theorem of Calculus, differentiation and integration of trigonometric functions and their applications.				
0909	LEC	10:35 am - 11:45 am	MTWTh	PAHL, J FH 112
0914	LEC	9:00 am - 10:10 am	MTWTh	KENDIS, R G FH 120
3425*	LEC	7:00 pm - 9:30 pm	T Th	NIKOLAYCHUK, A FH 116
3443	LEC	7:00 pm - 9:30 pm	M W	LEE, S FH 116

MATHEMATICS 261H - CALCULUS I - HONORS (UC:CSU) - 5.00 UNITS

5118	LEC	7:00 pm - 9:30 pm	M W	LEE, S FH 116
5119	LEC	7:00 pm - 9:30 pm	T Th	NIKOLAYCHUK, A FH 116
8069	LEC	9:00 am - 10:10 am	MTWTh	KENDIS, R G FH 120
8285	LEC	10:35 am - 11:45 am	MTWTh	PAHL, J FH 112

MATHEMATICS 262 - CALCULUS II (UC:CSU) - 5.00 UNITS

PREREQUISITE: Mathematics 261 or equivalent. DESCRIPTION: Includes the study of the differentiation and integration of transcendental functions, techniques of integration, sequences, infinite series, and curves in polar coordinates.

0911	LEC	9:00 am - 10:10 am	MTWTh	KAVIANI, K FH 121
3451	LEC	7:00 pm - 9:30 pm	M W	LEE, V H FH 120

MATHEMATICS 263 - CALCULUS III (UC:CSU) - 5.00 UNITS

PREREQUISITE: Mathematics 262 or equivalent. Includes vectors calculus, and parametric equations, surfaces, partial differentiation, gradient, maxima and minima for functions of several variables, multiple integrals, surface integrals, line integrals, Green's Theorem, Divergence Theorem, and Stokes' Theorem.

0917	LEC	10:35 am - 11:45 am	MTWTh	NIKOLAYCHUK, A FH 120
3427	LEC	7:00 pm - 9:30 pm	T Th	LEE, S FH 120
5121	LEC	7:00 pm - 9:30 pm	T Th	LEE, S FH 120
8287	LEC	10:35 am - 11:45 am	MTWTh	NIKOLAYCHUK, A FH 120

MATHEMATICS 270 - LINEAR ALGEBRA (UC:CSU) - 3.00 UNITS

PREREQUISITE: Mathematics 261 or equivalent. Students study vector spaces, linear transformation, matrices, matrix algebra, and solutions of systems of equations.

0919	LEC	9:00 am - 12:10 pm	S	LEE, V H FH 112
3456	LEC	3:40 pm - 5:05 pm	T Th	WOLF, R W FH 120

MATHEMATICS 275 - ORDINARY DIFFERENTIAL EQUATIONS (UC:CSU) - 3.00 UNITS

PREREQUISITE: Mathematics 262 or equivalent. DESCRIPTION: This course examines and applies techniques for solution of ordinary differential equations including first order equations, linear equations of higher order and linear systems of equations.

0920	LEC	1:00 pm - 4:10 pm	S	ZAKABI, L T FH 112
3459	LEC	5:15 pm - 6:40 pm	T Th	NIKOLAYCHUK, A FH 116

MICROBIOLOGY

Chair: Greg Gonsalves, SCI222E (323) 953-4000 ext. 2796
<http://www.lacitycollege.edu/academic/departments/lifesci/index.html>

MICROBIOLOGY 001 - INTRODUCTORY MICROBIOLOGY (UC:CSU) - 5.00 UNITS

PREREQUISITE: College chemistry and one course in biological science. DESCRIPTION: For pre-nursing, medical techs, public health majors, and allied health students.

3432	LEC	5:15 pm - 6:40 pm	T Th	HICKS, D R SCI 112
AND LAB	6:50 pm - 10:00 pm	T Th	HICKS, D R	SCI 112

MICROBIOLOGY 020 - GENERAL MICROBIOLOGY (UC:CSU) - 4.00 UNITS

ADVISORY: Eligibility in English 28 or its equivalent and Introductory Chemistry. DESCRIPTION: Students may be required to purchase or provide laboratory instructional materials. For pre-nursing and allied health students.

0930	LEC	8:50 am - 12:00 pm	T	HICKS, D R SCI 112
AND LAB	8:50 am - 12:00 pm	Th	HICKS, D R	SCI 112
0931	LEC	1:45 pm - 4:55 pm	M	HICKS, D R SCI 112
AND LAB	1:45 pm - 4:55 pm	W	HICKS, D R	SCI 112

SECTION#	TIME	DAYS	INSTRUCTOR	LOCATION
5094	LEC	6:50 pm - 10:00 pm	Th	YOUSSEF, M A SCI 130
AND LAB	6:50 pm - 10:00 pm	W	YOUSSEF, M A	SCI 112
8291	LEC	8:00 am - 11:10 am	S	SANCHEZ, D J SCI 111
AND LAB	12:00 pm - 3:10 pm	S	SANCHEZ, D J	SCI 112

MICROBIOLOGY 040 - MICROBIOLOGY LABORATORY PREPARATIONS (CSU) - 1.00 UNITS Rpt 2

ADVISORY: Completion of/or concurrent enrollment in Microbiology 1 or 20, or equivalent.

0932	LAB	- 3:10 hrs	TBA	HICKS, D R SCI 112
------	-----	------------	-----	-----------------------

MUSIC

Chair: Dan Wanner, CH243 (323) 953-4000 ext. 2880
<http://music.lacitycollege.edu>

MUSIC 101 - FUNDAMENTALS OF MUSIC (UC:CSU) - 3.00 UNITS

DESCRIPTION: (For the non-music major.) A study of the fundamentals of music including notation, major and minor key signatures and scales, intervals, time signatures and rhythms, and triads. Some sight reading and ear training is included. Satisfies Humanities requirement.

0935	LEC	9:00 am - 10:25 am	T Th	KELLY, K J CH 204
0936	LEC	9:00 am - 10:25 am	M W	GENGARO, C L CH 204

Special tutorial assistance available to students in section 0936.

3303	LEC	6:50 pm - 10:00 pm	W	KELLY, K J CH 204
-------------	------------	---------------------------	----------	------------------------------------

MUSIC 111 - MUSIC APPRECIATION I (UC:CSU) - 3.00 UNITS

DESCRIPTION: (Open to all students) Course offers a broad survey of musical masterpieces from the Middle Ages up to and including the 20th Century with emphasis on perceptive listening. Fulfills Humanities requirements for graduation.

0938	LEC	9:00 am - 12:10 pm	F	HENDERSON, L L CH 247
3436	LEC	6:50 pm - 10:00 pm	T	DUTTON, D L CH 247
8296	LEC	9:00 am - 10:25 am	M W	BLAKE, C M CH 247

MUSIC 120 - MUSIC TECHNOLOGY PRACTICE LAB - 0.50 UNITS Rpt 3

CO-REQUISITE: Either Music 161, 241, 242, 243, 244, 261, 281, 282, 291, 292, 293, or 294. DESCRIPTION: This course allows students currently enrolled in any of the co-requisite music technology classes to use the lab equipment and materials to enhance applicable skills necessary for success.

8575	LAB	- 3:10 hrs	TBA	WANNER, D A CH 206
------	-----	------------	-----	-----------------------

MUSIC 121 - MUSIC HISTORY AND LITERATURE I (UC:CSU) - 3.00 UNITS

ADVISORY: Music 111 and 202. DESCRIPTION: A survey of music history and literature from the earliest times to 1750.

1596	LEC	9:00 am - 10:25 am	M W	WANNER, D A CH 231
------	-----	--------------------	-----	-----------------------

MUSIC 135 - AFRICAN AMERICAN MUSIC - 3.00 UNITS

DESCRIPTION: A study of African American music and their influences on folk, spirituals, gospels, concert music, opera, ballet, blues, and jazz underscoring styles, characteristics, origin and contributions by African-American artists. (Credit allowed for only one of Music 135 and African-American Studies 60).

3053	LEC	6:50 pm - 10:00 pm	M	HENDERSON L CH 242
-------------	------------	---------------------------	----------	-------------------------------------

MUSIC 137 - MUSIC AS A BUSINESS - 3.00 UNITS

DESCRIPTION: A study of the music industry, the structure and requirements in terms of skills and knowledge of over 100 careers will be examined. Future industry changes and developments will also be discussed.

3680	LEC	6:50 pm - 10:00 pm	T	BURGER, M CH 206
-------------	------------	---------------------------	----------	-----------------------------------

MUSIC 140 - ADVANCED PRACTICE LAB - MUSIC TECHNOLOGY - 0.50 UNITS Rpt 3

PREREQUISITE: Music 120. DESCRIPTION: This course allows more advanced students, who are enrolled in any of the co-requisite courses of Music 120: Music

SECTION#	TIME	DAYS	INSTRUCTOR	LOCATION
----------	------	------	------------	----------

Technology Practice Lab, to use the lab equipment and materials to further enhance applicable skills necessary for success.

8301	LAB	- 3:10 hrs	TBA	WANNER, D A	CH 206
------	-----	------------	-----	-------------	--------

MUSIC 152 - CURRENT MUSICAL EVENTS (CSU) - 1.00 UNITS Rpt 3

Live musical performances of a wide variety of styles, including guest artists, chamber groups, students, faculty, departmental organizations, and lectures and demonstrations.

0939	LEC	12:10 pm - 1:10 pm	T Th	SUOVANEN, C R	CH 247
------	-----	--------------------	------	---------------	--------

MUSIC 161 - INTRODUCTION TO ELECTRONIC MUSIC (CSU) - 3.00 UNITS

DESCRIPTION: This course is a workshop in electro-acoustic, MIDI, and computer-assisted music techniques for both the Macintosh and PC platforms. Emphasis is in computer-assisted sequencing, digital and MIDI recording, mixing, sound reinforcement and CD production.

3682	LEC	5:15 pm - 7:20 pm	T	MCGAUGHEY, M G	CH 117
AND	LAB	7:20 pm - 9:25 pm	T	MCGAUGHEY, M G	CH 117
8298	LEC	1:45 pm - 3:50 pm	M	BLAKE, C M	CH 117
AND	LAB	3:50 pm - 5:55 pm	M	BLAKE, C M	CH 117
8299	LEC	1:45 pm - 3:50 pm	W	BLAKE, C M	CH 117
AND	LAB	3:50 pm - 5:55 pm	W	BLAKE, C M	CH 117
8300	LEC	- 2:05 hrs	TBA	BLAKE, C M	CH 117
AND	LAB	- 2:05 hrs	TBA	BLAKE, C M	CH 117

MUSIC 180 - APPLIED MUSIC LABORATORY (CSU) - 1.50 UNITS Rpt 3

CO-REQUISITE: Either Music 181, 182, 183 or 184. DESCRIPTION: This course allows students enrolled in Applied Music to practice a minimum of five hours per week in departmental practice facilities.

8304	LAB	- 5:10 hrs	TBA	WANNER, D A	CH 206
------	-----	------------	-----	-------------	--------

MUSIC 181 - APPLIED MUSIC I (UC:CSU) - 0.50 UNITS

CO-REQUISITE: Music 180. DESCRIPTION: Individual instruction in voice or a musical instrument for transfer-oriented music majors as determined by the Music Department. (Confirmation of enrollment subject to audition.)

8303	LEC	1:30 pm - 2:30 pm	F	PARK, C J	CH 206
------	-----	-------------------	---	-----------	--------

MUSIC 182 - APPLIED MUSIC II (UC:CSU) - 0.50 UNITS

PREREQUISITE: Music 181. CO-REQUISITE: Music 180. DESCRIPTION: Individual instruction in voice or a musical instrument for transfer-oriented music majors as determined by the Music Department. (Confirmation of enrollment subject to audition.)

8321	LEC	1:30 pm - 2:30 pm	F	PARK, C J	CH 206
------	-----	-------------------	---	-----------	--------

MUSIC 183 - APPLIED MUSIC III (UC:CSU) - 0.50 UNITS

PREREQUISITE: Music 182. CO-REQUISITE: Music 180. DESCRIPTION: Individual instruction in voice or a musical instrument for transfer-oriented music majors as determined by the Music Department. (Confirmation of enrollment subject to audition.)

8320	LEC	1:30 pm - 2:30 pm	F	PARK, C J	CH 206
------	-----	-------------------	---	-----------	--------

MUSIC 184 - APPLIED MUSIC IV (UC:CSU) - 0.50 UNITS

PREREQUISITE: Music 183. CO-REQUISITE: Music 180. The student receives fourth level individual instruction and master classes in voice or a musical instrument. For transfer-oriented music majors as determined by the Music Department. (Confirmation of enrollment subject to audition.)

8322	LEC	1:30 pm - 2:30 pm	F	PARK, C J	CH 206
------	-----	-------------------	---	-----------	--------

MUSIC 185 - DIRECTED STUDY - MUSIC (CSU) - 1.00 UNITS Rpt 2

Vocal and instrumental students pursue directed study on a contract basis under the direction of a supervising instructor. A maximum of 3 units in Directed Study may be taken for credit.

0339		- 1:05 hrs	TBA	WANNER, D A	CH 206
8305		- 1:05 hrs	TBA	WANNER, D A	CH 206
8306		- 1:05 hrs	TBA	BLAKE, C M	CH 117

SECTION#	TIME	DAYS	INSTRUCTOR	LOCATION
----------	------	------	------------	----------

MUSIC 200 - INTRODUCTION TO MUSIC THEORY (UC:CSU) - 4.00 UNITS

Corequisite: Music 300. The student learns the basic elements of music, notation, music reading, sight singing and ear training. Functions as the introductory course for the Music Major. Students taking this class should also enroll in Music 300.

0940	LEC	8:50 am - 10:55 am	T	GENGARO, C L	CH 206
AND	LAB	8:50 am - 12:00 pm	Th	GENGARO, C L	CH 206
0941	LEC	10:35 am - 12:00 pm	MTW	BLOMQUIST, J K	CH 204
AND	LAB	10:35 am - 11:00 am	Th	BLOMQUIST, J K	CH 205

MUSIC 201 - HARMONY I (UC:CSU) - 3.00 UNITS

PREREQUISITE: Music 200 with a satisfactory grade or better. Corequisite: Music 211 and 301. The student studies diatonic harmony including primary and secondary triads, the dominant seventh chord and their inversions. Also includes harmonizing figured and unfigured bass, simple melodies and the writing of original phrases. Students taking this class should also enroll in Music 211 and Music 301.

0943	LEC	10:35 am - 12:00 pm	M W	KELLY, K J	CH 242
------	-----	---------------------	-----	------------	--------

MUSIC 202 - HARMONY II (UC:CSU) - 3.00 UNITS

PREREQUISITE: Music 201 with a satisfactory grade or better. The student studies more advanced diatonic and chromatic harmony including seventh chords, modally borrowed chords, sequences, secondary dominants and secondary diminished sevenths, simple modulations and the writing of short original compositions. Students enrolling in this class should also enroll in Music 212 and Music 302.

0944	LEC	10:35 am - 12:00 pm	T Th	WANNER, D A	CH 239
------	-----	---------------------	------	-------------	--------

MUSIC 203 - HARMONY III (UC:CSU) - 3.00 UNITS

PREREQUISITE: Music 202 with a satisfactory grade or better. DESCRIPTION: Study of advanced chromatic harmony and analysis. Students demonstrate skill required by harmonizing figured and unfigured bass melodies and writing short original compositions. Students enrolling in Harmony III should also enroll in Music 213 and Music 303.

0170	LEC	10:35 am - 12:00 pm	M W	WANNER, D A	CH 231
------	-----	---------------------	-----	-------------	--------

MUSIC 211 - MUSICIANSHIP I (UC:CSU) - 2.00 UNITS

PREREQUISITE: Music 200 with a satisfactory grade or better. CO-REQUISITE: Music 201 and 301. The student reads and plays simple diatonic melodies, two part play-and-sing drills, and simple melodic, harmonic, and rhythmic dictation.

0945	LEC	10:35 am - 11:05 am	T Th	KELLY, K J	CH 242
AND	LAB	11:05 am - 12:00 pm	T Th	KELLY, K J	CH 242

MUSIC 212 - MUSICIANSHIP II (UC:CSU) - 2.00 UNITS

PREREQUISITE: Music 211 with a satisfactory grade or better. CO-REQUISITE: Music 202 and 302. The student reads and plays intermediate level tonal and modal melodies, melodic, harmonic, and rhythmic dictation. Sight singing and ear training are stressed.

0946	LEC	10:35 am - 11:05 am	M W	PARK, C J	CH 239
AND	LAB	11:05 am - 12:00 pm	M W	PARK, C J	CH 239

MUSIC 213 - MUSICIANSHIP III (UC:CSU) - 2.00 UNITS

PREREQUISITE: Music 212 with a satisfactory grades or better. Corequisite: Music 203 and 303. The student reads and plays advanced chromatic melodies, harmonies, and rhythms using sight singing, ear training, and dictation.

0174	LEC	10:35 am - 11:05 am	T Th	PARK, C J	CH 231
AND	LAB	11:05 am - 12:00 pm	T Th	PARK, C J	CH 231

MUSIC 220 - MUSIC THEORY AND LISTENING LAB - 0.50 UNITS Rpt 3

CO-REQUISITE: Either Music 200, 201, 202, 203, 211, 212, 213, 221, 222, 300, 301, 302 or 303. DESCRIPTION: This course allows students currently enrolled in any of the co-requisite music theory or listening classes to use the lab equipment and materials to enhance applicable skills necessary for success.

8572	LAB	- 3:10 hrs	TBA	WANNER, D A	CH 206
------	-----	------------	-----	-------------	--------

SECTION# TIME DAYS INSTRUCTOR LOCATION

MUSIC 221 - COUNTERPOINT I (UC:CSU) - 3.00 UNITS

PREREQUISITE: Music 202 with a satisfactory grade or equivalent. The student studies 18th-century contrapuntal techniques in two, three and four voices, including species counterpoint, invertible counterpoint, motive development and canon and resulting in analysis and composition of two-part inventions, binary dance forms and three and four-part fugue expositions.

3381 LEC 3:30 pm - 5:00 pm T Th KELLY, K J CH 239

MUSIC 222 - COUNTERPOINT II (UC:CSU) - 3.00 UNITS

PREREQUISITE: Music 221 with a satisfactory grade or equivalent. The student continues the study of 18th-century contrapuntal techniques including analysis and composition of three and four-voice fugues, chorale preludes, and contrapuntal variations.

8302 LEC 3:30 pm - 5:00 pm T Th KELLY, K J CH 239

MUSIC 240 - ADVANCED PRACTICE LAB- MUSIC THEORY AND LISTENING - 0.50 UNITS Rpt 3

PREREQUISITE: Music 220. Corequisite: Music 200 or 201 or 202 or 203 or 211 or 212 or 213, 221, 222 or 300 or 301 or 302 or 303. The student uses departmental labs to further enhance applicable skills necessary for success in the co-requisite course. For advanced students who have completed Music 220 four times.

8323 LAB - 3:10 hrs TBA WANNER, D A CH 206

MUSIC 241 - MUSIC NOTATION AND COPYING I (CSU) - 1.00 UNITS

DESCRIPTION: This course provides instruction and practical experience in the techniques and materials required for preparation of handwritten and computer generated scores. This course does not deal with music composition, but only with how to copy existing music in a professional manner.

8307 LEC 1:45 pm - 2:45 pm M KELLY, K J CH 231

MUSIC 242 - MUSIC NOTATION AND COPYING II (CSU) - 1.00 UNITS

PREREQUISITE: Music 241. DESCRIPTION: This course provides continued instruction in the development of basic techniques of music notation, drawing of notes, rests, symbols and characters used in music manuscript. Includes computer generated scores.

8308 LEC 1:45 pm - 2:45 pm M KELLY, K J CH 231

MUSIC 243 - MUSIC NOTATION AND COPYING III (CSU) - 1.00 UNITS

PREREQUISITE: Music 242. DESCRIPTION: This course provides advanced instruction and practical experience in the techniques of music notation as they apply to music manuscript including rhythm section notation and the construction of multiple layer chord parts. Includes computer generated scores.

8309 LEC 1:45 pm - 2:45 pm M KELLY, K J CH 231

MUSIC 244 - MUSIC NOTATION AND COPYING IV (CSU) - 1.00 UNITS

PREREQUISITE: Music 243. DESCRIPTION: This course provides advanced instruction and practical experience in the techniques of music notation as they apply to music manuscript including transposition for all instruments. Includes computer generated scores.

8310 LEC 1:45 pm - 2:45 pm M KELLY, K J CH 231

MUSIC 250 - MUSIC PERFORMANCE WORKSHOP (CSU) - 1.00 UNITS Rpt 3

DESCRIPTION: This course includes the preparation, rehearsal, and performance of selected musical works. Illustration and discussion of various concepts of musical performance are emphasized. (Confirmation of enrollment is subject to audition. See "auditions" box.) May be taken 4 times.

4570 LAB 12:15 pm - 3:25 pm S WRIGHT, E L CH 260

4571 LAB 4:30 pm - 7:40 pm S WRIGHT, E L CH 260

8311 LAB - 3:10 hrs TBA BLAKE, C M CH 117

SECTION# TIME DAYS INSTRUCTOR LOCATION

MUSIC 261 - ELECTRONIC MUSIC WORKSHOP (CSU) - 3.00 UNITS Rpt 2

PREREQUISITE: Music 161 and 101, with a satisfactory grade or better. The student learns advanced electro-acoustic, MIDI event and audio editing, digital audio data management and synchronization.

8313 LEC 10:00 am - 12:05 pm F BLAKE, C M CH 117

AND LAB 12:05 pm - 2:15 pm F BLAKE, C M CH 117

8314 LEC - 2:05 hrs TBA BLAKE, C M CH 117

AND LAB - 2:05 hrs TBA BLAKE, C M CH 117

MUSIC 281 - COMMERCIAL MUSIC TECHNIQUES I (CSU) - 3.00 UNITS

PREREQUISITE: Music 201 and 161 with satisfactory grades or better. DESCRIPTION: This is the first in a sequence of courses offering opportunity to develop techniques of music for commercial applications. Skills in the preparation of music for compact disk production, multi-media applications, audio production techniques. Songwriting and stage performance will be emphasized.

8315 LEC 10:00 am - 12:05 pm F BLAKE, C M CH 117

AND LAB 12:05 pm - 2:15 pm F BLAKE, C M CH 117

8316 LEC - 2:05 hrs TBA BLAKE, C M CH 117

AND LAB - 2:05 hrs TBA BLAKE, C M CH 117

MUSIC 282 - COMMERCIAL MUSIC TECHNIQUES II (CSU) - 3.00 UNITS

PREREQUISITE: Music 281. The student continues developing techniques of music for commercial applications. Advanced skills in the preparation of music for compact disc and DVD production, multimedia applications, audio production techniques, songwriting, score realization, stage performance and talent promotion will be emphasized.

8312 LEC 10:00 am - 12:05 pm F BLAKE, C M CH 117

AND LAB 12:05 pm - 2:15 pm F BLAKE, C M CH 117

8325 LEC - 2:05 hrs TBA BLAKE, C M CH 117

AND LAB - 2:05 hrs TBA BLAKE, C M CH 117

MUSIC 291 - MIDI INSTRUMENTS INSTRUCTION I (CSU) - 2.00 UNITS

PREREQUISITE: Music 161. ADVISORY: Music 261. The student develops functional skills to utilize synthesizers, digital keyboards, sequencers, digital audio interface, MIDI controllers, computers and other MIDI equipment.

8317 LEC 10:00 am - 11:05 am F BLAKE, C M CH 117

AND LAB 11:05 am - 1:10 pm F BLAKE, C M CH 117

8318 LEC - 1:05 hrs TBA BLAKE, C M CH 117

AND LAB - 2:05 hrs TBA BLAKE, C M CH 117

MUSIC 292 - MIDI INSTRUMENTS INSTRUCTION II (CSU) - 2.00 UNITS

PREREQUISITE: Music 291. The student continues to develop functional skills to utilize MIDI instruments. Emphasis is on advanced MIDI instrument techniques and applications in creative music technology using both Mac and PC computers.

8409 LEC 10:00 am - 11:05 am F BLAKE, C M CH 117

AND LAB 11:05 am - 1:10 pm F BLAKE, C M CH 117

8410 LEC - 1:05 hrs TBA BLAKE, C M CH 117

AND LAB - 2:05 hrs TBA BLAKE, C M CH 117

MUSIC 293 - MIDI INSTRUMENTS INSTRUCTION III (CSU) - 2.00 UNITS

PREREQUISITE: Music 292. The student continues to develop functional skills to utilize MIDI instruments. Emphasis is on advanced techniques in MIDI data, channel-voice messages, MIDI automation and non-registered parameters.

8411 LEC 10:00 am - 11:05 am F BLAKE, C M CH 117

AND LAB 11:05 am - 1:10 pm F BLAKE, C M CH 117

8412 LEC - 1:05 hrs TBA BLAKE, C M CH 117

AND LAB - 2:05 hrs TBA BLAKE, C M CH 117

SECTION# TIME DAYS INSTRUCTOR LOCATION

MUSIC 294 - MIDI INSTRUMENTS INSTRUCTION IV (CSU) - 2.00 UNITS

PREREQUISITE: Music 293. The student continues to develop functional skills to utilize MIDI instruments. Emphasis is on advanced techniques in MIDI synchronization with digital audio files and their use.

8577	LEC	10:00 am - 11:05 am	F	BLAKE, C M	CH 117
AND	LAB	11:05 am - 1:10 pm	F	BLAKE, C M	CH 117
8578	LEC	- 1:05 hrs	TBA	BLAKE, C M	CH 117
AND	LAB	- 2:05 hrs	TBA	BLAKE, C M	CH 117

MUSIC 300 - INTRODUCTION TO KEYBOARD HARMONY (UC:CSU) - 1.00 UNITS

CO-REQUISITE: Music 200. The student learns music theory as applied to the piano. Correlated with Music 200. Students are required to furnish their own headphones.

0947	LEC	11:00 am - 12:00 pm	Th	BLOMQUIST, J K	CH 205
0948	LEC	11:00 am - 12:00 pm	T	MUNT, J D	CH 205

MUSIC 301 - KEYBOARD HARMONY I (UC:CSU) - 1.00 UNITS

PREREQUISITE: Music 300. CO-REQUISITE: Music 201. The student studies diatonic harmony as applied to the piano. Correlated with Music 201 and 211.

8324	LEC	- 1:00 hrs	TBA	WANNER, D A	CH 205
8328	LEC	9:25 am - 10:25 am	T	WANNER, D A	CH 205

MUSIC 302 - KEYBOARD HARMONY II (UC:CSU) - 1.00 UNITS

PREREQUISITE: Music 301. CO-REQUISITE: Music 202. The student studies diatonic and simple chromatic harmony applied to the piano. Correlated with Music 202 and 212.

8295	LEC	- 1:00 hrs	TBA	PARK, C J	CH 230
8329	LEC	9:25 am - 10:25 am	T	PARK, C J	CH 230

MUSIC 303 - KEYBOARD HARMONY III (UC:CSU) - 1.00 UNITS

PREREQUISITE: Music 302. CO-REQUISITE: Music 203. The student studies advanced chromatic harmony applied to the piano. Correlated with Music 203 and 213.

0188	LEC	9:25 am - 10:25 am	Th	WANNER, D A	CH 230
0192	LEC	- 1:00 hrs	TBA	WANNER, D A	CH 230

MUSIC 311 - PIANO I (UC:CSU) - 1.00 UNITS

DESCRIPTION: Open to all students. This course consists of instruction in basic piano skills with emphasis on learning to read music, play finger-patterns, scales, chords, and beginning pieces. Students are required to furnish their own headphones.

0951	LAB	9:00 am - 11:05 am	F	THOMAS, L M	CH 205
0957	LAB	1:45 pm - 2:45 pm	M W	HANNIFAN, P	CH 205
0967	LAB	9:25 am - 10:25 am	M W	STAHL, D Q	CH 205
3438	LAB	6:50 pm - 8:55 pm	T	PETITTO, J	CH 205

MUSIC 312 - PIANO II (UC:CSU) - 1.00 UNITS

PREREQUISITE: Music 311 with a satisfactory grade or better. DESCRIPTION: Continuing instruction in basic piano skills emphasizing note reading, simple major and minor scales in quarter and eighth note patterns, triads, repertoire and memorization. Students are required to furnish their own headphones. (If prerequisite is not met, enrollment is subject to audition. See "auditions" box.)

1599	LAB	11:15 am - 1:25 pm	F	STAHL, D Q	CH 205
3448	LAB	6:50 pm - 8:55 pm	T	WILLIAMS, L P	CH 230

MUSIC 313 - PIANO III (UC:CSU) - 1.00 UNITS

PREREQUISITE: Music 312 with a satisfactory grade or better. DESCRIPTION: Continued instruction in developing piano skills with increasing emphasis on note reading, major and minor scale techniques, cadences, triads, repertoire from major historical periods, and memorization. Students are required to furnish their own headphones. (If prerequisite is not met, enrollment is subject to audition. See "auditions" box.)

5361	LAB	3:30 pm - 4:30 pm	M W	SWEENEY, C P	FH 114
8326	LAB	9:25 am - 10:25 am	M W	PARK, C J	CH 230

SECTION# TIME DAYS INSTRUCTOR LOCATION

MUSIC 314 - PIANO IV (UC:CSU) - 1.00 UNITS Rpt 3

PREREQUISITE: Music 313 with a satisfactory grade or better. DESCRIPTION: Instruction in piano skills emphasizing major and minor scales, major and minor arpeggios, repertoire from the Baroque, Classical, Romantic, and 20th Century, and memorization. Students are required to furnish their own headphones. (If prerequisite is not met, enrollment is subject to audition. See "auditions" box.)

5362	LAB	3:30 pm - 4:30 pm	M W	SWEENEY, C P	CH 230
8327	LAB	9:25 am - 10:25 am	M W	PARK, C J	CH 230

MUSIC 320 - ORGAN PRACTICE LAB - 0.50 UNITS Rpt 3

CO-REQUISITE: Music 185. DESCRIPTION: This course allows students currently enrolled in any of the co-requisite organ classes to use the lab equipment and materials to enhance applicable skills necessary for success.

8330	LAB	- 3:10 hrs	TBA	WANNER, D A	CH 206
------	-----	------------	-----	-------------	--------

MUSIC 340 - ADVANCED PRACTICE LAB - ORGAN - 0.50 UNITS Rpt 3

PREREQUISITE: Music 320 with a satisfactory grade or better or equivalent. Corequisite: Music 185. The student uses departmental organ practice rooms to further enhance applicable skills necessary for success in the co-requisite course. For advanced students who have completed Music 320 four times.

8331	LAB	- 3:10 hrs	TBA	WANNER, D A	CH 206
------	-----	------------	-----	-------------	--------

MUSIC 341 - INTERMEDIATE PIANO (UC:CSU) - 2.00 UNITS Rpt 3

PREREQUISITE: Music 314 with a satisfactory grade or better. DESCRIPTION: The study and performance of concert piano literature from the Baroque, Classical, and Romantic periods and the 20th Century. May be taken 4 times. (If prerequisite is not met, enrollment is subject to audition. See "auditions" box.)

0960	LEC	1:45 pm - 2:15 pm	T Th	PARK, C J	CH 230
AND	LAB	2:15 pm - 3:20 pm	T Th	PARK, C J	CH 230

MUSIC 351 - PIANO ENSEMBLE (UC:CSU) - 1.00 UNITS Rpt 3

The student reads, studies and performs standard piano ensemble repertoire with special emphasis on performance in recital. (Confirmation of enrollment subject to audition.)

8363	LAB	1:45 pm - 3:15 pm	M W	PARK, C J	CH 206
------	-----	-------------------	-----	-----------	--------

MUSIC 400 - VOICE FUNDAMENTALS (UC:CSU) - 1.00 UNITS

This course concentrates on basic fundamentals of singing, using vocal exercises and simple songs. Emphasis is placed on developing an understanding of the singing voice, the body as a musical instrument, and the vocal potential of each student.

0959	LAB	9:00 am - 11:05 am	F	MURRAY, S M	CH 242
0962	LAB	1:45 pm - 2:45 pm	T Th	BLOMQUIST, J K	CH 206
3440	LAB	6:50 pm - 8:55 pm	M	FULLER, L A	CH 206

MUSIC 401 - CLASSICAL VOICE I (UC:CSU) - 1.00 UNITS

PREREQUISITE: Music 400 with a satisfactory grade or better. The student concentrates on general basic fundamentals of singing using vocal exercises and simple arias and art songs in Italian. Italian pronunciation and vocal style will be studied. (If prerequisite is not met, enrollment is subject to audition.)

0970	LAB	11:15 am - 1:20 pm	F	ABBOTT, W C	CH 242
------	-----	--------------------	---	-------------	--------

MUSIC 402 - CLASSICAL VOICE II (UC:CSU) - 1.00 UNITS

PREREQUISITE: Music 401 with a satisfactory grade or better. DESCRIPTION: The student learns the basic fundamentals of singing using vocal exercises, simple arias and art songs in German. German pronunciation and vocal style are studied. (If prerequisite is not met, enrollment is subject to audition.)

8334	LAB	11:15 am - 1:20 pm	F	ABBOTT, W C	CH 242
------	-----	--------------------	---	-------------	--------

MUSIC 403 - CLASSICAL VOICE III (UC:CSU) - 1.00 UNITS

PREREQUISITE: Music 402 with a satisfactory grade or better. DESCRIPTION: The student learns the basic fundamentals of singing using vocal exercises, simple arias and art songs in French. French pronunciation and vocal style are studied. (If prerequisite is not met, enrollment is subject to audition.)

8335	LAB	11:15 am - 1:20 pm	F	ABBOTT, W C	CH 242
------	-----	--------------------	---	-------------	--------

SECTION# TIME DAYS INSTRUCTOR LOCATION

MUSIC 431 - COMMERCIAL VOICE I (CSU) - 1.00 UNITS

PREREQUISITE: Music 400 with a satisfactory grade or better. DESCRIPTION: A continued concentration of general basic fundamentals of singing using vocal exercises and songs selected from the commercial song literature. (If prerequisite is not met, enrollment is subject to audition. Bring the sheet music of a prepared song in your key to the first class meeting. See "auditions" box.)

0963 LAB 1:45 pm - 2:45 pm M W GENGARO, C L CH 204
3441 LAB 6:50 pm - 8:55 pm M GENGARO, C L CH 204

MUSIC 432 - COMMERCIAL VOICE II (CSU) - 1.00 UNITS

PREREQUISITE: Music 431 with a satisfactory grade or better. DESCRIPTION: The student concentrates on the singing voice using more difficult vocal exercises and songs from the many areas of commercial vocal music. Stylistic interpretation and performance practices are emphasized. Coaching sessions with class accompanist are included. (If prerequisite is not met, enrollment is subject to audition.)

5105 LAB 7:20 pm - 9:25 pm W GENGARO, C L CH 247
5336 LAB 3:30 pm - 5:35 pm M GENGARO, C L CH 247

MUSIC 433 - COMMERCIAL VOICE III (CSU) - 1.00 UNITS

PREREQUISITE: Music 432 with a satisfactory grade better. DESCRIPTION: The more advanced singer concentrates on stylistic interpretations and performance practices in a variety of commercial vocal music areas. This course includes coaching sessions with the class accompanist. Students who do not meet the prerequisite must audition to enroll in the class.

5106 LAB 7:20 pm - 9:25 pm W GENGARO, C L CH 247
8337 LAB 3:30 pm - 5:35 pm M GENGARO, C L CH 247

MUSIC 501 - COLLEGE CHOIR (UC:CSU) - 1.00 UNITS Rpt 3

The student studies and performs selected choral literature for mixed voices. Emphasis is on increased skill in music reading, development of basic voice and ensemble techniques, and improving musicianship.

0964 LAB 12:10 pm - 1:35 pm M W RUSSELL, J K CH 242

MUSIC 561 - CHAMBER CHORALE (UC:CSU) - 1.00 UNITS Rpt 3

The student analyzes, rehearses and performs choral music suited to a small group of singers, with and without accompaniment. Emphasis is on increased skill in reading music and sight singing, score interpretation, vocal technique, diction, and preparation for public performances. (Confirmation of enrollment subject to audition).

3442 LAB 5:15 pm - 6:40 pm T Th RUSSELL, J K CH 242

MUSIC 601 - BRASS INSTRUMENT INSTRUCTION I (UC:CSU) - 2.00 UNITS

The student receives basic instruction on the brass instruments, including trumpet, French horn, trombone and tuba. Some instruments available to loan to enrolled students. Open to all students.

8338 LEC 9:00 am - 9:30 am T Th LARONGA, B CH 242
AND LAB 9:30 am - 10:25 am T Th LARONGA, B CH 242

MUSIC 602 - BRASS INSTRUMENT INSTRUCTION II (UC:CSU) - 2.00 UNITS

PREREQUISITE: Music 601 with a satisfactory grade or better. The student learns more advanced brass instrument techniques with emphasis on the development of embouchure, range, endurance and music reading skills. Some instruments available to loan to enrolled students. (If prerequisite is not met, enrollment is subject to audition.)

8339 LEC 9:00 am - 9:30 am T Th LARONGA, B CH 242
AND LAB 9:30 am - 10:25 am T Th LARONGA, B CH 242

MUSIC 603 - BRASS INSTRUMENT INSTRUCTION III (UC:CSU) - 2.00 UNITS

PREREQUISITE: Music 602 with a satisfactory grade or better. The student continues brass instrument instruction with increased emphasis in all areas covered. Primary emphasis is on interpretation of more complex rhythmic notation and performance skills. Some instruments available to loan to enrolled students. (If prerequisite is not met, enrollment is subject to audition.)

8340 LEC 9:00 am - 9:30 am T Th LARONGA, B CH 242
AND LAB 9:30 am - 10:25 am T Th LARONGA, B CH 242

SECTION# TIME DAYS INSTRUCTOR LOCATION

MUSIC 604 - BRASS INSTRUMENT INSTRUCTION IV (UC:CSU) - 2.00 UNITS

PREREQUISITE: Music 603 with a satisfactory grade or better. The student continues brass instrument instruction with increased emphasis in all areas covered. Primary emphasis is on interpretation of solo and small ensemble literature. Some instruments available to loan to enrolled students. (If prerequisite is not met, enrollment is subject to audition.)

8341 LEC 9:00 am - 9:30 am T Th LARONGA, B CH 242
AND LAB 9:30 am - 10:25 am T Th LARONGA, B CH 242

MUSIC 611 - STRING INSTRUMENT INSTRUCTION I (UC:CSU) - 2.00 UNITS

The student receives basic instruction on the string instruments, either violin, viola, cello or bass. Some instruments available to loan to enrolled students. Open to all students.

8342 LEC 9:00 am - 9:30 am M W HENDERSON, L L CH 260
AND LAB 9:30 am - 10:25 am M W HENDERSON, L L CH 260

MUSIC 612 - STRING INSTRUMENT INSTRUCTION II (UC:CSU) - 2.00 UNITS

PREREQUISITE: Music 611 with a satisfactory grade or better. The student continues string instrument instruction with increased emphasis in all areas covered. Primary emphasis is on development of bow and fingering techniques and music reading skills. Some instruments available to loan to enrolled students. (If prerequisite is not met, enrollment is subject to audition.)

8343 LEC 9:00 am - 9:30 am M W HENDERSON, L L CH 260
AND LAB 9:30 am - 10:25 am M W HENDERSON, L L CH 260

MUSIC 613 - STRING INSTRUMENT INSTRUCTION III (UC:CSU) - 2.00 UNITS

PREREQUISITE: Music 612 with a satisfactory grade or better. The student continues string instrument study with increased emphasis in all areas covered. Primary emphasis is on development of bow and fingering technique in third position and music reading skills. Some instruments available to loan to enrolled students. (If prerequisite is not met, enrollment is subject to audition.)

8344 LEC 9:00 am - 9:30 am M W HENDERSON, L L CH 260
AND LAB 9:30 am - 10:25 am M W HENDERSON, L L CH 260

MUSIC 614 - STRING INSTRUMENT INSTRUCTION IV (UC:CSU) - 2.00 UNITS

PREREQUISITE: Music 613 with a satisfactory grade or better. The student learns more advanced string instrument techniques with increased emphasis in all areas covered. Primary emphasis is on interpretation of advanced solo and small ensemble literature. Some instruments available to loan to enrolled students. (If prerequisite is not met, enrollment is subject to audition.)

8345 LEC 9:00 am - 9:30 am M W HENDERSON, L L CH 260
AND LAB 9:30 am - 10:25 am M W HENDERSON, L L CH 260

MUSIC 620 - INSTRUMENTAL PRACTICE LAB - 0.50 UNITS Rpt 3

CO-REQUISITE: Either Music 101, 185, 250, 311, 312, 313, 314, 341, 351, 400, 401, 402, 403, 431, 432, 433, 501, 561, 601, 602, 603, 604, 611, 612, 613, 614, 621, 622, 623, 624, 650, 651, 652, 653, 654, 705, 711, 725, 751, 771 or 781. This course allows students currently enrolled in any of the co-requisite instrumental classes to use the lab equipment and materials to enhance applicable skills necessary for success.

8571 LAB - 1:05 hrs TBA WANNER, D A CH 206

MUSIC 621 - WOODWIND INSTRUMENT INSTRUCTION I (UC:CSU) - 2.00 UNITS

The student learns basic woodwind instrument techniques. Includes flute, oboe, clarinet, bassoon and saxophone. Some instruments available to loan to enrolled students. Open to all students.

8346 LEC 9:00 am - 9:30 am T Th POZZI, D A CH 260
AND LAB 9:30 am - 10:25 am T Th POZZI, D A CH 260

SECTION#	TIME	DAYS	INSTRUCTOR	LOCATION
----------	------	------	------------	----------

MUSIC 622 - WOODWIND INSTRUMENT INSTRUCTION II (UC:CSU) - 2.00 UNITS

PREREQUISITE: Music 621 with a satisfactory grade or better. The student learns basic woodwind instrument techniques. Includes flute, oboe, clarinet, bassoon and saxophone. Some instruments available to loan to enrolled students. Open to all students.

8347	LEC	9:00 am - 9:30 am	T Th	POZZI, D A	CH 260
AND	LAB	9:30 am - 10:25 am	T Th	POZZI, D A	CH 260

MUSIC 623 - WOODWIND INSTRUMENT INSTRUCTION III (UC:CSU) - 2.00 UNITS

PREREQUISITE: Music 622 with a satisfactory grade or better. The student learns more advanced woodwind instrument techniques with increased emphasis in all areas covered. Primary emphasis is on interpretation of more complex rhythmic notation and performance skills. Some instruments available to loan to enrolled students. (If prerequisite is not met, enrollment is subject to audition.)

8348	LEC	9:00 am - 9:30 am	T Th	POZZI, D A	CH 260
AND	LAB	9:30 am - 10:25 am	T Th	POZZI, D A	CH 260

MUSIC 624 - WOODWIND INSTRUMENT INSTRUCTION IV (UC:CSU) - 2.00 UNITS

PREREQUISITE: Music 623 with a satisfactory grade or better. The student learns more advanced woodwind instrument techniques with increased emphasis in all areas covered. Primary emphasis is on interpretation of advanced solo and small ensemble literature. Some instruments available to loan to enrolled students. (If prerequisite is not met, enrollment is subject to audition.)

8349	LEC	9:00 am - 9:30 am	T Th	POZZI, D A	CH 260
AND	LAB	9:30 am - 10:25 am	T Th	POZZI, D A	CH 260

MUSIC 631 - PERCUSSION INSTRUMENT INSTRUCTION I (UC:CSU) - 2.00 UNITS

The student learns basic rhythms, rudiments, beginning notation and meters as applied to the snare drum and related percussion instruments.

8350	LEC	1:45 pm - 2:15 pm	T Th	MITCHELL, J D	CH 204
AND	LAB	2:15pm - 3:10 pm	T Th	MITCHELL, J D	CH 204

MUSIC 632 - PERCUSSION INSTRUMENT INSTRUCTION II (UC:CSU) - 2.00 UNITS

PREREQUISITE: Music 631 with a satisfactory grade or better. The student continues with basic rhythms, rudiments, beginning notation and meters as applied to the snare drum and related percussion instruments. (If prerequisite is not met, enrollment is subject to audition.)

8351	LEC	1:45 pm - 2:15 pm	T Th	MITCHELL, J D	CH 204
AND	LAB	2:15 pm - 3:10 pm	T Th	MITCHELL, J D	CH 204

MUSIC 633 - PERCUSSION INSTRUMENT INSTRUCTION III (UC:CSU) - 2.00 UNITS

PREREQUISITE: Music 632 with a satisfactory grade or better. The student receives intermediate instruction on percussion instruments and develop greater skill in the reading of percussion notation and in the playing of drum set. (If prerequisite is not met, enrollment is subject to audition.)

5109	LEC	1:45 pm - 2:15 pm	T Th	MITCHELL, J D	CH 204
AND	LAB	2:15 pm - 3:10 pm	T Th	MITCHELL, J D	CH 204

MUSIC 634 - PERCUSSION INSTRUMENT INSTRUCTION IV (UC:CSU) - 2.00 UNITS

PREREQUISITE: Music 633 with a satisfactory grade or better. The advanced student develops greater skill in the reading of percussion notation and in the playing of drum set as it relates to contemporary funk styles. (If prerequisite is not met, enrollment is subject to audition.)

5110	LEC	1:45 pm - 2:15 pm	T Th	MITCHELL, J D	CH 204
AND	LAB	2:15 pm - 3:10 pm	T Th	MITCHELL, J D	CH 204

SECTION#	TIME	DAYS	INSTRUCTOR	LOCATION
----------	------	------	------------	----------

MUSIC 640 - ADVANCED PRACTICE LAB - INSTRUMENTAL - 0.50 UNITS Rpt 3

PREREQUISITE 620. CO-REQUISITE: Either Music 101, 185, 250, 311, 312, 313, 314, 341, 351, 400, 401, 402, 403, 431, 432, 433, 501, 561, 601, 602, 603, 604, 611, 612, 613, 614, 621, 622, 623, 624, 650, 651, 652, 653, 654, 705, 711, 725, 751, 771 or 781. The student uses departmental practice rooms to further enhance applicable skills necessary for success in the co-requisite course. For advanced students who have completed Music 620 four times.

8365	LAB	- 3:10 hrs	TBA	WANNER, D A	CH 206
------	-----	------------	-----	-------------	--------

MUSIC 650 - BEGINNING GUITAR (UC:CSU) - 2.00 UNITS

The student learns basic positioning of body and hands, music notation and reading, finger picking and chord accompaniment. Designed for students with no previous musical training. Student must provide own guitar.

0966	LEC	10:35 am - 11:05 am	T Th	SUOVANEN, C R	CH 260
AND	LAB	11:05 am - 12:00 pm	T Th	SUOVANEN, C R	CH 260
0972	LEC	9:00 am - 10:05 am	F	NEWTON, G P	CH 260
AND	LAB	10:05 am - 12:10 pm	F	NEWTON, G P	CH 260
3445	LEC	6:50 pm - 7:55 pm	T	KOZUBEK, M	CH 260
AND	LAB	7:55 pm -10:00 pm	T	KOZUBEK, M	CH 260

MUSIC 651 - CLASSICAL GUITAR I (UC:CSU) - 2.00 UNITS

PREREQUISITE: Music 650 with a satisfactory grade or better. The student reinforces fundamental music reading, right and left hand playing techniques and performance of elementary solo guitar compositions. For students who wish to continue beyond the beginning level. Student must provide own guitar. (If prerequisite is not met, enrollment is subject to audition.)

5771	LEC	6:50 pm - 7:40 pm	T	SUOVANEN, C R	CH 242
AND	LAB	7:45 pm -10:00 pm	T	SUOVANEN, C R	CH 242
8566	LEC	1:45 pm - 2:15 pm	T Th	SUOVANEN, C R	CH 242
AND	LAB	2:15 pm - 3:20 pm	T Th	SUOVANEN, C R	CH 242

MUSIC 652 - CLASSICAL GUITAR II (UC:CSU) - 2.00 UNITS

PREREQUISITE: Music 651 with a satisfactory grade or better. The student performs intermediate level exercises and solos. For students who want to progress further into more technically demanding compositions. Student must provide own guitar. (If prerequisite is not met, enrollment is subject to audition.)

5772	LEC	6:50 pm - 7:40 pm	T	SUOVANEN, C R	CH 242
AND	LAB	7:45 pm -10:00 pm	T	SUOVANEN, C R	CH 242
8590	LEC	1:45 pm - 2:15 pm	M W	SUOVANEN, C R	CH 242
AND	LAB	2:15 pm - 3:20 pm	M W	SUOVANEN, C R	CH 242

MUSIC 653 - CLASSICAL GUITAR III (UC:CSU) - 2.00 UNITS

PREREQUISITE: Music 652 with a satisfactory grade or better. The student performs compositions of greater harmonic and technical complexity. For intermediate to advanced students who wish to probe deeper into analysis and performance practices of the classical guitarist. Student must provide own guitar. (If prerequisite is not met, enrollment is subject to audition.)

5773	LEC	6:50 pm - 7:40 pm	T	SUOVANEN, C R	CH 242
AND	LAB	7:45 pm -10:00 pm	T	SUOVANEN, C R	CH 242
8591	LEC	1:45 pm - 2:15 pm	M W	SUOVANEN, C R	CH 242
AND	LAB	2:15 pm - 3:20 pm	M W	SUOVANEN, C R	CH 242

MUSIC 654 - CLASSICAL GUITAR IV (UC:CSU) - 2.00 UNITS

PREREQUISITE: Music 653 with a satisfactory or better. DESCRIPTION: The student analyzes, prepares and performs advanced compositions for classical guitar, incorporating the full range of classical guitar techniques. Musicianship and aesthetics of music are considered in depth. Ensembles of various sizes prepare and perform music from all eras.

5774	LEC	6:50 pm - 7:40 pm	T	SUOVANEN, C R	CH 242
AND	LAB	7:45 pm -10:00 pm	T	SUOVANEN, C R	CH 242
8592	LEC	1:45 pm - 2:15 pm	M W	SUOVANEN, C R	CH 242
AND	LAB	2:15 pm - 3:20 pm	M W	SUOVANEN, C R	CH 242

SECTION# TIME DAYS INSTRUCTOR LOCATION

MUSIC 705 - CHAMBER MUSIC (UC:CSU) - 1.00 UNITS Rpt 3

DESCRIPTION: This course consists of the reading, study and performance of standard chamber music repertoire with special emphasis on performance in recital of major chamber music works. (Confirmation of enrollment subject to audition.)

See "auditions" box.)

8358 LAB 1:45 pm - 3:15 pm MW PARK, C J CH 206

MUSIC 711 - REHEARSAL ORCHESTRA (UC:CSU) - 1.00 UNITS Rpt 3

DESCRIPTION: This course is planned for the player of intermediate ability and for those who wish to become more proficient on a secondary instrument. The music studied includes not only orchestral literature of an intermediate level but also places an emphasis on technical studies which will help develop the player's individual technical competence and ensemble skill. (Confirmation of enrollment is subject to audition. See "auditions" box.)

8359 LAB 12:10 pm - 1:35 pm MW HENDERSON, L L CH 260

MUSIC 725 - COMMUNITY ORCHESTRA (UC:CSU) - 1.00 UNITS Rpt 3

DESCRIPTION: This course consists of the reading, study, and performance of standard orchestral repertoire with special emphasis on performance of major orchestral works. Practical experience is also offered to capable student conductors, soloists, composers and arrangers. (Confirmation of enrollment subject to audition.)

3446 LAB 6:50 pm -10:00 pm W HENDERSON, L L CH 260

MUSIC 751 - WIND ENSEMBLE (UC:CSU) - 1.00 UNITS Rpt 3

DESCRIPTION: This course consists of the study of standard band literature with the intent to develop an individual's technical and artistic abilities through experiences with a wide range of band literature. Public performances are presented. (Confirmation of enrollment subject to audition. See "auditions" box.)

8360 LAB 12:10 pm - 1:35 pm MW HENDERSON, L L CH 260

MUSIC 771 - GUITAR ENSEMBLE (UC:CSU) - 1.00 UNITS Rpt 3

DESCRIPTION: This course consists of the study and performance of standard guitar ensemble literature with emphasis on intonation, rhythmic togetherness, balance, style, and the requirements of effective ensemble playing. (Confirmation of enrollment subject to audition. See "auditions" box.)

3447 LEC 6:50 pm -10:00 pm W SUOVANEN, C R CH 242

MUSIC 781 - STUDIO JAZZ BAND (UC:CSU) - 1.00 UNITS Rpt 3

DESCRIPTION: Provides training and experience in the various aspects of technique and interpretation as applied to jazz band performance. Includes public performance and recording experience. For intermediate to advanced players. (Confirmation of enrollment is subject to audition. See "auditions" box.)

0968 LEC 1:45 pm - 2:15 pm T Th STUNTZ, L A CH 260
AND LAB 2:15 pm - 3:40 pm T Th STUNTZ, L A CH 260

MUSIC 820 - PERCUSSION PRACTICE LAB - 0.50 UNITS Rpt 3

CO-REQUISITE: Either Music 631, 632, 633, 634 or 765. DESCRIPTION: This course allows students currently enrolled in any of the co-requisite percussion classes to use the lab equipment and materials to enhance applicable skills necessary for success.

8573 LAB - 3:10 hrs TBA WANNER, D A CH 206

MUSIC 840 - ADVANCED PRACTICE LAB - PERCUSSION - 0.50 UNITS Rpt 3

PREREQUISITE: Music 820. Corequisite: Music 631 or 632 or 633 or 634 or 765. The student uses departmental percussion practice rooms to further enhance applicable skills necessary for success in the co-requisite course. For advanced students who have completed Music 820 four times.

8367 LAB - 3:10 hrs TBA WANNER, D A CH 206

MUSIC 931 - COOPERATIVE EDUCATION - MUSIC (CSU) - 3.00 UNITS Rpt 3

9102 - 3:10 hrs TBA WERBLE, D M AD 209

SECTION# TIME DAYS INSTRUCTOR LOCATION

MUSIC 941 - COOPERATIVE EDUCATION - MUSIC (CSU) - 4.00 UNITS Rpt 3

9103 - 4:15 hrs TBA WERBLE, D M AD 209

OCEANOGRAPHY

Chair: John Fraitas, SCI324B (323) 953-4000 ext 2600
<http://www.lacitycollege.edu/academic/departments/chemistry/>

OCEANOGRAPHY 001 - INTRODUCTION TO OCEANOGRAPHY (UC:CSU) - 3.00 UNITS

ADVISORY: Eligibility English 28 and 67 or equivalent. The student receives a general introduction to the origin of the universe, plate tectonics, ocean basins, water, beaches, tides, and the overall uses and abuses of the ocean by human beings.

1597 LEC 9:00 am - 10:25 am MW O BOYLE, C L SCI 200

PERSONAL DEVELOPMENT

Chair: Reri N. Pumphrey, AD 108 (323) 953-4000 ext 2250
<http://catalog.lacitycollege.edu/pages/personal/development.html>

PERSONAL DEVELOPMENT 020 - POST SECONDARY EDUCATION: THE SCOPE OF CAREER PLANNING (CSU) - 3.00 UNITS

ADVISORY: English 28 or equivalent. DESCRIPTION: This course is designed to assist students with self-exploration, career transitions, career-life planning and employment readiness skills in order to achieve success in a diverse society. Critical thinking skills will be utilized through a systematic approach to career development by examining values, interests, skills, life roles, personality type, personal self-management, decision-making and goal-setting throughout the life span through the use of career assessment and various other introspective activities.

1055 LEC 9:00 am - 10:25 am MW NISSIM, A HH 205
1060 LEC 12:10 pm - 1:35 pm MW SOTO, C L AD 309

PERSONAL DEVELOPMENT 040 - COLLEGE SUCCESS SEMINAR (UC:CSU) - 3.00 UNITS

ADVISORY: English 28 or equivalent. DESCRIPTION: This course will explore issues related to higher education that impact student success. Topics will include an overview of academic success skills, value and purpose of higher education, Los Angeles City College and Los Angeles Community District policies and procedures, ethics and responsibility, diversity in higher education, educational strategies and planning, interpersonal communication, career development, health issues, and self-assessment techniques.

1056 LEC 10:35 am - 12:00 pm T Th SOTO, C L AD 306
1057 LEC 9:00 am - 10:25 am T Th SOTO, C L AD 309
1058 LEC 9:00 am - 10:25 am MW SOTO, C L AD 203
1059 LEC 10:35 am - 12:00 pm MW SOTO, C L AD 306
1061 LEC 12:10 pm - 1:35 pm T Th SANCHEZ, R E AD 306

PHILOSOPHY

Chair: Michael Critelli, HH200B (323) 953-4000 ext 2761
<http://catalog.lacitycollege.edu/pages/philosophy.html>

PHILOSOPHY 001 - INTRODUCTION TO PHILOSOPHY (UC:CSU) - 3.00 UNITS

ADVISORY: English 28 or equivalent. DESCRIPTION: The following questions and their relevance to our daily lives will be discussed: Does life have meaning? Does God exist? Do we possess free will? What is truth? What is the good life?

1067 LEC 7:25 am - 8:50 am MW LOPEZ, C J HH 202
1068 LEC 7:25 am - 8:50 am T Th STAFF HH 206
1069 LEC 9:00 am - 10:25 am MW CRITELLI, M J FH 117
TORRES, J
1070 LEC 9:00 am - 10:25 am T Th TORRES, J HH 202
1071 LEC 10:35 am - 12:00 pm MW CRITELLI, M J FH 117
TORRES, J
1081 LEC 9:00 am - 10:25 am MW CRITELLI, M J HH 6
TORRES, J
1084 LEC 10:35 am - 12:00 pm MW CRITELLI, M J FH 117

SECTION#	TIME	DAYS	INSTRUCTOR	LOCATION
			TORRES, J	
3032	LEC	6:50 pm -10:00 pm	Th	HH 206
3483	LEC	3:30 pm - 6:40 pm	T	HH 202
5127	LEC	3:30 pm - 6:40 pm	Th	HH 202
5129	LEC	6:50 pm -10:00 pm	W	HH 206
8292	LEC	9:00 am - 10:25 am	T Th	HH 202
8439	LEC	12:10 pm - 1:35 pm	M W	HH 202

PHILOSOPHY 006 - LOGIC IN PRACTICE (UC:CSU) - 3.00 UNITS

ADVISORY: English 28 DESCRIPTION: This course in critical thinking is intended to develop understanding of logical principles and their application to everyday life in such areas as advertising, newspapers, etc.

1079	LEC	9:00 am - 10:25 am	M W	LOPEZ, C J	HH 202
3034	LEC	6:50 pm -10:00 pm	M	TORRES, J	HH 202

PHILOSOPHY 008 - DEDUCTIVE LOGIC (UC:CSU) - 3.00 UNITS

ADVISORY: English 28. DESCRIPTION: This introductory logic class, which is open to all students, is designed to develop the student's ability to think critically and to reason correctly. Attention will be given to both formal and informal logic.

1076	LEC	9:00 am - 10:25 am	T Th	STAFF	HH 206
------	-----	--------------------	------	-------	--------

PHILOSOPHY 009 - SYMBOLIC LOGIC I (UC:CSU) - 3.00 UNITS

The student learns to translate, analyze and evaluate arguments in modern symbolic logic by employing the principles and methods of proportional and predicate logic.

3023	LEC	3:30 pm - 6:40 pm	M	TORRES, J	HH 206
------	-----	-------------------	---	-----------	--------

PHILOSOPHY 014 - HISTORY OF MODERN EUROPEAN PHILOSOPHY (UC:CSU) - 3.00 UNITS

DESCRIPTION: This class traces the development of the ideas which shape the modern mind. The individual's relationship to the state, to his fellow human beings and to the universe will be explored in the works of modern philosophers.

1073	LEC	10:35 am - 12:00 pm	T Th	TORRES, J	HH 202
8288	LEC	10:35 am - 12:00 pm	T Th	TORRES, J	HH 202

PHILOSOPHY 020 - ETHICS (UC:CSU) - 3.00 UNITS

ADVISORY: English 28. DESCRIPTION: This course offers a study of historical and contemporary ethical theories as well as a discussion of contemporary moral issues.

1078	LEC	10:35 am - 12:00 pm	T Th	STAFF	HH 206
------	-----	---------------------	------	-------	--------

PHILOSOPHY 032 - PHILOSOPHY OF RELIGION (UC:CSU) - 3.00 UNITS

DESCRIPTION: Offers an exposition, discussion and analysis of significant philosophical questions which have been directed at religious beliefs.

1074	LEC	12:10 pm - 1:35 pm	M W	TORRES, J	HH 202
------	-----	--------------------	-----	-----------	--------

PHILOSOPHY 040 - INTRODUCTION TO THE PHILOSOPHY OF ART (UC:CSU) - 3.00 UNITS

ADVISORY: English 28. DESCRIPTION: Various philosophical theories regarding the nature of art, 'beauty' and the aesthetic experience will be examined in this class.

1082	LEC	10:35 am - 12:00 pm	M W	LOPEZ, C J	HH 202
------	-----	---------------------	-----	------------	--------

PHOTOGRAPHY

Chair: Daniel Marlos, CHEM BASEMENT (323) 953-4000 ext. 2835
<http://www.lacitycollege.edu/academic/departments/medarts/photo/index.html>

PHOTOGRAPHY 001 - ELEMENTARY PHOTOGRAPHY (CSU) - 6.00 UNITS

PREREQUISITE: Photography 10 with satisfactory grade or better, or approval of B&W portfolio by instructor prior to enrollment. First meeting of the semester is a lecture class. ADVISORY: Photography 28 and English 28 or equivalent. DESCRIPTION: DO NOT attend Lab class. This is the first class in the degree program. An intense continuation of Photo 10 with emphasis on professional view camera, studio lighting

SECTION#	TIME	DAYS	INSTRUCTOR	LOCATION
1088	LEC	9:00 am - 12:10 pm	Th	MARLOS, D J CHEM 3
AND	LAB	9:00 am - 12:10 pm	T	MARLOS, D J CHEM BASE
AND	LAB	9:00 am - 12:05 pm	W	MARLOS, D J CHEM BASE
AND	LAB	9:00 am - 12:10 pm	F	MARLOS, D J CHEM BASE

PHOTOGRAPHY 007 - EXPLORING DIGITAL PHOTOGRAPHY - 3.00 UNITS

ADVISORY: English 28/31 or equivalent. DESCRIPTION: An introductory course in the uses and applications of professional digital SLR cameras. Camera controls, elements of composition, and photographing with natural light will be stressed. Professional digital cameras may be provided by the department for student use. Students may use their own cameras to supplement assignments. Owning a digital camera is not a requirement but is highly recommended.

1090	LEC	9:00 am - 12:10 pm	S	TSAI, M C	CC 147
3494	LEC	6:50 pm -10:00 pm	M	OLIVER, A S	CC 147

PHOTOGRAPHY 010 - BEGINNING PHOTOGRAPHY (UC:CSU) - 3.00 UNITS

ADVISORY: English 28/31 or equivalent. DESCRIPTION: Basic principles of photography from the mechanical creation of the image with camera and film to enlarging the photograph for display, while applying the guidelines of composition, communication and self-expression. 35 mm single lens camera required. Automatic cameras are OK, but they must have manual shutter speed and lens opening capability. Approximate supplies cost is \$125. You must attend the first lecture meeting, or be replaced by students wishing to add. The first scheduled class is the first lecture meeting. Do not attend the first lab meeting. Labs will met only after announced in lecture class.

1086	LEC	1:15 pm - 3:20 pm	W	OKAMURA, L N	CHEM 3
AND	LAB	12:10 pm - 3:20 pm	M	OKAMURA, L N	CHEM BASE
1089	LEC	9:00 am - 11:05 am	T	OKAMURA, L N	CHEM 3
AND	LAB	12:10 pm - 3:20 pm	T	OKAMURA, L N	CHEM BASE
1096	LEC	9:00 am - 11:05 am	F	LUTZ, S C	CHEM 3
AND	LAB	12:10 pm - 3:20 pm	F	LUTZ, S C	CHEM BASE
3005	LEC	8:10 pm -10:00 pm	T	NELSON, K L	CHEM 3
AND	LAB	5:00 pm - 8:00 pm	T	NELSON, K L	CHEM BASE

PHOTOGRAPHY 015 - FUNDAMENTALS OF PORTRAITURE (CSU) - 3.00 UNITS

PREREQUISITE: Photography 1. ADVISORY: Concurrent enrollment in Photography 28. DESCRIPTION: Lecture, 2 hours; laboratory, 3 hours. This course offers a study of modern photographic lightings in portraiture, using professional cameras and lighting equipment. Photographic films, exposure factors, developing techniques, and print display are presented. Lightings for groups, environmental portraiture and posting techniques are studied as well.

3038	LEC	8:00 pm -10:10 pm	Th	MARLOS, D J	CHEM 3
AND	LAB	5:00 pm - 7:50 pm	Th	MARLOS, D J	CHEM BASE

PHOTOGRAPHY 028 - LABORATORY PROCESSES - 1.00 UNITS Rpt 3

ADVISORY: English 28/31 with a satisfactory grade or better. DESCRIPTION: Register for, but DO NOT attend this class until you are advised to do so by the instructor of your primary Photography class (such as Photo 10 or Photo 1).

0340	LAB	12:10 pm - 3:20 pm	T	OKAMURA, L N	CHEM BASE
1443	LAB	12:10 pm - 3:20 pm	M	OKAMURA, L N	CHEM BASE
1444	LAB	9:00 am - 12:10 pm	T	MARLOS, D J	CHEM BASE
1446	LAB	9:00 am - 12:10 pm	W	MARLOS, D J	CHEM BASE
1449	LAB	12:10 pm - 3:20 pm	Th	MARLOS, D J	CHEM BASE
1451	LAB	9:00 am - 12:10 pm	F	MARLOS, D J	CHEM BASE
1456	LAB	12:10 pm - 3:20 pm	F	LUTZ, S C	CHEM BASE
3055	LAB	5:00 pm - 8:10 pm	T	NELSON, K L	CHEM BASE
3039	LAB	5:00 pm - 8:05 pm	Th	MARLOS, D J	CHEM BASE

SECTION#	TIME	DAYS	INSTRUCTOR	LOCATION
----------	------	------	------------	----------

PHOTOGRAPHY 033 - ADVANCED LABORATORY PROCESSES - 1.00 UNITS Rpt 3

PREREQUISITE: Photography 28 with a satisfactory grade or better. COREQUISITE: Photography 15 or 22 or 3 or 6. ADVISORY: English 28/31. DESCRIPTION: This course will concentrate on lab instruction designed to familiarize students with safety factors and the technology of film and paper processes.

8453	LAB	- 3:10 hrs	TBA	MARLOS, D J	CHEM BASE
------	-----	------------	-----	-------------	-----------

PHOTOGRAPHY 034 - HISTORY OF PHOTOGRAPHY (UC:CSU) - 3.00 UNITS

ADVISORY: English 28 and 67 or equivalent. Students recognize and identify the major historical developments of in photography including major technological inventions and advancements, styles and movements, and important photographers from 1826 though 1960. Special attention is paid to the impact of the photographic image and how it has shaped modern art and culture worldwide.

1498	LEC	12:10 pm - 3:30 pm	T	LUTZ, S C	CHEM 3
------	-----	--------------------	---	-----------	--------

PHOTOGRAPHY 046 - PHOTOGRAPHIC DIGITAL IMAGING - 3.00 UNITS

Art and cinema majors: please see instructor prior to enrollment. ADVISORY: English 28/31 or equivalent. DESCRIPTION: This digital imaging course incorporates the use of computers and photo digitizing software to alter, enhance, and create new images that can be output to film and print media.

1097	LEC	9:35 am - 11:45 am	F	OKAMURA, L N	CC 147
AND	LAB	12:10 pm - 3:30 pm	F	OKAMURA, L N	CC 147

PHOTOGRAPHY 050 - SPECIALTY FIELDS - 3.00 UNITS Rpt 3

PREREQUISITE: Photography 1 or 207 with a satisfactory grade or instructor's approval of advanced level portfolio. DESCRIPTION: An independent study course designed to create a photography portfolio. This class is designed for advanced students and gives special attention to their individual concepts and goals.

0237	LAB	- 10:05 hrs	TBA	OKAMURA, L N	CHEM BASE
8462	LAB	- 10:00 hrs	TBA	MARLOS, D J	CHEM BASE

PHOTOGRAPHY 107 - INTERMEDIATE DIGITAL PHOTOGRAPHY - 3.00 UNITS

PREREQUISITE: Photo 7 and Photo 46. DESCRIPTION: An in-depth course in the workflow of professional digital photography. RAW capture, processing, color management, archiving, transferring files, and printing will be stressed. Students will also explore studio lighting using tungsten lights and will develop a portfolio demonstrating technical and aesthetic proficiency. A limited number of professional digital cameras may be provided by the department for student usage. Owning a digital SLR camera is not a requirement but is highly recommended.

3458	LEC	7:55 pm - 10:00 pm	W	OLIVER, A S	CC 147
AND	LAB	5:00 pm - 7:55 pm	W	OLIVER, A S	CC 147

PHYSICAL EDUCATION

Chair: John Erdhaus, MG104 (323) 953-4000 ext 2851,

<http://www.lacitycollege.edu/academic/departments/pe/index.html>

EDUCATION 101 - SWIMMING-NON/SWIMMER (UC:CSU) - 1.00 UNITS Rpt 3

Advisory: Eligibility in English 28 or its equivalent or concurrent enrollment in LS 1, 7, and Speech 113.

2010	LAB	9:25 am - 10:30 am	M W	MCEVEETY, J S	MG POOL
2901	LAB	3:30 pm - 5:35 pm	W	COULEHAN, M E	MG POOL

PHYSICAL EDUCATION 102 - SWIMMING SKILLS (UC:CSU) - 1.00 UNITS Rpt 3

Students learn swimming skills. Skills for each stroke include kicking, arm stroke, proper breathing techniques, body position, and rhythm of stroke. The student will also learn water safety skills.

2100	LAB	9:25 am - 10:30 am	M W	MCEVEETY, J S	MG POOL
2103	LAB	9:25 am - 10:25 am	T Th	MCEVEETY, J S	MG POOL

SECTION#	TIME	DAYS	INSTRUCTOR	LOCATION
----------	------	------	------------	----------

2106	LAB	2:30 pm - 4:35 pm	M	MCEVEETY, J S	MG POOL
2110	LAB	10:10 am - 12:15 pm	S	RIVERA, L R	MG POOL
2131	LAB	7:50 am - 8:50 am	M W	MCEVEETY, J S	MG POOL
2944	LAB	3:30 pm - 5:35 pm	W	COULEHAN, M E	MG POOL

PHYSICAL EDUCATION 110 - LAP SWIMMING FOR FITNESS (UC:CSU) - 1.00 UNITS Rpt 3

2101	LAB	10:35 am - 11:35 am	M W	MCEVEETY, J S	MG POOL
2102	LAB	7:30 am - 8:30 am	T Th	TINBERG, C	MG POOL
9108	LAB	8:00 am - 10:05 am	S	RIVERA, L R	MG POOL

PHYSICAL EDUCATION 122 - AQUA EXERCISE (UC:CSU) - 1.00 UNITS Rpt 3

2112	LAB	1:30 pm - 2:30 pm	T Th	MCEVEETY, J S	MG POOL
------	-----	-------------------	------	---------------	---------

PHYSICAL EDUCATION 170 - WALKING FOR FITNESS (UC:CSU) - 1.00 UNITS Rpt 3

2122	LAB	9:00 am - 10:00 am	T Th	CAIRNS, N J	WG 107
------	-----	--------------------	------	-------------	--------

PHYSICAL EDUCATION 185 - DIRECTED STUDY - PHYSICAL EDUCATION (GSU) - 1.00 UNITS Rpt 2

2001	LEC	- 1:05 hrs	TBA	ERDHAUS, J F	MG 104
5139	LEC	- 1:00 hrs	TBA	MCEVEETY, J S	WG 204
5140	LEC	- 1:00 hrs	TBA	GLICKMAN, D C	WG 204

PHYSICAL EDUCATION 203 - BADMINTON SKILLS (UC:CSU) - 1.00 UNITS Rpt 3

2473	LAB	12:40 pm - 1:40 pm	M W	GLICKMAN, D C	WG 107
------	-----	--------------------	-----	---------------	--------

PHYSICAL EDUCATION 212 - TENNIS SKILLS (UC:CSU) - 1.00 UNITS Rpt 3

Classes meet FIRST TWO weeks at WG 102C. Thereafter at Griffith Park (courts next to the merry-go-round.)

2105	LAB	9:45 am - 11:50 am	Th	GLICKMAN, D C	GRIF PARK
------	-----	--------------------	----	---------------	-----------

PHYSICAL EDUCATION 219 - TABLE TENNIS SKILLS (UC:CSU) - 1.00 UNITS Rpt 3

2474	LAB	2:10 pm - 4:20 pm	W	GLICKMAN, D C	WG 107
------	-----	-------------------	---	---------------	--------

PHYSICAL EDUCATION 225 - YOGA SKILLS (UC:CSU) - 1.00 UNITS Rpt 3

2120	LAB	8:00 am - 10:05 am	S	COULEHAN, M E	WG 202
2121	LAB	10:30 am - 12:35 pm	S	COULEHAN, M E	WG 202
2124	LAB	10:10 am - 12:15 pm	F	ECKLER, P	WG 206
2155	LAB	12:45 pm - 1:35 pm	M W	ECKLER, P	WG 202
2184	LAB	10:45 am - 12:50 pm	M W	GLICKMAN, D C	WG 202

(8 Week Class - Starts 8/30/2010, Ends 10/20/2010)

2185	LAB	10:45 am - 12:50 pm	M W	GLICKMAN, D C	WG 206
------	-----	---------------------	-----	---------------	--------

(8 Week Class - Starts 10/25/2010, Ends 12/19/2010)

2241	LAB	2:30 pm - 4:30 pm	W	JENSEN, K L	WG 206
2910	LAB	4:30 pm - 6:35 pm	T	CUMMINS, D J	WG 202
2912	LAB	6:50 pm - 8:55 pm	Th	CUMMINS, D J	WG 202
2913	LAB	4:30 pm - 6:35 pm	Th	CUMMINS, D J	WG 202

PHYSICAL EDUCATION 228 - BODY CONDITIONING (UC:CSU) - 1.00 UNITS Rpt 3

2008	LAB	9:30 am - 10:30 am	M W	TINBERG, C	WG 107
2178	LAB	8:00 am - 10:10 am	F	ECKLER, P	WG 202
2955	LAB	6:50 pm - 8:55 pm	W	COULEHAN, M E	WG 202

SECTION#	TIME	DAYS	INSTRUCTOR	LOCATION
----------	------	------	------------	----------

PHYSICAL EDUCATION 230 - WEIGHT TRAINING SKILLS (UC:CSU) - 1.00 UNITS Rpt 3

Students develop flexibility, muscular strength, muscular endurance, and cardiovascular endurance. Students learn the proper techniques to utilize in their personal fitness later in life, to achieve a healthier lifestyle.

2051	LAB	6:35 am - 7:35 am	M W	ROUSEY, S M	MG 108
2052	LAB	7:50 am - 8:50 am	M W	COWGILL, D P	MG 108
2054	LAB	10:35 am - 11:35 am	M W	CANO, T D	MG 108
2114	LAB	10:35 am - 11:35 am	T Th	CAIRNS N J	MG 108
2129	LAB	10:00 am - 12:05 pm	F	DIETRICH, J E	MG 108
2927	LAB	5:10 pm - 6:10 pm	M W	SECK, S E	MG 108

PHYSICAL EDUCATION 238 - SELF-DEFENSE SKILLS (UC:CSU) - 1.00 UNITS Rpt 3

2134	LAB	7:45 am - 8:45 am	M W	NISHIOKA, H H	MG 106
------	-----	-------------------	-----	---------------	--------

PHYSICAL EDUCATION 241 - JUDO SKILLS (UC:CSU) - 1.00 UNITS Rpt 3

2135	LAB	12:45 pm - 1:50 pm	M W	NISHIOKA, H H	MG 106
2183	LAB	1:30 pm - 2:30 pm	T Th	NISHIOKA, H H	MG 106
2900	LAB	6:50 pm - 8:55 pm	W	SECK, S E	MG 106

PHYSICAL EDUCATION 259 - GOLF SKILLS (UC:CSU) - 1.00 UNITS Rpt 3

Students learn the fundamental techniques and skill, rules, terminology and etiquette of golf.

2167	LAB	9:30 am - 11:00 am	M W	ERDHAUS, J F	DRIV RANG
2170	LAB	8:00 am - 9:30 am	M W	ERDHAUS, J F	DRIV RANG
2195	LAB	9:35 am - 11:00 am	T Th	ERDHAUS, J F	DRIV RANG
2197	LAB	8:00 am - 9:30 am	T Th	ERDHAUS, J F	DRIV RANG

PHYSICAL EDUCATION 262 - TRACK AND FIELD SKILLS (UC:CSU) - 1.00 UNITS Rpt 3

2009	LAB	8:00 am - 9:00 am	T Th	CAIRNS, N J	FIEL D
2139	LAB	9:35 am - 10:40 am	T Th	CANO, T D	FIEL D

PHYSICAL EDUCATION 299 - STRESS MANAGEMENT TECHNIQUES THROUGH MOVEMENT (UC:CSU) - 1.00 UNITS Rpt 3

2172	LAB	10:35 am - 12:40 pm	F	SINGER, L	WG 202
2904	LAB	6:50 pm - 8:55 pm	M	SINGER, L	WG 202

PHYSICAL EDUCATION 304 - BASKETBALL SKILLS (UC:CSU) - 1.00 UNITS Rpt 3

Instruction and practice in the fundamental skills of basketball and in offensive and defensive game strategies. Co-educational participation in drills and competition.

2107	LAB	10:35 am - 11:35 am	M W	TINBERG, C	WG 107
2246	LAB	9:25 am - 10:25 am	T Th	TINBERG, C	WG 107

PHYSICAL EDUCATION 313 - SOCCER SKILLS (UC:CSU) - 1.00 UNITS Rpt 3

2003	LAB	10:30 am - 11:35 am	T Th	CANO, T D	FIEL D
------	-----	---------------------	------	-----------	--------

PHYSICAL EDUCATION 322 - VOLLEYBALL SKILLS (UC:CSU) - 1.00 UNITS Rpt 3

Students learn volleyball skills and techniques. Skills learned are passing, setting, serving, hitting and blocking. The students also learn strategy used for games and rules of the sport.

2143	LAB	11:00 am - 12:00 pm	T Th	MCEVEETY, J S	WG 107
2919	LEC	6:50 pm - 8:55 pm	W	RIVERA, L R	WG 107

PHYSICAL EDUCATION 630 - AEROBIC SUPER CIRCUIT LABORATORY (UC:CSU) - 1.00 UNITS Rpt 3

NEW STUDENTS: If you are taking PE630 FOR THE FIRST TIME, enroll in one of the orientation sections below. Sections meet one time only on the date indicated. The remainder of the course requirements are met by completing exercise sessions in the

SECTION#	TIME	DAYS	INSTRUCTOR	LOCATION
----------	------	------	------------	----------

Fitness Center at a time that fits your schedule and by taking a final exam. After the orientation, you can exercise ANYTIME we are open. Additional orientations might be given during the second week of the semester ONLY. You will not be allowed to exercise until you have completed your orientation. The remainder of the course requirements are met by exercising in the Fitness Center and by taking a written exam. OPEN HOURS: MTWTh 7:30 am - 12:30 pm; 4:00 pm - 6:00 pm REPEATING STUDENTS: If you have already taken and passed the class, you do not need to attend an Orientation. Enroll in any section and begin exercising.

2249	LAB	9:25 am - 10:25 am	M W	GLICKMAN, D C	WG 109
2250	LAB	12:10 pm - 1:10 pm	M W	TINBERG, C	WG 109
2251	LAB	7:00 am - 8:00 am	T Th	BECKTEL, W R	WG 109
2252	LAB	10:35 am - 11:35 am	T Th	TINBERG, C	WG 109
2255	LAB	8:00 am - 9:00 am	M W	KING, G R	WG 109
2859	LAB	1:30 pm - 3:40 pm	M W	TINBERG, C	WG 109

(8 Week Class - Starts 10/25/2010, Ends 12/19/2010)

2957	LAB	4:30 pm - 5:30 pm	M W	GLICKMAN, D C	WG 109
2958	LAB	5:30 pm - 6:30 pm	M W	GLICKMAN, D C	WG 109
2960	LAB	6:00 pm - 7:00 pm	T Th	LI, R J	WG 109
2961	LAB	4:45 pm - 5:45 pm	T Th	HERMINA, W	WG 109

PHYSICAL EDUCATION 640 - BEGINNING LIFELONG FITNESS LABORATORY (UC:CSU) - 1.00 UNITS Rpt 3

Students develop flexibility, muscular strength, muscular endurance, cardiovascular endurance, and body composition. Students learn how to achieve a healthy lifestyle and proper fitness balance.

2162	LAB	7:30 am - 9:00 am	T Th	ROUSEY, S M	MG 108
2166	LAB	9:00 am - 10:30 am	M W	COWGILL, D P	MG 108

PHYSICAL EDUCATION 642 - ADAPTED FITNESS (UC:CSU) - 1.00 UNITS Rpt 3

2247	LAB	- 3:10 hrs	TBA	TINBERG, C	WG 109
------	-----	------------	-----	------------	--------

PHYSICS

Chair: Jayesh Bhakta, SCI222D (323) 953-4000 ext 2923
<http://www.lacitycollege.edu/academic/departments/physics>

PHYSICS 006 - GENERAL PHYSICS I (UC:CSU) - 4.00 UNITS

ADVISORY: English 28 or equivalent. DESCRIPTION: This course designed for majors in Health and Life Sciences, Architecture, and all those needing a one-year course in college physics requiring trigonometry but not calculus. The principal topics are mechanics, heat and sound.

0342	LEC	12:10 pm - 3:20 pm	T	PILAPIL, Y A	SCI 216
AND	LEC	12:10 pm - 3:20 pm	Th	PILAPIL, Y A	SCI 216

PHYSICS 011 - INTRODUCTORY PHYSICS (UC:CSU) - 4.00 UNITS

PREREQUISITE: Mathematics 115, 120. ADVISORY: Eligibility to enroll in English 28. DESCRIPTION: Principles and problem solving methods forming a solid foundation for all further study of physics.

1111	LEC	12:10 pm - 3:20 pm	T	ERICKSON, R W	SCI 208
AND	LAB	12:10 pm - 3:20 pm	Th	ERICKSON, R W	SCI 208

Special tutorial assistance available to students in section 1111.

3503	LEC	6:50 pm - 10:00 pm	M	ZUNIGA-ARAGON, L	SCI 208
AND	LAB	6:50 pm - 10:00 pm	W	ZUNIGA-ARAGON, L	SCI 208
8460	LEC	12:10 pm - 3:20 pm	T	ERICKSON, R W	SCI 208
AND	LAB	12:10 pm - 3:20 pm	Th	ERICKSON, R W	SCI 208

PHYSICS 021 - GENERAL PHYSICS I WITH CALCULUS (UC:CSU) - 4.00 UNITS

PREREQUISITE: Physics 11 or high school physics. CO-REQUISITE: Mathematics 261. ADVISORY: English 28 or equivalent. DESCRIPTION: This course uses calculus to analyze and solve problems in mechanics, heat and geometrical optics.

3504	LEC	6:50 pm - 10:00 pm	T	EAGLE, R J	SCI 216
AND	LAB	6:50 pm - 10:00 pm	Th	EAGLE, R J	SCI 216

SECTION#	TIME	DAYS	INSTRUCTOR	LOCATION
PHYSICS 101 - PHYSICS FOR ENGINEERS AND SCIENTISTS I (UC:CSU) - 5.00 UNITS				

PREREQUISITE: Physics 11 with a satisfactory grade or high school physics. CO-REQUISITE: Mathematics 261. ADVISORY: English 28/31 or equivalent. DESCRIPTION: This course is designed to cover the field of mechanics, including both static and dynamics, Newton's laws, translational and rotational motion, work and energy, elasticity, fluid mechanics, simple harmonic motion, and gravitational theory.

1107	LEC	12:10 pm - 1:35 pm	M W	BHAKTA, J	SCI 208
AND	LAB	1:45 pm - 3:10 pm	M W	BHAKTA, J	SCI 208
AND	LAB	3:20 pm - 4:45 pm	M W	BHAKTA, J	SCI 208
3501	LEC	5:25 pm - 6:50 pm	T Th	MCCUDDEN, P J	SCI 208
AND	LAB	7:00 pm - 8:25 pm	T Th	MCCUDDEN, P J	SCI 208
AND	LAB	8:35 pm -10:00 pm	T Th	MCCUDDEN, P J	SCI 208

SECTION#	TIME	DAYS	INSTRUCTOR	LOCATION
PHYSICS 102 - PHYSICS FOR ENGINEERS AND SCIENTISTS II (UC:CSU) - 5.00 UNITS				

PREREQUISITE: Physics 101 with a satisfactory grade or equivalent. CO-REQUISITE: Concurrent enrollment in Mathematics 262, unless taken previously. DESCRIPTION: Physics 102 is only offered in the daytime in the Spring.

3502	LEC	5:25 pm - 6:50 pm	M W	LEE, A	SCI 216
AND	LAB	7:00 pm - 8:25 pm	M W	LEE, A	SCI 216
AND	LAB	8:35 pm -10:00 pm	M W	LEE, A	SCI 216

SECTION#	TIME	DAYS	INSTRUCTOR	LOCATION
PHYSICS 103 - PHYSICS FOR ENGINEERS AND SCIENTISTS III (UC:CSU) - 5.00 UNITS				

PREREQUISITE: Physics 102. CO-REQUISITE: Mathematics 263, unless previously taken. DESCRIPTION: Physics 103 only offered in the evening in the Spring.

1108	LEC	12:10 pm - 1:35 pm	M W	ARVIDSON, D	SCI 216
AND	LAB	1:45 pm - 3:10 pm	M W	ARVIDSON, D	SCI 216
AND	LAB	3:20 pm - 4:45 pm	M W	ARVIDSON, D	SCI 216

SECTION#	TIME	DAYS	INSTRUCTOR	LOCATION
PHYSICS 185 - DIRECTED STUDY - PHYSICS (CSU) - 1.00 UNITS Rpt 2				

Allow students to pursue Directed Study on a contract basis under the direction of a supervising instructor.

8488	LEC	- 1:00 hrs	TBA	BHAKTA, J	SCI 216
------	-----	------------	-----	-----------	---------

SECTION#	TIME	DAYS	INSTRUCTOR	LOCATION
PHYSICS 285 - DIRECTED STUDY - PHYSICS (CSU) - 2.00 UNITS				

PREREQUISITE: Please consult with the instructor.

8489	LEC	- 2:05 hrs	TBA	BHAKTA, J	SCI 216
------	-----	------------	-----	-----------	---------

SECTION#	TIME	DAYS	INSTRUCTOR	LOCATION
PHYSICS 385 - DIRECTED STUDY - PHYSICS (CSU) - 3.00 UNITS				

PREREQUISITE: Please consult with the instructor.

8490	LEC	- 3:10 hrs	TBA	BHAKTA, J	SCI 216
------	-----	------------	-----	-----------	---------

PHYSIOLOGY

Chair: Greg Gonsalves, SCI222E (323) 953-4000 ext. 2796
<http://www.lacitycollege.edu/academic/departments/lifesci/index.html>

SECTION#	TIME	DAYS	INSTRUCTOR	LOCATION
PHYSIOLOGY 001 - INTRODUCTION TO HUMAN PHYSIOLOGY (UC:CSU) - 4.00 UNITS				

PREREQUISITE: Anatomy 1. ADVISORY: English 21 or its equivalent. DESCRIPTION: For pre-nursing, radiation technology, medical techs, pre-professional students and allied health students. Students may be required to purchase or provide laboratory instructional materials. Presents general principles of physiology with special emphasis upon the human body.

1115	LEC	10:35 am - 12:00 pm	M W	GONSALVES, G G	SCI 130
AND	LAB	12:10 pm - 3:20 pm	W	GONSALVES, G G	SCI 114
Special tutorial assistance available to students in section 1115.					
1116	LEC	10:35 am - 12:00 pm	M W	GONSALVES, G G	SCI 130
AND	LAB	7:15 am - 10:25 am	Th	GONSALVES, G G	SCI 114
1117	LEC	10:35 am - 12:00 pm	T Th	GONSALVES, G G	SCI 114
AND	LAB	7:15 am - 10:25 am	T	GONSALVES, G G	SCI 114
3508	LEC	3:30 pm - 6:40 pm	T	ARAI, V E	SCI 114
AND	LAB	3:30 pm - 6:40 pm	Th	ARAI, V E	SCI 114

SECTION#	TIME	DAYS	INSTRUCTOR	LOCATION	
5136	LEC	6:50 pm -10:00 pm	W	KHOLLESI, K	SCI 130
AND	LAB	6:50 pm -10:00 pm	M	KHOLLESI, K	SCI 114
5137	LEC	6:50 pm -10:00 pm	W	KHOLLESI, K	SCI 130
AND	LAB	6:50 pm -10:00 pm	T	KHOLLESI, K	SCI 114
8487	LEC	8:00 am - 11:10 am	F	KHOLLESI, K	SCI 130
AND	LAB	12:00 pm - 3:10 pm	F	KHOLLESI, K	SCI 114

POLITICAL SCIENCE

Chair: Wendel Eckford, FH219E (323) 953-4000 ext. 2561
<http://www.lacitycollege.edu/citymain/academic.html#SUBJECT/AREA>

SECTION#	TIME	DAYS	INSTRUCTOR	LOCATION
POLITICAL SCIENCE 001 - THE GOVERNMENT OF THE UNITED STATES (UC:CSU) - 3.00 UNITS				

Students study the U.S. Constitution and the major principles, institutions and policies of the American Federal system. Meets Associate in Arts degree requirements in U. S. History. and U.S. Constitution.

1126	LEC	9:00 am - 10:25 am	T Th	MEYER, J N	FH 214
1127		- 2:50 hrs	TBA	MEYER, J N	ON LINE
1130	LEC	7:25 am - 8:50 am	T Th	MEYER, J N	FH 218
1131	LEC	7:25 am - 8:50 am	M W	STAFF	FH 218
1132		- 3:10 hrs	TBA	AARON, M	ON LINE
1133	LEC	1:45 pm - 3:10 pm	M W	STAFF	FH 220
1134	LEC	1:45 pm - 3:10 pm	T Th	AARON, M	FH 214
1137	LEC	10:35 am - 12:00 pm	M W	AARON, M	FH 214
1143	LEC	1:45 pm - 3:10 pm	M W	AARON, M	FH 214
3022		- 3:10 hrs	TBA	AARON, M	ON LINE
3036	LEC	6:50 pm -10:00 pm	M	STAFF	FH 223
3318	LEC	6:50 pm -10:00 pm	Th	STAFF	FH 225
3322	LEC	6:50 pm -10:00 pm	T	STAFF	FH 225
3517	LEC	3:30 pm - 6:40 pm	Th	MEYER, J N	FH 218
3518		- 3:10 hrs	TBA	MEYER, J N	ON LINE
3520	LEC	6:50 pm -10:00 pm	W	STAFF	FH 214

SECTION#	TIME	DAYS	INSTRUCTOR	LOCATION
POLITICAL SCIENCE 002 - MODERN WORLD GOVERNMENTS (UC:CSU) - 3.00 UNITS				

ADVISORY: English 28/31 or equivalent. DESCRIPTION: Modern World Governments is a comparative study of the constitutional institutions and political problems of selected governments abroad.

0200	LEC	1:45 pm - 3:10 pm	M W	MEYER, J N	FH 212
1514	LEC	10:35 am - 12:00 pm	T Th	AARON, M	FH 212

SECTION#	TIME	DAYS	INSTRUCTOR	LOCATION
POLITICAL SCIENCE 007 - CONTEMPORARY WORLD AFFAIRS (UC:CSU) - 3.00 UNITS Rpt 1				

ADVISORY: Political Science 1 or equivalent. A study of selected issues in contemporary world affairs from the perspective of the U.S. Class topics include a review of the formulation of American foreign policy; the Vietnam War and its' lessons; the nuclear; and the role of diplomacy and negotiations in resolving various international problems.

0218	LEC	3:30 pm - 6:40 pm	W	AARON, M	FH 225
0219	LEC	9:00 am - 10:25 am	M W	MEYER, J N	FH 218

PSYCHOLOGY

Chair: Rochelle Sechooler, HH100G (323) 953-4000 ext. 2930
<http://www.lacitycollege.edu/academic/departments/psych/index.html>

SECTION#	TIME	DAYS	INSTRUCTOR	LOCATION
PSYCHOLOGY 001 - GENERAL PSYCHOLOGY I (UC:CSU) - 3.00 UNITS				

ADVISORY: English 28 or equivalent. DESCRIPTION: A general introduction to the scientific study of human behavior. An emphasis is placed upon learning, motivation, intelligence, feelings and emotions, personality, and methods of adjustment. *Special tutorial assistance available as they are SI sections.

1148	LEC	7:25 am - 8:50 am	M W	BALDWIN, A B	HH 101
1149	LEC	7:25 am - 8:50 am	T Th	BALDWIN, A B	HH 101
1150	LEC	10:35 am - 12:00 pm	T Th	PAVLIK, A L	HH 104
*1151	LEC	9:00 am - 10:25 am	M W	PAVLIK, A L	HH 107
1152	LEC	10:35 am - 12:00 pm	M W	FAZI, K	HH 105

SECTION#	TIME	DAYS	INSTRUCTOR	LOCATION
1153	LEC	9:00 am - 10:25 am	T Th	PAVLIK, A L HH 102
1154	LEC	9:00 am - 10:25 am	T Th	STAFF HH 105
1155	LEC	10:35 am - 12:00 pm	M W	BALDWIN, A B HH 102
1156	LEC	10:35 am - 12:00 pm	T Th	BLUM, J S HH 101
1157	LEC	12:10 pm - 3:20 pm	M	STAFF HH 104
1158	LEC	9:00 am - 10:25 am	M W	VASQUEZ, E A HH 106
1159	LEC	1:45 pm - 3:10 pm	T Th	BLUM, J S HH 101
1182	LEC	1:00 pm - 4:10 pm	T	STAFF HH 104
3522	LEC	5:15 pm - 6:40 pm	M W	STAFF HH 102
3524	LEC	3:30 pm - 6:40 pm	T	BLOOM, A HH 105
3525	LEC	6:50 pm -10:00 pm	M	RIFKIN, T HH 105
3526	LEC	6:50 pm -10:00 pm	T	SNEED, R HH 105
3527	LEC	6:50 pm -10:00 pm	W	WHEELER, M J HH 105
3528	LEC	6:50 pm -10:00 pm	Th	CRAIG, M M HH 102

PSYCHOLOGY 002 - GENERAL PSYCHOLOGY II (UC:CSU) - 3.00 UNITS

This course explains psychological behavior on the basis of events taking place in the brain, nervous systems and endocrine glands. The biological events which underlie these systems are explained and identified with regard to their effect on moods, sexuality, motivation, sleep, perception, and learning.

1160	LEC	9:00 am - 10:25 am	M W	FAIAZI, K HH 7
1161	LEC	9:00 am - 10:25 am	T Th	BALDWIN, A B HH 101
1189	LEC	10:35 am - 12:00 pm	M W	SECHOOLER, R L HH 101
3529	LEC	6:50 pm -10:00 pm	Th	FAIAZI, K HH 105
3532	LEC	3:30 pm - 6:40 pm	Th	HERRING, F H HH 102

PSYCHOLOGY 003 - PERSONALITY AND SOCIAL DEVELOPMENT (CSU) - 3.00 UNITS

PREREQUISITE: Psychology 1. ADVISORY: English 28/31 or equivalent. DESCRIPTION: Psychology of personal growth. Focuses on self-awareness, self-acceptance, and self-disclosure.

1162	LEC	9:00 am - 10:25 am	M W	BLUM, J S HH 102
3530	LEC	6:50 pm -10:00 pm	M	PAVLIK, A L HH 206

PSYCHOLOGY 013 - SOCIAL PSYCHOLOGY (UC:CSU) - 3.00 UNITS

PREREQUISITE: Psychology 1. DESCRIPTION: The study of social influences on our behavior, attitudes, and feelings.

1163	LEC	12:10 pm - 3:20 pm	M	BLUM, J S HH 101
------	-----	--------------------	---	------------------

PSYCHOLOGY 014 - ABNORMAL PSYCHOLOGY (UC:CSU) - 3.00 UNITS

PREREQUISITE: Psychology 1. DESCRIPTION: An overview of abnormal behavior from the perspective of contemporary medical, psycho-social, and socio-cultural approaches. Abnormal disorders are described, and their major causes and treatment are reviewed.

1165	LEC	10:35 am - 12:00 pm	M W	DANIEL, B P HH 104
3531	LEC	6:50 pm -10:00 pm	Th	DANIEL, B P HH 104

PSYCHOLOGY 027 - ONLINE AND SOFTWARE RESOURCES FOR HUMAN SERVICES - 1.00 UNITS

DESCRIPTION: This course provides Human Services majors with a basic introduction to pertinent computer resources currently being utilized by human services professionals. Hands-on training will allow students to become familiar with software and online resources commonly being used.

1180		- 19:05 hrs	TBA	BALDWIN, A B ON LINE
<i>(4 Week Class - Starts 10/23/2010, Ends 11/13/2010)</i>				
3479	LEC	3:30pm- 5:30pm	Th	BLUM, J S HH 101
<i>(9 Week Class - Starts 10/7/2010, Ends 12/2/2010)</i>				

SECTION#	TIME	DAYS	INSTRUCTOR	LOCATION
PSYCHOLOGY 041 - LIFE-SPAN PSYCHOLOGY: FROM INFANCY TO OLD AGE (UC:CSU) - 3.00 UNITS				
PREREQUISITE: Psychology 1. DESCRIPTION: This course familiarizes the student with physical, cognitive and social growth and change affecting individuals during their many life stages. Periods examined include prenatal, neonatal, infancy, childhood, adolescence, adulthood and old age.				
1166	LEC	9:00 am - 10:30 am	M W	DANIEL, B P HH 104
1186	LEC	12:00 pm - 1:35 pm	T Th	BLOOM, A HH 102
1187	LEC	10:35 am - 12:00 pm	M W	PAVLIK, A L HH 106
3533	LEC	3:30 pm - 6:40 pm	T	BLUM, J S HH 101
3534	LEC	6:50 pm -10:00 pm	W	PAVLIK, A L HH 101

PSYCHOLOGY 043 - PRINCIPLES OF GROUP DYNAMICS I (CSU) - 3.00 UNITS

ADVISORY: English 28 or concurrent enrollment in Learning Skills 1 and/or 7. DESCRIPTION: (Graded on a credit/no-credit basis.) Introduction to the dynamics of group interactions with an emphasis upon the individual's first-hand experience as the group studies itself.

1167	LEC	10:35 am - 12:00 pm	M W	BLUM, J S HH 10
1170	LEC	10:35 am - 12:00 pm	T Th	BALDWIN, A B HH 10
1171	LEC	12:10 pm - 3:20 pm	M	FAIAZI, K HH 10
3535	LEC	4:30 pm - 7:40 pm	T	FAIAZI, K HH 10
3543	LEC	6:50 pm -10:00 pm	W	VARTANIAN, L M HH 10

PSYCHOLOGY 044 - PRINCIPLES OF GROUP DYNAMICS II (CSU) - 3.00 UNITS

PREREQUISITE: Psychology 43. DESCRIPTION: This course covers the role of group processes in changing behavior, as well as the principle modes of counseling and therapy.

1172	LEC	2:20 pm - 5:30 pm	W	FAIAZI, K HH 104
------	-----	-------------------	---	------------------

PSYCHOLOGY 045 - ISSUES IN HUMAN SERVICE CAREERS (CSU) - 3.00 UNITS

PREREQUISITE: Psychology 44, and Psychology 82. DESCRIPTION: The course covers specialized areas of psychology such as crisis intervention, psychopharmacology, counseling ethics, and interviewing. Included are techniques for agency survival such as job interviewing, report writing and resource referral.

3537	LEC	6:50 pm -10:00 pm	M	DANIEL, B P HH 102
-------------	------------	--------------------------	----------	---------------------------

PSYCHOLOGY 052 - PSYCHOLOGICAL ASPECTS OF HUMAN SEXUALITY (UC:CSU) - 3.00 UNITS

DESCRIPTION: This course explores the Psychological aspects of human sexuality. It emphasizes the effect of sexual development and function on self concept and sexual identity. Topics included are: history of sexuality; myths and fallacies; physiology of sexuality; sexually transmitted diseases; paraphilias and sexual orientation.

1173	LEC	9:00 am - 10:25 am	M W	BALDWIN, A B HH 101
------	-----	--------------------	-----	---------------------

PSYCHOLOGY 060 - STRESS MANAGEMENT (CSU) - 3.00 UNITS

DESCRIPTION: This course examines methods of identifying and managing environmental, organizational, social and internal stress in an effort to promote more effective coping on the part of the individual in occupational, interpersonal and everyday life situations.

3037	LEC	6:00 pm - 9:10 pm	M	SECHOOLER, R L HH 7
-------------	------------	--------------------------	----------	----------------------------

PSYCHOLOGY 063 - ALCOHOL/DRUG STUDIES: PREVENTION AND EDUCATION (CSU) - 3.00 UNITS

DESCRIPTION: This course introduces students to prevention and education of alcohol, drug problems and HIV/AIDS among various populations.

3538	LEC	6:50 pm -10:00 pm	Th	JOHANSEN, L M HH 101
-------------	------------	--------------------------	-----------	-----------------------------

SECTION#	TIME	DAYS	INSTRUCTOR	LOCATION
PSYCHOLOGY 064 - INTRODUCTION TO ALCOHOL AND DRUG ABUSE (CSU) - 3.00 UNITS				

DESCRIPTION: This course is an introduction to the: physiology and psychopharmacology of drugs and alcohol, theories of addiction, historical overview of treatment, drug classification, social policy and drug abuse, and the issues of relapse, rehabilitation and recovery.

3539	LEC	6:50 pm -10:00 pm	W	PRINCE, P J	HH 102
------	-----	-------------------	---	-------------	--------

PSYCHOLOGY 065 - CHEMICAL DEPENDENCY:INTERVENTION, TREATMENT AND RECOVERY (CSU) - 3.00 UNITS				
---	--	--	--	--

DESCRIPTION: This course introduces the student to the processes of treatment and recovery of alcohol and drug abuse among various populations. An overview of the causes, treatment, models, and recovery, relapse, rehabilitation, and aftercare is emphasized.

3540	LEC	6:50 pm -10:00 pm	M	TROCKI MILLER, S	HH 104
------	-----	-------------------	---	------------------	--------

PSYCHOLOGY 066 - INTRODUCTION TO CRITICAL THINKING (CSU) - 3.00 UNITS				
--	--	--	--	--

Advisory: English 28 or equivalent. Description: This course will apply the theories and research evidence in cognitive psychology to enhance the ability to effectively solve problems, make decisions, and think creatively. Practice with a variety of problems and simulations will take place to ensure the learning and retention of these critical thinking skills.

1542	LEC	12:30 pm - 3:40 pm	M	SECHOOLER, R L	HH 101
------	-----	--------------------	---	----------------	--------

PSYCHOLOGY 067 - COUNSELING TECHNIQUES FOR THE CHEMICALLY ADDICTED (CSU) - 3.00 UNITS				
--	--	--	--	--

DESCRIPTION: This course will focus on the environment of chemical dependency counseling and the issues of the paraprofessional in alcohol and drug abuse treatment facilities. Case management in a multi-discipline team will be emphasized. All aspects of modern treatment techniques will be covered in class.

3541	LEC	6:50 pm -10:00 pm	T	DANIEL, D E	HH 104
------	-----	-------------------	---	-------------	--------

PSYCHOLOGY 068 - BIOPSYCHOLOGY OF CHEMICAL DEPENDENCY:DRUGS, BEHAVIOR& HEALTH (CSU) - 3.00 UNITS				
---	--	--	--	--

This course offers comprehensive instruction on the pharmacological and behavioral effects of all major categories of both legal and illegal psychoactive substances, including an overview of contemporary and historical drug regulation and abuse, and a detailed review of the nervous system.

3689	LEC	6:50 pm -10:10 pm	W	SOLOF, B S	HH 202
------	-----	-------------------	---	------------	--------

PSYCHOLOGY 081 - FIELD WORK I (CSU) - 3.00 UNITS Rpt 1				
---	--	--	--	--

CO-REQUISITE: Psychology 1 and Psychology 43. DESCRIPTION: This course is designed to orient the student to the field of Human Services. The primary emphasis is on observations of the application of interpersonal relationship skills in community settings. This class is intended for students new to Human Services Field Work. Basic counseling, and communication skills will be taught. This class open to ALL Field Work Students.

5146	LEC	5:30 pm - 6:35 pm	Th	DANIEL, B P	HH 104
AND	LAB	- 5:25 hrs	TBA	DANIEL, B P	FIEL D
5147	LEC	4:30 pm - 5:35 pm	M	SECHOOLER, R L	HH 101
AND	LAB	- 5:25 hrs	TBA	SECHOOLER, R L	FIEL D
8505	LEC	9:00 am -10:05 am	M	SECHOOLER, R L	HH 105
AND	LAB	- 5:20 hrs	TBA	SECHOOLER, R L	FIEL D
8506	LEC	9:00 am -10:05 am	T	DANIEL, B P	HH 104
AND	LAB	- 6:10 hrs	TBA	DANIEL, B P	FIEL D

PSYCHOLOGY 082 - FIELD WORK II (CSU) - 3.00 UNITS Rpt 1				
--	--	--	--	--

PREREQUISITE: Psychology 81. DESCRIPTION: This course is a continuation of Field Work I. There is more student participation, under supervision, at facilities that offer Human Services. This class is intended for more Advanced Students of Human Services Field Work.

5148	LEC	4:30 pm - 5:35 pm	M	SECHOOLER, R L	HH 101
AND	LAB	- 5:25 hrs	TBA	SECHOOLER, R L	FIEL D
5149	LEC	5:30 pm - 6:35 pm	Th	DANIEL, B P	HH 104
AND	LAB	- 5:25 hrs	TBA	DANIEL, B P	FIEL D

SECTION#	TIME	DAYS	INSTRUCTOR	LOCATION	
8507	LEC	10:35 am - 11:40 am	T	SECHOOLER, R L	HH 102
AND	LAB	- 5:20 hrs	TBA	SECHOOLER, R L	FIEL D

PSYCHOLOGY 083 - FIELD WORK III (CSU) - 3.00 UNITS Rpt 1				
---	--	--	--	--

PREREQUISITE: Psychology 82. DESCRIPTION: This course is an advanced course designed to give the student more specialized participation in Human Services, and work in community agencies. This class is intended for Advanced Students of Human Services.

5150	LEC	5:30 pm - 6:35 pm	Th	DANIEL, B P	HH 104
AND	LAB	- 5:25 hrs	TBA	DANIEL, B P	FIEL D
5151	LEC	5:30 pm - 6:35 pm	Th	DANIEL, B P	HH 104
AND	LAB	- 5:25 hrs	TBA	DANIEL, B P	FIEL D
8509	LEC	10:35 am - 11:40 am	T	SECHOOLER, R L	HH 102
AND	LAB	- 5:20 hrs	TBA	SECHOOLER, R L	FIEL D

PSYCHOLOGY 084 - FIELDWORK I, DRUG/ALCOHOL (CSU) - 3.00 UNITS				
--	--	--	--	--

CO-REQUISITE: Psychology 1 and Psychology 43. DESCRIPTION: Lecture 1 hour; Field Work, 6 hours per week. This laboratory class is designed to give the student community experience in the field of drug/alcohol counseling, treatment, prevention and/or education.

5152	LEC	5:30 pm - 6:35 pm	Th	DANIEL, B P	HH 104
AND	LAB	- 5:25 hrs	TBA	DANIEL, B P	FIEL D
5153	LEC	4:30 pm - 5:35 pm	M	SECHOOLER, R L	HH 101
AND	LAB	- 5:25 hrs	TBA	SECHOOLER, R L	FIEL D
8512	LEC	9:00 am - 10:05 am	T	DANIEL, B P	HH 104
AND	LAB	- 6:10 hrs	TBA	DANIEL, B P	FIEL D

PSYCHOLOGY 085 - FIELDWORK II, DRUG/ALCOHOL (CSU) - 3.00 UNITS				
---	--	--	--	--

PREREQUISITE: Psychology 84. DESCRIPTION: Lecture 1 hour; Field Work, 6 hours per week. This class is designed to orient the student to the field of Human Services, Drug/Alcohol Studies. The primary emphasis is on the observations of the application of interpersonal relationship skills in drug/alcohol treatment and community settings. This class is intended for students new to Human Services field work. Basic counseling and communication skills will be taught.

5154	LEC	4:30 pm - 5:35 pm	M	SECHOOLER, R L	HH 101
AND	LAB	- 5:25 hrs	TBA	SECHOOLER, R L	FIEL D
5155	LEC	5:30 pm - 6:35 pm	Th	DANIEL, B P	HH 104
AND	LAB	- 5:25 hrs	TBA	DANIEL, B P	FIEL D
8513	LEC	10:35 am - 11:40 am	T	SECHOOLER, R L	HH 102
AND	LAB	- 5:20 hrs	TBA	SECHOOLER, R L	FIEL D

PSYCHOLOGY 086 - FIELDWORK III, DRUG/ALCOHOL (CSU) - 3.00 UNITS				
--	--	--	--	--

PREREQUISITE: Psychology 85. DESCRIPTION: Lecture, 1 hour, Field Work, 6 hours per week. This course is designed to orient the student to the field of Human Services, Drug/Alcohol Studies. The primary emphasis is on the observations of the application of interpersonal relationship skills in drug/alcohol treatment and community settings. This class is intended for students new to Human Services field work. Basic counseling and communication skills will be taught.

5156	LEC	4:30 pm - 5:35 pm	M	SECHOOLER, R L	HH 101
AND	LAB	- 5:25 hrs	TBA	SECHOOLER, R L	FIEL D
5157	LEC	5:30 pm - 6:35 pm	Th	DANIEL, B P	HH 104
AND	LAB	- 5:25 hrs	TBA	DANIEL, B P	FIEL D
8515	LEC	10:35 am - 11:40 am	T	SECHOOLER, R L	HH 102
AND	LAB	- 5:20 hrs	TBA	SECHOOLER, R L	FIEL D

PSYCHOLOGY 185 - DIRECTED STUDY - PSYCHOLOGY (CSU) - 1.00 UNITS Rpt 2				
--	--	--	--	--

PREREQUISITE: Psychology 1 plus one additional course in Psychology and signature of instructor.

8517	LEC	- 1:05 hrs	TBA	BLUM, J S	HH 100
------	-----	------------	-----	-----------	--------

SECTION#	TIME	DAYS	INSTRUCTOR	LOCATION
PSYCHOLOGY 285 - DIRECTED STUDY - PSYCHOLOGY (CSU) - 2.00 UNITS				

PREREQUISITE: Psychology 1 plus one additional course in Psychology and signature of instructor.

8518	LEC	- 2:10 hrs	TBA	BLUM, J S	HH 100
------	-----	------------	-----	-----------	--------

PSYCHOLOGY 385 - DIRECTED STUDY - PSYCHOLOGY (CSU) - 3.00 UNITS				
--	--	--	--	--

PREREQUISITE: Psychology 1 plus one additional course in Psychology and signature of instructor.

8519	LEC	- 3:20 hrs	TBA	BLUM, J S	HH 100
------	-----	------------	-----	-----------	--------

PSYCHOLOGY 931 - COOPERATIVE EDUCATION - PSYCHOLOGY (CSU) - 3.00 UNITS Rpt 3				
---	--	--	--	--

9130		- 3:30 hrs	TBA	WERBLE, D M	AD 209
------	--	------------	-----	-------------	--------

PSYCHOLOGY 941 - COOPERATIVE EDUCATION - PSYCHOLOGY (CSU) - 4.00 UNITS Rpt 3				
---	--	--	--	--

9131		- 5:05 hrs	TBA	WERBLE, D M	AD 209
------	--	------------	-----	-------------	--------

RADIOLOGIC TECHNOLOGY

Chair: John Radtke, RT3A (323) 953-4000 ext. 2942

<http://www.lacitycollege.edu/academic/departments/radtech/index.html>

RADIOLOGIC TECHNOLOGY 100 - INTRODUCTION TO RADIOLOGIC TECHNOLOGY - 1.00 UNITS				
---	--	--	--	--

DESCRIPTION: (Open to all students.) An introduction course for students interested in a career in Radiologic Technology. The role of the Radiographer and career advancement are emphasized. Students interested in taking advanced classes in Radiologic Technology must successfully complete RT 100 and RT 101. Clinical education centers will be visited.

1192	LEC	10:00 am - 11:05 am	T	FINNEY, J F	FH 117
3557	LEC	7:00 pm - 7:55 pm	Th	ALFARO, A O	FH 117

RADIOLOGIC TECHNOLOGY 101 - MEDICAL TERMINOLOGY FOR RADIOLOGIC TECHNOLOGY - 1.00 UNITS				
---	--	--	--	--

ADVISORY: English 28 & 67. DESCRIPTION: (Open to all students.) This course is designed to familiarize the student with medical terminology used in the field of Radiologic Technology. Students interested in taking advanced classes in Radiologic Technology must successfully complete RT 100 and RT 101.

1193	LEC	8:00 am - 9:05 am	T	FINNEY, J F	FH 117
3558	LEC	5:45 pm - 6:50 pm	Th	ALFARO, A O	FH 117

RADIOLOGIC TECHNOLOGY 102 - IMAGE RECORDING AND FILM PROCESSING - 3.00 UNITS				
---	--	--	--	--

PREREQUISITE: Completion of English 28 or equivalent; Radiologic Technology 100 and 101. Advisories: Math 115 and English67. Students gain the knowledge to understand x-ray production, image recording, and film processing. Students are also introduced to radiation protection. Laboratory experience is included.

1194	LEC	12:00 pm - 1:05 pm	T Th	FINNEY, J F	RT 1
AND	LAB	1:05 pm - 2:05 pm	T Th	FINNEY, J F	RT 1
3559	LEC	5:00 pm - 7:00 pm	T	ALFARO, A O	RT 1
AND	LAB	7:05 pm - 9:05 pm	T	ALFARO, A O	RT 1

RADIOLOGIC TECHNOLOGY 103 - RADIOGRAPHIC ANATOMY AND POSITIONING SKELETAL SYSTEM - 4.00 UNITS				
--	--	--	--	--

PREREQUISITE: Radiologic Technology 102 and Admission to the Radiologic Technology Program. Students learn radiographic anatomy, positioning and selected pathology of the musculoskeletal system. Laboratory experience is included.

1191	LEC	12:00 pm - 1:25 pm	T Th	RADTKE, J G	RT 10
AND	LAB	1:25 pm - 2:50 pm	T Th	RADTKE, J G	RT 10
1195	LEC	12:00 pm - 1:25 pm	M W	FINNEY, J F	RT 10
AND	LAB	1:25 pm - 2:50 pm	M W	FINNEY, J F	RT 10

SECTION#	TIME	DAYS	INSTRUCTOR	LOCATION
RADIOLOGIC TECHNOLOGY 105 - FUNDAMENTALS OF X-RAY PHYSICS - 3.00 UNITS				

PREREQUISITE: Radiologic Technology 100, 101, and 102. Admission to the Radiologic Technology Program. DESCRIPTION: Students learn the basic physical principles of x-ray generation. Emphasis is placed on the electrical circuitry of radiographic equipment. Interactions between X-ray radiation and matter is explained and students learn the principles that govern radiographic technique and quality.

1196	LEC	7:50 am - 11:00 am	F	RADTKE, J G	RT 5
------	-----	--------------------	---	-------------	------

RADIOLOGIC TECHNOLOGY 107 - PATIENT CARE AND MANAGEMENT - 3.00 UNITS				
---	--	--	--	--

PREREQUISITE: Radiologic Technology 102. Admission to the Radiologic Technology Program. DESCRIPTION: Students learn the principles of patient care management for radiographers. Routine and emergency care procedures are discussed. The role of the radiographer in patient education will also be explained. Laboratory experience is included.

1197	LEC	8:00 am - 10:00 am	M W	FINNEY, J F	RT 5
AND	LAB	10:00 am - 10:30 am	M W	FINNEY, J F	RT 5
3561	LEC	4:00 pm - 6:05 pm	M W	FINNEY, J F	RT 5
AND	LAB	6:05 pm - 6:35 pm	M W	FINNEY, J F	RT 5

RADIOLOGIC TECHNOLOGY 110 - RADIOGRAPHIC MATHEMATICS - 2.00 UNITS				
--	--	--	--	--

PREREQUISITE: Radiologic Technology 102. Admission to the Radiologic Technology Program. DESCRIPTION: Students learn the principles of mathematics encountered in Radiologic Technology. This course complements Radiologic Technology 105 and Radiologic Technology 106.

1198	LEC	12:00 pm - 2:05 pm	F	RADTKE, J G	RT 5
------	-----	--------------------	---	-------------	------

RADIOLOGIC TECHNOLOGY 180 - CLINICAL EDUCATION IN RADIOLOGIC TECHNOLOGY - 12.00 UNITS Rpt 2				
--	--	--	--	--

PREREQUISITE: Radiologic Technology 103, 104, 105, 106, 107, 110, 140 and 160 . DESCRIPTION: Students perform all duties of a radiographer under the direction of a clinical education instructor. Students are dismissed from the clinical site to return to the campus to attend regular classes in late afternoons and evenings. Students are evaluated on a credit/no credit basis.

5162	LAB	- 3:10 hrs	TBA	RADTKE, J G	RT 5
AND	LAB	- 19:05 hrs	TBA	RADTKE, J G	FIEL D
AND	LAB	- 23:10 hrs	TBA	RADTKE, J G	FIEL D

REAL ESTATE

Chair: Thelma Day, AD304 (323) 953-4000 ext. 2541

<http://www.lacitycollege.edu/academic/departments/busad/index.html>

REAL ESTATE 001 - REAL ESTATE PRINCIPLES (CSU) - 3.00 UNITS				
--	--	--	--	--

Open to all students. ADVISORY: English 28. DESCRIPTION: This course is required for the California Real Estate examination. A beginning course in real estate fundamentals and principles, including real estate economics, terminology and definitions, real estate law, building and construction, real estate investment, and vocational opportunities in real estate.

3007	LEC	- 3:10 hrs	TBA	ANDERSON, R L	ON LINE
				andersrl@lacitycollege.edu	
3566	LEC	3:30 pm - 6:40 pm	W	DUFFY, T E	HH 203
3676	LEC	6:50 pm - 10:00 pm	Th	ANDERSON, R L	AD 306

REAL ESTATE 003 - REAL ESTATE PRACTICES (CSU) - 3.00 UNITS				
---	--	--	--	--

Open to all students. ADVISORY: English 28 or equivalent. DESCRIPTION: A practice study of the principles, economic aspects, and laws of real estate, including the information encumbrances, agencies, contracts, financing, appraisals, escrow and title, leases, urban economics, taxation, and vocational careers.

0349	LEC	9:00 Am - 12:10 pm	S	ANDERSON, R L	AD 306
3536	LEC	6:50 pm - 10:00 pm	M	EISENBERG, M R	HH 205

SECTION#	TIME	DAYS	INSTRUCTOR	LOCATION
----------	------	------	------------	----------

REAL ESTATE 005 - LEGAL ASPECTS OF REAL ESTATE I (CSU) - 3.00 UNITS

Open to all students. ADVISORY: English 28. DESCRIPTION: Legal background for those who plan to take the state examination which is required in order to obtain a license to be a real estate salesperson or broker, including principles of property ownership and management in their business aspects, with special reference to the law of California as it applies to community property, deeds, trust deeds, mortgages, leases, brokerage, mechanic's liens, homesteads, wills, and estates.

3569 LEC 6:50 pm -10:00 pm T LANZER, K C HH 206

REAL ESTATE 007 - REAL ESTATE FINANCE I (CSU) - 3.00 UNITS

Open to all students. ADVISORY: English 28 or equivalent. DESCRIPTION: A study of the forms and sources of financing real property, including purchase, construction, refinance, and other creative permanent financing. Also included is an assessment of the procedures for obtaining government sponsored financing through FHA, DVA, and Cal-Vet. The various loan services being used in the market place will be evaluated including banks, savings and loans, insurance companies, mortgage brokers/bankers, pensions, credit unions, and private parties.

3581 LEC 6:50 pm -10:00 pm W ANDERSON, R L AD 306

REAL ESTATE 009 - REAL ESTATE APPRAISAL I (CSU) - 3.00 UNITS

ADVISORY: English 28 or equivalent.

3572 LEC 6:50 pm -10:00 pm T PARSAKAR, N HH 202

REAL ESTATE 014 - PROPERTY MANAGEMENT (CSU) - 3.00 UNITS

Advisory: English 28 or equivalent.

3212 LEC 6:50 pm -10:00 pm M ENGLUND, A C HH 204

REAL ESTATE 021 - REAL ESTATE ECONOMICS (CSU) - 3.00 UNITS

ADVISORY: Eligibility to enroll in English 28.

1674 LEC 12:15 pm - 3:25 pm S SHORT, L J AD 301B

REAL ESTATE 060 - REAL ESTATE MATHEMATICS (CSU) - 3.00 UNITS

Prerequisite: English 28/31 or equivalent. This course consists of typical real estate mathematics problems which are most common in actual practice, as well as those necessary for other real estate courses and for those found in the California Real Estate Licensing examinations.

1202 LEC - 3:10 hrs TBA ANDERSON, R L ON LINE
andersrl@lacitycollege.edu

REGISTERED, NURSING

Chair: Betsy Manchester, SCI 222C (323) 953-4000 ext. 2065

<http://www.lacitycollege.edu/academic/departments/nursing/index.html>

REGISTERED, NURSING 103 - NURSING PHARMACOLOGY (CSU) - 1.00 UNITS

CO-REQUISITE: Registered Nursing 104. First semester nursing students acquire introductory knowledge about the most frequently prescribed medications, their side effects, and possible interactions that are used in health care settings today.

6100 LEC 8:00 am - 9:00 am M SIMPSON TURK, J Y SCI 208

REGISTERED, NURSING 104 - NURSING FOUNDATIONS (CSU) - 4.00 UNITS

PREREQUISITE: Math 115, English 101, Sociology 1, Psychology 1, Psychology 41, Physiology 1, Microbiology 20 and Anatomy 1. Students acquire introductory knowledge about theoretical concepts and fundamental skills in nursing that are required for safe patient care. Students also learn and apply the Roy Adaptation Model nursing process as the conceptual framework for practice. Then students develop enhanced critical thinking and psychomotor skills during the clinical component.

6101 LEC 9:30 am - 12:00 pm M STAFF SCI 107
AND LEC 9:30 am - 12:00 pm Th UPSHAW, D K SCI 107

SECTION#	TIME	DAYS	INSTRUCTOR	LOCATION
----------	------	------	------------	----------

OR LAB	7:00 am - 1:30 pm	TW	AUSTIN, N	FIELD D
OR LAB	7:00 am - 1:30 pm	TW	STAFF	FIELD D
OR LAB	7:00 am - 1:30 pm	TW	UPSHAW, D K	FIELD D

(8 Week Class - Starts 8/30/2010, Ends 10/22/2010)

REGISTERED, NURSING 105 - BEGINNING MEDICAL- SURGICAL (CSU) - 5.00 UNITS

PREREQUISITE: Registered Nursing 104. Students acquire enhanced knowledge about the Roy Adaptation Model nursing process and implement this as the framework for nursing care. Students also develop introductory knowledge and understanding of common medical-surgical health problems. Additionally, students apply theoretical concepts and nursing skills in a clinical setting.

6105 LEC	9:30 am - 12:40 pm	M	STAFF	SCI 107
AND LEC	9:00 am - 12:10 pm	Th	UPSHAW, D K	SCI 107
OR LAB	7:00 am - 3:30 pm	TW	AUSTIN, N	FIELD D
OR LAB	7:00 am - 3:30 pm	TW	UPSHAW, D K	FIELD D
OR LAB	7:00 am - 3:30 pm	TW	STAFF	FIELD D

(8 Week Class - Starts 10/25/2010, Ends 12/19/2010)

REGISTERED, NURSING 106 - NURSING CARE OF THE CHILDBEARING FAMILY (CSU) - 4.00 UNITS

PREREQUISITE: RN 105 with a satisfactory grade or better. Utilizing the Roy Adaptation model and the nursing process, the students in Nursing Care of the Childbearing Family focus on nursing care of culturally diverse families experiencing reproductive health, child bearing, and breast and reproductive cancers. The students apply concepts that include disease processes, medical treatments, nursing responsibilities, and interventions, cultural, ethical, and legal issues to the childbearing family.

0995 LEC	10:40 am - 12:45 pm	W	BERRY, L	SCI 107
AND LAB	7:00 am - 7:00 pm	M	LAX, L M	FIELD D
OR LAB	7:00 am - 7:00 pm	M	BURTON, J L	FIELD D
OR LAB	7:00 am - 7:00 pm	Th	BERRY, L	FIELD D

REGISTERED, NURSING 107 - NURSING CARE OF THE PEDIATRIC CLIENT (CSU) - 4.00 UNITS

PREREQUISITE: RN 105 with a satisfactory grade or better. Utilizing the Roy Adaptation Model and the nursing process, students in pediatric nursing focus on the nursing care of children of various ages and their families. The student applies concepts that include disease process, medical treatments, nursing responsibilities, interventions, cultural, ethical, and legal issues to the pediatric population.

0996 LEC	8:00 am - 10:05 am	W	SIMPSON TURK, J Y	SCI 107
AND LAB	6:30 am - 2:40 pm	ThF	SIMPSON TURK, J Y	FIELD D
OR LAB	6:30 am - 2:40 pm	ThF	YEH, R B	FIELD D
OR LAB	6:30 am - 2:40 pm	ThF	SIMPSON TURK, J Y	FIELD D
OR LAB	6:30 am - 2:40 pm	ThF	YEH, R B	FIELD D

REGISTERED, NURSING 108 - NURSING CARE FOR THE CLIENT WITH PSYCHOSOCIAL NEEDS (CSU) - 4.00 UNITS Rpt 1

PREREQUISITE: Completion of RN 107 with a satisfactory grade or better. DESCRIPTION: This course is designed to provide correlated theoretical knowledge and clinical experience in the care of the psychiatric patient in the acute care facility. Emphasis will be on the holistic care of clients with mental health problems, cognitive disorders, and/or difficulties in coping with problems of daily living.

6106 LEC	8:00 am - 10:05 am	Th	LEVY, D A	CD 215
OR LAB	7:00 am - 7:00 pm	M F	LEVY, D A	FIELD D
OR LAB	7:00 am - 7:00 pm	SU	MENDEZ, G	FIELD D
OR LAB	7:00 am - 7:00 pm	M F	STAFF	FIELD D

REGISTERED, NURSING 109 - INTERMEDIATE MEDICAL-SURGICAL NURSING (CSU) - 5.00 UNITS

PREREQUISITE: Completion of RN 106 and RN 107 with a satisfactory grade or better and approved second year status in RN program. DESCRIPTION: This course provides knowledge and clinical experience in the care of the hospitalized, acutely ill adult and older adult patient whose health care needs require increasingly complex nursing interventions and skills. This course also incorporates a gerontology component with

SECTION#	TIME	DAYS	INSTRUCTOR	LOCATION
clinical practicum. The Roy Adaptation model will be used in conjunction with the nursing process to implement and evaluate care for assigned patients.				
6107	LEC 10:30 am - 1:20 pm	Th	PORTUGAL, A	CD 215
OR	LAB 7:00 am - 7:00 pm	M T	PORTUGAL, A	FIEL D
OR	LAB 7:00 am - 4:30 pm	TW	CASTILLO, R	FIEL D

REGISTERED, NURSING 110 - ADVANCE MEDICAL-SURGICAL NURSING (CSU) - 5.00 UNITS

Prerequisite: Registered Nursing 108 and 109. In this advanced nursing course, students understand and apply advanced theoretical and clinical concepts in the care of medical-surgical patients with complex problems. Student acquires translational knowledge about complex concepts that include ECG monitoring, beginning ventilatory management, hemodynamic monitoring, care of the client with multisystem failure, and nursing care in emergency situations. Students will apply theoretical knowledge across all specialty care settings.

0999	LEC 9:00 am - 1:40 pm	M	FARRAND, F M	CD 214
AND	LAB 7:00 am - 3:00 pm	TW	FARRAND, F M	FIEL D
OR	LAB 7:00 am - 3:00 pm	TW	FEKETE, M M	FIEL D
OR	LAB 7:00 am - 3:00 pm	ThF	PABELLANO, M A	FIEL D

(8 Week Class - Starts 8/30/2010, Ends 10/24/2010)

REGISTERED, NURSING 111 - NURSING LEADERSHIP AND MANAGEMENT (CSU) - 4.00 UNITS

Prerequisite: Registered Nursing 110. Students explore, and apply the legal, ethical and current issues and trends that affect the Registered Nurse today within the context of the Roles of Practice. Students will complete a 108 clinical preceptorship in an acute care setting.

1000	LEC 9:00 am - 1:15 pm	M	FARRAND, F M	CD 214
AND	LAB 7:00 am - 2:30 pm	TW	FARRAND, F M	FIEL D
OR	LAB 7:00 am - 2:30 pm	TW	FEKETE, M M	FIEL D
OR	LAB 7:00 am - 2:30 pm	ThF	STAFF	FIEL D

(7 Week Class - Starts 10/25/2010, Ends 12/19/2010)

REGISTERED, NURSING 115 - NURSING SKILLS COMPETENCY I (CSU) - 1.00 UNITS

Corequisite: RN 104. Students practice procedures and skills learned in concurrent Fundamentals and Beginning Medical-Surgical Nursing theory and clinical courses.

6110	LAB 1:30 pm - 2:55 pm	M	STAFF	TBA
OR	LAB 1:30 pm - 4:40 pm	Th	UPSHAW, D K	TBA

REGISTERED, NURSING 116 - NURSING SKILLS COMPETENCY II (CSU) - 1.00 UNITS

PREREQUISITE: RN 105 with a satisfactory grade or better. The student participates in this weekly 3 hour adjunct, laboratory course to practice procedures and skills learned in concurrent Fundamentals and Beginning Medical-Surgical Nursing theory and clinical courses.

0997	LAB 1:30 pm - 4:40 pm	W	BERRY, L	TBA
0998	LAB 1:30 pm - 4:40 pm	W	SIMPSON TURK, J Y	TBA

REGISTERED, NURSING 117 - NURSING SKILLS COMPETENCY III (CSU) - 1.00 UNITS Rpt 1

PREREQUISITE: RN107 with a satisfactory grade or better and approved second year status in RN program. DESCRIPTION: This is a self-paced laboratory course for nursing students that will provide weekly open entry skills-based laboratory opportunities to practice and enhance learned nursing skills.

6112	LAB 1:30 pm - 4:40 pm	Th	PORTUGAL, A	TBA TBA
6113	LAB 1:30 pm - 4:40 pm	Th	LEVY, D A	TBA

REGISTERED, NURSING 150 - EXPANDED PRACTICE AND PRINCIPLES OF PEDIATRIC NURSING I (CSU) - 9.00 UNITS Rpt 1

PREREQUISITE: Satisfactory completion with a "C" grade or better of RN11 Nursing. DESCRIPTION: This course emphasizes the competency assessment and is designed to take the graduate nurse from novice to becoming a trained Registered Nurse with a specialty in Pediatrics.

6120	LEC 8:00 am - 3:00 pm	T Th	SIMPSON TURK, J Y	OFF CAMP
------	-----------------------	------	-------------------	----------

SECTION#	TIME	DAYS	INSTRUCTOR	LOCATION
AND	LAB 8:00 am - 3:00 pm	M W F	STAFF	OFF CAMP
(8 Week Class - Starts 8/30/2010, Ends 10/22/2010)				
6130	LEC 8:00 am - 3:00 pm	T Th	SIMPSON TURK, J Y	OFF CAMP
AND	LAB 8:00 am - 3:00 pm	M W F	STAFF	OFF CAMP
(8 Week Class - Starts 8/30/2010, Ends 10/22/2010)				
6140	LEC 8:00 am - 2:30 pm	T Th	SIMPSON TURK, J Y	OFF CAMP
AND	LAB 8:00 am - 3:00 pm	M W F	SIMPSON TURK, J Y	OFF CAMP
(8 Week Class - Starts 8/30/2010, Ends 10/22/2010)				
6160	LAB 8:00 am - 3:05 pm	T Th	SIMPSON TURK, J Y	OFF CAMP
AND	LAB 8:00 am - 3:00 pm	M W F	SIMPSON TURK, J Y	OFF CAMP
(8 Week Class - Starts 8/30/2010, Ends 10/22/2010)				

REGISTERED, NURSING 151 - ROLE DEVELOPMENT IN PEDIATRIC NURSING (CSU) - 8.00 UNITS Rpt 1

PREREQUISITE: Nursing 150 with a "C" grade or better. DESCRIPTION: This course emphasizes role development. Under preceptor guidance the nurse moves from novice toward increased clinical competency in the Pediatric Nurse Residency Program.

6121	LEC 8:00 am - 2:30 pm	T	SIMPSON TURK, J Y	OFF CAMP
AND	LAB 7:00 am - 4:05 pm	M WThF	SIMPSON TURK, J Y	OFF CAMP
(8 Week Class - Starts 10/25/2010, Ends 12/19/2010)				
6131	LAB 8:00 am - 3:00 pm	T	SIMPSON TURK, J Y	OFF CAMP
AND	LAB 7:00 am - 4:05 pm	M WThF	SIMPSON TURK, J Y	OFF CAMP
(8 Week Class - Starts 10/25/2010, Ends 12/19/2010)				
6141	LEC 8:00 am - 2:30 pm	T	SIMPSON TURK, J Y	OFF CAMP
AND	LAB 7:00 am - 6:25 pm	M WTh	SIMPSON TURK, J Y	OFF CAMP
(8 Week Class - Starts 10/25/2010, Ends 12/19/2010)				
6161	LEC 8:00 am - 3:00 pm	T	SIMPSON TURK, J Y	OFF CAMP
AND	LAB 7:00 am - 4:05 pm	M WThF	SIMPSON TURK, J Y	OFF CAMP
(8 Week Class - Starts 10/25/2010, Ends 12/19/2010)				

RUSSIAN

Chair: Eiko K. Chatel, DH312B (323) 953-4000 ext. 2737
<http://www.lacitycollege.edu/academic/departments/forlang/index.html>

RUSSIAN 001 - ELEMENTARY RUSSIAN I (UC:CSU) - 5.00 UNITS

ADVISORY: English 28 and 67 or equivalent. DESCRIPTION: The fundamentals of pronunciation and grammar, practical vocabulary, useful phrases; basic facts on the geography, customs and culture of Russia.

1211	LEC 10:35 am - 11:45 am	MTWTh	IVANOVA, O M	BUNG 11
AND	LAB - 1:05 hrs	TBA	STAFF	DH 319

RUSSIAN 002 - ELEMENTARY RUSSIAN II (UC:CSU) - 5.00 UNITS

PREREQUISITE: Russian 1 or equivalent. DESCRIPTION: Completes Elementary Russian. Emphasis on reading and spoken language.

1212	LEC 12:10 pm - 1:20 pm	MTWTh	IVANOVA, O M	DH 304
3580	LEC 6:50 pm - 9:20 pm	M W	STROM, M A	BUNG 12
AND	LAB -0:55 hrs	TBA	STAFF	DH 319

RUSSIAN 003 - INTERMEDIATE RUSSIAN I (UC:CSU) - 5.00 UNITS

PREREQUISITE: Russian 2 or equivalent. DESCRIPTION: This course continues the study of grammar and vocabulary to advance students' conversation and writing skills. Reading of selected texts in Russian is included.

3555	LEC 3:30 pm - 6:20 pm	M W	GUTKIN, I	DH 310
------	-----------------------	-----	-----------	--------

RUSSIAN 008 - CONVERSATIONAL RUSSIAN (UC:CSU) - 2.00 UNITS Rpt 3

PREREQUISITE: Russian 2 with a satisfactory grade or equivalent. DESCRIPTION: Practical conversation in Russian on everyday topics, and current events, dialogues and group discussion of news in politics, sports, and culture.

3042	LEC 6:50 pm - 8:55 pm	M	GUTKIN, I	DH 305
-------------	------------------------------	----------	------------------	---------------

SECTION# TIME DAYS INSTRUCTOR LOCATION

SOCIOLOGY
 Chair: Wendel Eckford, FH219E (323) 953-4000 ext. 2561
<http://www.lacitycollege.edu/academic/departments/socsci/index.html>

SOCIOLOGY 001 - INTRODUCTION TO SOCIOLOGY (UC:CSU) - 3.00 UNITS

ADVISORY: Eligible for English 28 or equivalent. DESCRIPTION: An introductory course acquaints students with the major principles of sociology as they are applied to contemporary social problems.

1214	LEC	9:00 am - 10:25 am	T Th	CLARK, A	FH 216
1216	LEC	10:35 am - 12:00 pm	T Th	CLARK, A	FH 216
1218	LEC	9:00 am - 10:25 am	M W	RODRIGUEZ, F J	FH 222
1219	LEC	9:00 am - 10:25 am	T Th	RODRIGUEZ, F J	FH 222
1220	LEC	10:35 am - 12:00 pm	M W	RODRIGUEZ, F J	FH 222
1222	-	3:10 hrs	TBACLARK, A	ON LINE	
1235	LEC	1:45 pm - 3:10 pm	M W	CLARK, A	FH 216
3021	LEC	1:00 pm - 4:10 pm	S	STAFF	FH 222
3514	LEC	6:50 pm -10:00 pm	W	CLARK, A	FH 222
3575	LEC	3:30 pm - 6:40 pm	M	RODRIGUEZ, F J	FH 222
3576	LEC	6:50 pm -10:00 pm	T	STAFF	FH 222
3577	LEC	6:50 pm -10:00 pm	W	RODRIGUEZ, F J	FH 222

SOCIOLOGY 002 - AMERICAN SOCIAL PROBLEMS (UC:CSU) - 3.00 UNITS

ADVISORIES: English 28 and 67. Students apply sociological perspectives and concepts in analyzing contemporary social problems in the United States. Problems associated with drug abuse, poverty, racial, ethnic, and gender inequality, crime and violence, and the environment are some of the topics addressed.

1221	LEC	10:35 am - 12:00 pm	T Th	RODRIGUEZ, F J	FH 222
------	-----	---------------------	------	----------------	--------

SPANISH
 Chair: Eiko K. Chatel, DH312B (323) 953-4000 ext. 2737
<http://www.lacitycollege.edu/academic/departments/forlang/index.html>

SPANISH 001 - ELEMENTARY SPANISH I (UC:CSU) - 5.00 UNITS

ADVISORY: English 28 or equivalent. DESCRIPTION: Credit allowed for only one of Spanish 1 OR Spanish 21 and 22 together. Class meets 6 hours; 5 hours lecture and 1 hour TBA in the Language Lab, DH 319. Pronunciation and grammar, practical vocabulary, useful phrases; basic facts on the geography, customs and culture of the Spanish-speaking world. UC accepts one of Spanish 1 or equivalent. NOTE: Spanish 35 is strongly recommended for Spanish speakers. *Special tutorial assistance available in section 1228.

1225	LEC	1:45 pm - 3:00 pm	MTWTh	MORIN, J O	DH 307
AND	LAB	- 1:05 hrs	TBA	STAFF	DH 319
1228*	LEC	9:00 am - 10:10 am	MTWTh	PARADA, Y	DH 309
AND	LAB	- 1:05 hrs	TBA	STAFF	DH 319

Special tutorial assistance available to students in section 1228.

1229	LEC	10:35 am - 11:45 am	MTWTh	PARADA, Y	DH 309
AND	LAB	- 1:05 hrs	TBA	STAFF	DH 319
1233	LEC	10:35 am - 11:45 am	MTWTh	MCQUEEN, O	DH 307
AND	LAB	- 1:05 hrs	TBA	STAFF	DH 319
3332	LEC	5:15 pm - 6:30 pm	MTWTh	MORIN, J O	DH 307
AND	LAB	- 1:05 hrs	TBA	STAFF	DH 319
3584	LEC	6:50 pm - 9:20 pm	M W	CASTEL DE ORO, S	DH 304
AND	LAB	- 1:05 hrs	TBA	STAFF	DH 319
3585	LEC	6:50 pm - 9:20 pm	T Th	CASTILLO, R	DH 310
AND	LAB	- 1:05 hrs	TBA	STAFF	DH 310

SPANISH 002 - ELEMENTARY SPANISH II (UC:CSU) - 5.00 UNITS

PREREQUISITE: Spanish 1 or equivalent. ADVISORY: English 28 and 67. DESCRIPTION: Class meets 6 hours; 5 hours lecture and 1 hour TBA in the Language Lab, DH 319. NOTE: Spanish 36 is strongly recommended for Spanish speakers.

1234	LEC	7:25 am - 8:35 am	MTWTh	RIVERA, M A	DH 308
AND	LAB	- 1:05 hrs	TBA	STAFF	DH 319
1435	LEC	1:45 pm - 2:55 pm	MTWTh	PARADA, Y	DH 310

SECTION# TIME DAYS INSTRUCTOR LOCATION

AND	LAB	- 0:55 hrs	TBA	STAFF	DH 319
3587	LEC	6:50 pm - 9:20 pm	T Th	ZAMORA, S R	DH 304
AND	LAB	- 1:05 hrs	TBA	STAFF	DH 319

SPANISH 003 - INTERMEDIATE SPANISH I (UC:CSU) - 5.00 UNITS

PREREQUISITE: Spanish 2 or equivalent. Review of grammar, composition and vocabulary building. Introduction to Spanish and Latin-American authors.

3336	LEC	3:30 pm - 4:45 pm	MTWTh	MORIN, J O	DH 307
3586	LEC	6:50 pm - 9:20 pm	T Th	ZARATE, S	DH 309

SPANISH 004 - INTERMEDIATE SPANISH II (UC:CSU) - 5.00 UNITS

PREREQUISITE: Spanish 3 or equivalent.

1237	LEC	10:35 am - 11:45 am	MTWTh	BAE, Y	DH 305
------	-----	---------------------	-------	--------	--------

SPANISH 005 - ADVANCED SPANISH I (UC:CSU) - 5.00 UNITS

PREREQUISITE: Spanish 4 or equivalent.

An overall examination of the arts and the concept of aesthetics in preparation for the study of literature. The focus is on the narrative (short story and novel) and poetry in Spanish and Latin American literacy traditions. The course also examines the translation to film of some of the works studied. Discussion generated by lectures and readings provide oral practice in the target language. Written expression and review of grammatical structures, orthography and punctuation is done through essays on selected themes.

0207	LEC	9:00 am - 10:10 am	MTWTh	RIVERA, M A	DH 307
------	-----	--------------------	-------	-------------	--------

SPANISH 008 - CONVERSATIONAL SPANISH (UC:CSU) - 2.00 UNITS Rpt 3

PREREQUISITE: Spanish 2 or equivalent. Course may be taken 4 times.

1238	LEC	12:10 pm - 2:10 pm	T	RIVERA, M A	DH 308
------	-----	--------------------	---	-------------	--------

SPANISH 009 - HISPANIC CIVILIZATION (UC:CSU) - 3.00 UNITS

ADVISORY: English 28 and 67 or equivalent. DESCRIPTIONS: Open to all students. Required of all Spanish Majors; recommended for all Spanish students. Lectures and discussions in English.

1239	LEC	12:10 pm - 1:35 pm	M W	RIVERA, M A	DH 307
------	-----	--------------------	-----	-------------	--------

SPANISH 035 - SPANISH FOR SPANISH SPEAKERS I (UC:CSU) - 5.00 UNITS

ADVISORY: English 28 and 67 or equivalent. The bilingual student practices written Spanish with an emphasis on the acquisition of a solid grammatical base, vocabulary enrichment, and spelling. Addresses all four skills in Spanish, but focuses on reading and writing. Includes readings on the geography, customs and culture of Spain and Latin America.

3589	LEC	6:50 pm - 9:20 pm	M W	VILLEGAS, M E	DH 309
AND	LAB	- 0:55 hrs	TBA	STAFF	DH 319

SPEECH
 Chair: Jeanne Dunphy, CC187 (323) 953-4000 ext. 2967
<http://catalog.lacitycollege.edu/pages/speech.html>

SPEECH 071 - SPEAKING ENGLISH AS A SECOND LANGUAGE I (NDA) - 3.00 UNITS

PREREQUISITE: ESL 3A/3B/3C with a satisfactory grade or appropriate ESL placement score. May not be taken concurrently with any other 3 unit Speech class. COREQUISITE: Students in Speech 71 must also enroll in Speech 60A. DESCRIPTION: A level four course for persons who use English as a second language. Stresses the most common words in English, their pronunciation and usage.

0575	LEC	9:00 am - 12:10 pm	F	MACPHERSON, S	AD 204
1271	LEC	10:35 am - 12:00 pm	M W	KAHN, R A	AD 204
3268	LEC	6:50 pm -10:00 pm	W	PALLOS, C	AD 203
3602	LEC	6:50 pm -10:00 pm	T	PALLOS, C	CCW 256

SECTION#	TIME	DAYS	INSTRUCTOR	LOCATION			
The Fall 2010 Schedule of Classes identifies the section numbers for every Speech 60A, 60B, 60C and 60D class. You can consult the chart below to see what block of time is allotted to each of the sections. Students enrolled in Speech 71, 72, 73, and 113 must also register in one of the following sections. Consult with your instructor for further guidance. Although you are required to attend only 30 minutes per week, you must attend within the block of time assigned to your section.							
60A	60B	60C	60D	61	TIME	DAYS	INSTR
8501	8502	8503	0162	1273	7:25–8:50 a.m.	MW	Bunn
8535	8522	8530	0166	1274	7:25–8:50 a.m.	TTH	Bunn
8525	8526	8527	0163	1280	9:00–10:25 a.m.	MW	Hendricks
8540	8520	8524	0183	1277	9:00–10:25 a.m.	TTH	Beaufait
8552	8569	8554	0179	1285	10:35 a.m.–12:00 p.m.	MW	Hendricks
8521	8529	8538	0189	1278	10:35 a.m.–12:00 p.m.	TTH	Bunn
0197	8533	8534	0201	1281	1:45–3:10 p.m.	MW	Beaufait
8528	8537	8541	0196	3261	1:45–3:10 p.m.	TTH	Bunn
0157	8574	8576	3014	1284	12:00–1:35 p.m.	MW	Beaufait
8564	8565	8568	3008	3270	9:00 a.m.–12:10 p.m.	S	Davis
8542	8543	8544	3013	3260	3:30–6:40 p.m.	M	Baba
8532	0158	0199	0128	0202	3:30–6:40 p.m.	T	Beaufait
8581	8582	8583	3016	3274	12:10–1:35 p.m.	TTH	Davis
8560	8562	8563	3015	3265	6:50–10:00 p.m.	T	Baba

SPEECH 072 - SPEAKING ENGLISH AS A SECOND LANGUAGE II (NDA) - 3.00 UNITS

PREREQUISITE: Successful completion of Speech 71 and Speech 60A, or appropriate ESL placement score and concurrent enrollment in ESL 5A and 5B. May not be taken concurrently with any other 3 unit Speech class. COREQUISITE: Students in Speech 72 must also enroll in Speech 60B. DESCRIPTION: A level five course for persons who use English as a second language. Stresses expanding vocabulary utilizing the most common English words, their pronunciation and usage, along with usage of idiomatic expression, figurative language, etc. Develops skills in listening.

0210	LEC	9:00 am - 10:25 am	MW	KAHN, R A	HH 205
1272	LEC	9:00 am - 10:25 am	T Th	BUNN, H M	BUNG 11
3271	LEC	6:50 pm -10:00 pm	T	GALINDO, N R	HH 107

SPEECH 073 - SPEAKING ENGLISH AS A SECOND LANGUAGE III (NDA) - 3.00 UNITS

PREREQUISITE: Successful completion of Speech 72 and Speech 60B or appropriate ESL placement score and concurrent enrollment in ESL 6A. May not be taken concurrently with any other speech class. COREQUISITE: Students in Speech 73 must also enroll in Speech 60C. DESCRIPTION: A level six intensive Speech course for persons who use English as a second language who may have adequate reading and grammatical skills but need more help in articulation, punctuation, and oral composition.

0532	LEC	9:00 am - 10:25 am	MW	BUNN, H M	AD 301B
0533	LEC	10:35 am - 12:00 pm	T Th	BEAUFIT, K B	DH 306
1282	LEC	9:00 am - 12:10 pm	F	REGINA, M A	JH 109

SPEECH 101 - ORAL COMMUNICATION I (UC:CSU) - 3.00 UNITS

ADVISORY: English 101 or 28 and 67 with a satisfactory grade, or appropriate placement score. ESL students are strongly advised to complete Speech Communication 111 and 113 with a satisfactory grade or better. Speech 101 is a Public Speaking course which gives students techniques and practice in Informative and Persuasive extemporaneous public speaking performances utilizing effective outlining, structure and style.

0573	LEC	9:00 am - 12:10 pm	F	BATES, B E	AD 306
1248	LEC	9:00 am - 12:10 pm	S	WHITWORTH, M T	AD 301A
1251	LEC	7:25 am - 8:50 am	T Th	BATES, B E	AD 203
1253	LEC	12:10 pm - 1:35 pm	T Th	KARLSEN, T O	AD 203
1257	LEC	1:45 pm - 3:10 pm	MW	HAAS, H T	AD 203
1258	LEC	10:35 am - 12:00 pm	MW	DUNPHY, J S	JH 205
1259	LEC	10:35 am - 12:00 pm	T Th	HENDRICKS, S L	AD 301A

SECTION#	TIME	DAYS	INSTRUCTOR	LOCATION
1260	LEC	10:35 am - 12:00 pm	T Th	SPILIOS, J B AD 303
1262	LEC	12:10 pm - 1:35 pm	MW	HAAS, J T AD 203
1275	LEC	1:45 pm - 3:10 pm	T Th	KARLSEN, T O AD 203
1276	LEC	9:00 am - 10:25 am	T Th	SPILIOS, J B AD 303
1578	LEC	9:00 am - 10:25 am	MW	KAHN, R A LS 110
3604	LEC	6:50 pm -10:00 pm	T	KENNEDY, K A BUNG 2A
3606	LEC	3:30 pm - 6:40 pm	W	MODISSETT, N F AD 204
3623	LEC	6:50 pm -10:00 pm	M	KALUSTIAN, M CCW 256
8471	LEC	10:35 am - 12:00 pm	T Th	HENDRICKS, S L AD 301A

SPEECH 104 - ARGUMENTATION (UC:CSU) - 3.00 UNITS

PREREQUISITE: Speech Communication 101 and English 101 with a satisfactory grade. DESCRIPTION: A critical thinking class in logical reasoning strategies of argument and rational thinking skills to construct and analyze arguments. Meets AA degree and transfer requirements in critical and analytic thinking.

1607	LEC	9:00 am - 10:25 am	MW	SHERWOOD, K G	AD 301A
------	-----	--------------------	----	---------------	---------

SPEECH 106 - FORENSICS (CSU) - 2.00 UNITS Rpt 3

Students develop the skills to research, prepare, and competitively deliver oral arguments in a debate or individual event at intercollegiate forensics tournaments.

0224	LEC	- 3:10 hrs	TBA	STAFF	CC 185
AND	LAB	- 3:10 hrs	TBA	STAFF	CC 185

SPEECH 111 - VOICE AND ARTICULATION (CSU) - 3.00 UNITS

ADVISORY: ESL students: English 28 or equivalent, and Speech Communication 113 with a satisfactory grade or better. May not be taken concurrently with Speech 113. DESCRIPTION: Study and practice of the best methods of voice development, speech sound production, pronunciation, articulation, and prosody.

1621	LEC	7:25 am - 8:50 am	T Th	HENDRICKS, S L	AD 301B
3612	LEC	6:50 pm -10:00 pm	M	AUGUSTE, N C	AD 303

SPEECH 113 - ENGLISH SPEECH AS A SECOND LANGUAGE (CSU) - 3.00 UNITS Rpt 1

ADVISORY: Speech 73 and Speech 60C and ESL 6A with a satisfactory grade or appropriate placement score. DESCRIPTION: For speakers of English as a second language. May be taken twice for credit. May NOT be taken concurrently with any other Speech class. COREQUISITE: Students in Speech 113 must also enroll in Speech 60D. DESCRIPTION: Stresses the speaking of standard American English, including pronunciation, diacritics and/or phonetics, dictionary use, idiomatic expressions, phraseology, rhythm, inflection, and vocabulary building.

0181	LEC	8:50 am - 12:10 pm	S	AUGUSTE, N C	AD 204
1266	LEC	9:00 am - 10:25 am	MW	BEAUFIT, K B	AD 303
1283	LEC	9:00 am - 10:25 am	T Th	HENDRICKS, S L	AD 301A
3610	LEC	6:50 pm -10:00 pm	W	GROVER, M C	AD 203

SPEECH 121 - THE PROCESS OF INTERPERSONAL COMMUNICATION (UC:CSU) - 3.00 UNITS

ADVISORY: English 28 or equivalent and for ESL students Speech Communication 113 with a satisfactory grade or better. DESCRIPTION: Meets CSU transfer certification requirements. Speech communication interaction involving 2 to 5 people. Classroom exercises and experimentation provide understanding of self-concept, perception, feedback, language, nonverbal communication, and listening.

1268	LEC	10:35 am - 12:05 pm	T Th	DUNPHY, J S	CHEM 201
Special tutorial assistance available to students in section 1268.					
3611	LEC	6:50 pm -10:00 pm	W	DUNPHY, J S	JH 207

SPEECH 130 - INTRODUCTION TO ORAL INTERPRETATION OF LITERATURE (UC:CSU) - 3.00 UNITS

ADVISORY: English 28 and 67 with a satisfactory grade, or appropriate placement score. Students use oral interpretation to express the printed word. Stresses techniques of discovering an author's meaning and expressing those meanings to an audience through reading aloud.

0211	LEC	10:35 am - 12:00 pm	MW	DUNPHY, J S	HH 7
------	-----	---------------------	----	-------------	------

SECTION# TIME DAYS INSTRUCTOR LOCATION

SPEECH 162 - COMMUNICATION DISORDERS (CSU) - 3.00 UNITS

PREREQUISITE: Speech 111 and Speech 121. DESCRIPTION: Introduction to communication disorders such as stuttering, voice, articulation, neurological disorders in children and adults.

3031 LEC 6:50 pm -10:00 pm T HENDRICKS, S L AD 303

SPEECH 185 - DIRECTED STUDY - SPEECH COMMUNICATION (CSU) - 1.00 UNITS Rpt 2

8546 LEC - 1:00 hrs TBA DUNPHY, J S CC 187

SPEECH 285 - DIRECTED STUDY - SPEECH COMMUNICATION (CSU) - 2.00 UNITS

8547 LEC - 2:05 hrs TBA DUNPHY, J S CC 187

SPEECH 385 - DIRECTED STUDY - SPEECH COMMUNICATION (CSU) - 3.00 UNITS

8548 LEC - 3:10 hrs TBA DUNPHY, J S CC 187

SUPERVISED LEARNING ASSISTANCE

Chair: Maryanne Des Vignes, LIB103C (323) 953-4000 ext 2770
<http://www.lacitycollege.edu/citymain/academic.html#SUBJECT/AREA>

SUPERVISED LEARNING ASSISTANCE 001T - SUPERVISED LEARNING ASSISTANCE (NDA) - 0.00 UNITS Rpt 9

5950 -22:15 hrsTBA DES VIGNES, M LRC 103A
5951 -22:15 hrsTBA DES VIGNES, M LRC 103A
8950 -22:15 hrsTBA DES VIGNES, M LRC 103A
8951 -22:15 hrsTBA SOTIRIOU, P E CCW 259
8956 -22:15 hrsTBA MATRANGA, S B LRC 103A
8958 -22:15 hrsTBA ADELEYE, A LRC 103A
8959 -22:15 hrsTBA ADELEYE, A LRC 103A
8961 -22:15 hrsTBA SMITH, A L LRC 103A
8962 -22:15 hrsTBA MATRANGA, S B LRC 103A
8964 -22:15 hrsTBA DES VIGNES, M LRC 103A
8967 -22:15 hrsTBA SMITH, A L LRC 103A

SUPERVISION

Chair: Thelma Day, AD304 323-953-4000 ext. 2541
<http://www.lacitycollege.edu/academic/departments/busad/index.html>

SUPERVISION 001 - ELEMENTS OF SUPERVISION (CSU) - 3.00 UNITS

ADVISORY: English 28 or equivalent. DESCRIPTION: This course is designed to develop leadership ability for those in supervisory positions in business and industry.

3615 LEC - 3:10 hrs TBA HASTEY, R B ON LINE
hasteyrb@lacitycollege.edu

3616 LEC 6:50 pm -10:00 pm T Th EGREGOR, A E DH 303
(8 Week Class - Starts 10/25/2010, Ends 12/19/2010)

SUPERVISION 012 - WRITTEN COMMUNICATIONS FOR SUPERVISORS - 3.00 UNITS

ADVISORY: English 28/31 or equivalent. DESCRIPTION: This course teaches the fundamentals of written communications, aimed at managers and supervisors. Includes principles of business letter writing, audience analysis, preparation of memos, reports and technical documentation.

3206 LEC 6:50 pm -10:00 pm M SCHENCK, L R AD 316

SECTION# TIME DAYS INSTRUCTOR LOCATION

TELEVISION - (See Cinema)

Chair: Vaughn Obern, CC181 (323) 953-4000 ext. 2627
<http://cinematv.lacitycollege.edu/>
obernvg@lacitycollege.edu

TELEVISION 001 - INTRODUCTION TO TELEVISION (CSU) - 3.00 UNITS

Students study what's on Television and why, including the history of Radio and Television Broadcasting. They also learn costs, ratings, profits, the FCC rules, cable and pay Television. Recommended elective for Journalism, Theater and Public Relations. NOTE: Students will be dropped or may not enroll if not present at the first class session.

3618 LEC 6:50 pm -10:00 pm W JONES, D L CC 149

TELEVISION 004 - TELEVISION CAMERA LIGHTING AND SOUND - 3.00 UNITS

An introduction to Camera, Lighting and Sound for video and film in studio and on location. NOTE: Students will be dropped or may not enroll if not present at the first class session.

1919 LEC 12:10 pm - 3:20 pm T MENDEZ, R J CC 132

TELEVISION 006 - STUDIO AND REMOTE PRODUCTION - 3.00 UNITS Rpt 1

Prerequisite: TV 46 with a satisfactory grade of better. ADVISORY: Cinema 2. Students light and shoot remote setups then edit those pieces for inclusion into a half hour live to tape production in the studio. NOTE: Students will be dropped or may not enroll if not present at the first class session. TV 6 & 7 are taught simultaneously during the same class session and it is not possible to enroll in both classes.

5431 LEC 5:15 pm - 6:10 pm W MENDEZ, R J CC 125
AND LAB 6:15 pm - 9:25 pm W MENDEZ, R J CC 125

TELEVISION 007 - TELEVISION ANNOUNCING I (CSU) - 3.00 UNITS Rpt 1

Students create and write a number of stories as part of training in Television announcing for broadcast news, sports, weather and commercials. They act as on-camera talent in production of a half hour in-studio live-to-tape production. NOTE: Students will be dropped or may not enroll if not present at the first class session. TV 6 & 7 are taught simultaneously during the same class session and it is not possible to enroll in both classes.

5432 LEC 5:15 pm - 6:10 pm W MENDEZ, R J CC 125
AND LAB 6:15 pm - 9:25 pm W MENDEZ, R J CC 125

TELEVISION 009 - TV EQUIPMENT (CSU) - 3.00 UNITS

ADVISORY: Television 4. Students learn the principles and operation of a television control room and studio equipment leading to the production of their own live-switched one-minute commercial. Sound control, studio lighting, control room procedures, video camera operation, directing, script writing, storyboarding, and production design are emphasized.

1620 LEC 12:10 pm - 3:20 pm Th MENDEZ, R J CC 132

TELEVISION 025 - TELEVISION AND FILM DRAMATIC WRITING (CSU) - 3.00 UNITS Rpt 1

Advisory: English 21. Professional methods and techniques of television writing for drama and comedy for film and tape are studied. It also deals with getting an agent and how scripts are sold. NOTE: Students will be dropped or may not enroll if not present at the first class session.

3622 LEC 6:50 pm -10:00 pm T GENDELMAN, M M CC 149

TELEVISION 046 - TELEVISION PRODUCTION (CSU) - 3.00 UNITS Rpt 1

Prerequisite: Television 9 with a satisfactory grade or better. ADVISORY: Television 4. (Required of all Television Majors.) Students write, produce, and direct a series of three live-switched productions beginning with a 30-second commercial followed by two longer and more complex television programs. They function as talent or crew in productions produced by classmates. Each student learns production protocol; operation of studio cameras; lighting instruments and control; and operation of control room equipment including switcher, audio mixer, video recording, and character

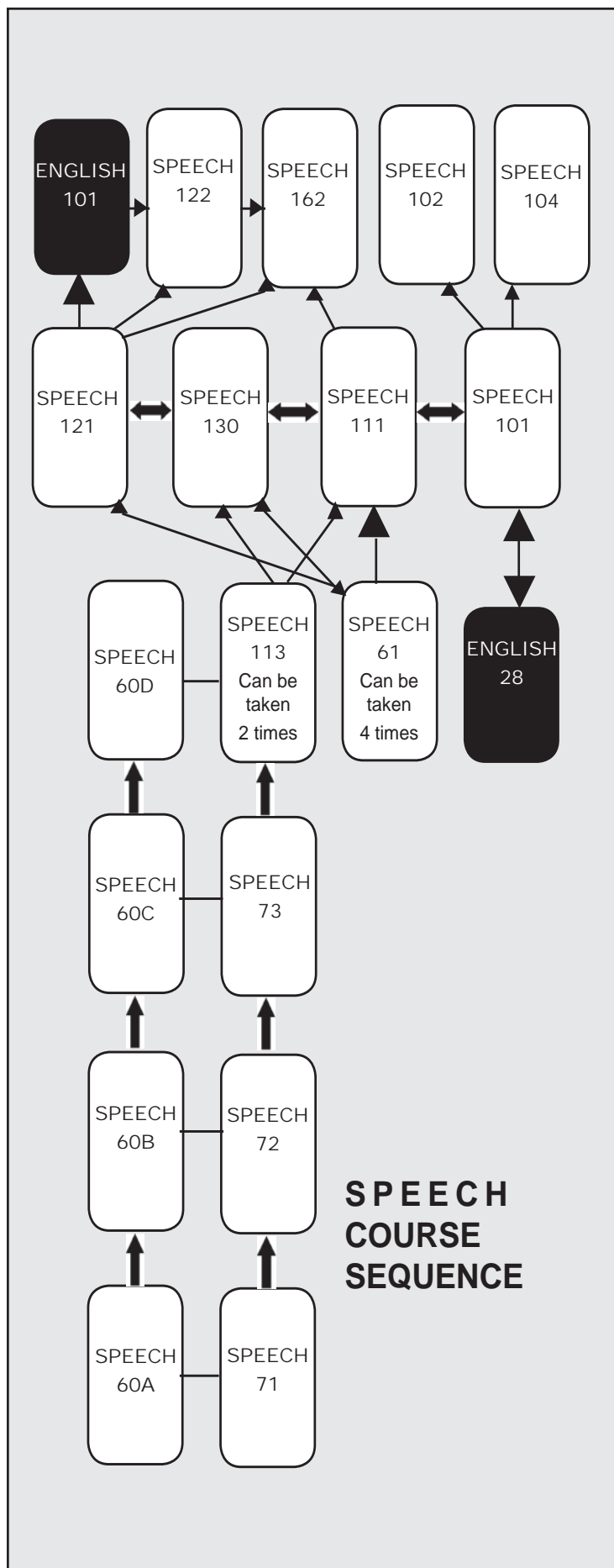

generator. NOTE: Students will be dropped or may not enroll if not present at the first class session.

3650	LEC	6:00 pm - 8:05 pm	M	MENDEZ, R J	CC 132
AND	LAB	8:05 pm -10:10 pm	M	MENDEZ, R J	CC 132

TELEVISION 055 - DIGITAL VIDEO PRODUCTION WORKSHOP I - 3.00 UNITS Rpt 1

Prerequisite: Cinema 1, 2 and TV 4, 9 with a satisfactory grade or better. Intermediate film and television students will produce short video projects using basic digital video cameras and editing systems. (Same as Cinema 33.) NOTE: Enrolled students will be dropped and non-enrolled students may not add if not present at the first class session.

5196	LEC	5:15 pm - 6:15 pm	T	VARNER, J K	CC 118
AND	LAB	6:15 pm -10:35 pm	T	VARNER, J K	CC 118
8551	LEC	12:10 pm - 1:10 pm	Th	VARNER, J K	CC 118
AND	LAB	1:10 pm - 5:30 pm	Th	VARNER, J K	CC 118

TELEVISION 185 - DIRECTED STUDY - TELEVISION (CSU) - 1.00 UNITS Rpt 2

(Credit/No Credit) Prerequisite: Television 46 with satisfactory grades or better. Courses limited to advanced LACC Television Students. Conference one hour per unit. Allows students to pursue Directed Study in Television on a contract basis under the direction of a supervising instructor.

8293	LEC	9:00 am - 9:55 am	W	OBERN, V G	CC 260
------	-----	-------------------	---	------------	--------

THEATER
 Chair: Kevin Morrisen, TA208 (323) 953-4000 ext. 2992
<http://theatreacademy.lacitycollege.edu/>

THEATER 100 - INTRODUCTION TO THE THEATER (UC:CSU) - 3.00 UNITS

ADVISORY: English 101. A survey study of the various elements of the theatre.
 1292 LEC 9:00 am - 10:25 am M W SSKO, D B THEA 218

THEATER 105 - DRAMA DIGEST (CSU) - 1.00 UNITS Rpt 3

DESCRIPTION: Required of theatre majors each semester of attendance. The student's theatrical experience is enriched through the observation of regularly scheduled programs consisting of acting scenes and exercises from the various theatre classes.
 1293 LEC - 0:50 hrs TBA FATE, R F THEA 161

THEATER 110 - HISTORY OF THE WORLD THEATER (UC:CSU) - 3.00 UNITS

ADVISORY: English 101 or equivalent. History of theatre from its primitive beginnings to the present. FALLO6-DEPT CLASS
 1294 LEC 10:20 am - 1:30 pm F STAFF AD203

THEATER 200 - INTRODUCTION TO ACTING (UC:CSU) - 3.00 UNITS

DESCRIPTION: Through lecture, discussion, demonstration, and limited participation exercises, the student is introduced to the art and craft of acting.
 1295 LEC 9:00 am - 10:25 am T Th HOGAN, E A THEA 102
 3657 LEC 3:30 pm - 6:40 pm M FATE, R F AD305

THEATER 240 - VOICE AND ARTICULATION FOR THE THEATER (UC:CSU) - 3.00 UNITS

1299 LEC 8:00 am - 8:50 am M W F FAIRBANKS, C THEA 161

THEATER 285 - DIRECTED STUDY - THEATER (CSU) - 2.00 UNITS

5211 LEC - 2:05 hrs TBA FATE, R F THEA 218
 8556 LEC - 2:05 hrs TBA ROSSI, A A THEA 161

THEATER 300 - INTRODUCTION TO STAGE CRAFT (UC:CSU) - 3.00 UNITS

ADVISORY: English 28 or equivalent. DESCRIPTION: Survey of the technical areas of play production.
 0110 LEC 11:00 am - 12:05 pm T Th MOODY, J L AD201
 AND LEC - 0:40 hrs TBA MOODY, J L AD201

SECTION# TIME DAYS INSTRUCTOR LOCATION

THEATER 315 - INTRODUCTION TO THEATRICAL SCENIC DESIGN (UC:CSU) - 3.00 UNITS

Students develop a visual graphic vocabulary in order to express design concepts for scenic environments. Students analyze specific text or events and create graphic documentation in order to communicate ideas and visual concepts. Class projects focus on specific skills and forms of design presentations; script analysis, ground plan and section, elevations, details, model building and computer pre-visualization of virtual environments.

0103 LEC 9:00 am - 11:10 am F MORRISSEY, K L AD 201
AND LAB 11:10 am - 12:10 pm F MORRISSEY, K L AD 201
AND LAB - 0:50 hrs TBA MORRISSEY, K L AD 201

THEATER 325 - STAGE MANAGEMENT AND ADVANCED STAGE CRAFT (UC:CSU) - 4.00 UNITS Rpt 3

DESCRIPTION: Intensive study of stage craft and other related technical phases of the theatre.

1318 LEC 9:00 am - 9:55 am T Th MOODY, J L AD201
AND LAB 9:55 am - 10:50 am T Th MOODY, J L AD201

THEATER 335 - APPLIED STAGE MANAGEMENT AND PRODUCTION (UC:CSU) - 4.00 UNITS Rpt 3

ADVISORY: English 28. DESCRIPTION: Practical assignments are made in technical and managerial phases of plays prepared for public presentation.

8557 LAB - 12:05 hrs TBA STAFF THEA 113

THEATER 336 - APPLIED STAGE MANAGEMENT & PRODUCTION LAB (NDA) - 3.00 UNITS Rpt 3

0133 LEC - 3:10 hrs TBA MORRISSEY, K L THEA 106

THEATER 385 - DIRECTED STUDY - THEATER (CSU) - 3.00 UNITS

Theater students pursue on their own an in-depth study of a subject of special interest in the field of theater. Consultation with the instructor on a weekly basis, plus independent work is required.

5212 - 3:10 hrs TBA FATE, R F THEA 218

THEATER 400 - COSTUME PERIODS AND STYLES (UC:CSU) - 3.00 UNITS

ADVISORY: English 28.

3330 LEC 6:50 pm - 10:00 pm Th BLEDSOE, J E THEA 218

THEATER 414 - COSTUME DRAPING AND ACCESSORIES - 3.00 UNITS Rpt 1

Theory and practice of creating stage and film costumes and costume accessories through draping.

0138 LEC 9:00 am - 10:50 am T SSKO, D B THEA 113
AND LAB 10:50 am - 12:40 pm T SSKO, D B THEA 113

THEATER 419 - ADVANCED COSTUME ILLUSTRATION - 3.00 UNITS Rpt 1

Advanced costume illustration for theater and film, including; advanced figure drawing, sketch artist techniques, computer illustration, rendering textures and creating finished costume plates.

0153 LEC 9:00 am - 11:10 am Th BLEDSOE, J E THEA 113
AND LAB - 1:00 hrs TBA BLEDSOE, J E THEA 113
AND LAB 11:10 am - 12:00 pm Th BLEDSOE, J E THEA 113

THEATER 425 - APPLIED COSTUMING FOR THE THEATER (CSU) - 4.00 UNITS Rpt 3

PREREQUISITE: English 28.

8559 LAB - 12:05 hrs TBA MOODY, J L THEA 113

THEATER 426 - APPLIED COSTUMING FOR THE THEATER LAB (NDA) - 3.00 UNITS Rpt 3

CO-REQUISITE: Theater 425.

1317 LAB - 3:10 hrs TBA BLEDSOE, J E THEA 113

SECTION# TIME DAYS INSTRUCTOR LOCATION

THEATER 450 - BEGINNING STAGE MAKE-UP (UC:CSU) - 2.00 UNITS

DESCRIPTION: Principles of makeup for the theatre.

0695 LEC 10:05 am - 10:35 am T Th STAFF THEA 106
AND LAB 10:35 am - 12:10 pm T Th STAFF THEA 106

THEATER 941 - COOPERATIVE EDUCATION - THEATER (CSU) - 4.00 UNITS Rpt 3

9147 - 4:15 hrs TBA WERBLE, D M AD 209

THEATER ACADEMY
Chair: Kevin Morrissey, TA208 (323) 953-4000 ext. 2992
<http://theatreacademy.lacitycollege.edu/>

THEATER 185 - DIRECTED STUDY - THEATER (CSU) - 1.00 UNITS Rpt 2

DESCRIPTION: Allows students to pursue Directed Study on a contract basis under the direction of a supervising instructor. Refer to the "Directed Study" section of this catalog for additional information.

8555 LEC 12:30 pm - 1:30 pm Th STAFF THEA 161

THEATER 205 - ACTOR'S ORIENTATION TO PROFESSIONAL THEATER (CSU) - 2.00 UNITS Rpt 1

CO-REQUISITE: Theatre Arts 270 or consent of instructor. DESCRIPTION: A survival course with emphasis on the business of being a working professional actor.

1296 LEC 11:40 am - 2:50 pm W ROSSI, A A THEA 102

THEATER 210 - INTRODUCTION TO ORAL INTERPRETATION OF DRAMATIC LITERATURE (UC:CSU) - 3.00 UNITS Rpt 1

PREREQUISITE: Theatre Arts 270 or consent of instructor. DESCRIPTION: A study of the techniques of oral interpretation including phrasing, inflection, work relish, verse scansion, tempo and rhythm - designed to develop the actor's interpretive skills.

1310 LEC 10:05 am - 11:30 am M W ROUNTREE, J J THEA 102

THEATER 225 - BEGINNING DIRECTION (UC:CSU) - 3.00 UNITS

PREREQUISITE: Theatre 270 or consent of instructor. FALL06-DEPT CLASS

1298 LEC 1:05 pm - 2:30 pm M FERREIRA, L W THEA 218
AND LEC 1:05 pm - 2:30 pm F FERREIRA, L W THEA 161

THEATER 232 - PLAY PRODUCTION (UC:CSU) - 2.00 UNITS Rpt 3

The student is given the opportunity to work intensely in one or more areas associated with production: acting, voice, movement, management, costuming or technical theater. Students must be prepared to work irregular hours.

1320 AND LAB - 6:30 hrs TBA ROUNTREE, J J THEA 161

THEATER 242 - VOICE DEVELOPMENT WORKSHOP (CSU) - 3.00 UNITS Rpt 3

CO-REQUISITE: Theater Arts 270. DESCRIPTION: Vocal quality, strength, flexibility, control, and awareness are emphasized in group and individual exercises.

1300 LAB 8:00 am - 8:50 am M W F ROUNTREE, J J THEA 102
AND LAB 8:00 am - 8:50 am T Th FATE, R F THEA 161
1301 LAB 9:00 am - 9:50 am M W ROUNTREE, J J THEA 161
AND LAB 9:00 am - 9:50 am F ROUNTREE, J J THEA 218
AND LAB 8:00 am - 8:50 am T Th FERREIRA, L W THEA 102
1302 LEC 9:00 am - 9:50 am M W F FATE, R F THEA 102
AND LEC 9:00 am - 9:50 am T Th KRONIS, T A THEA 161

THEATER 270 - BEGINNING ACTING (UC:CSU) - 3.00 UNITS

CO-REQUISITE: Theater 100, 105, 242, 277, and 345.

1303 LEC 10:40 am - 11:30 am M W F FERREIRA, L W THEA 218
AND LAB 11:30 am - 12:45 pm M W F FERREIRA, L W THEA 218

SECTION#	TIME	DAYS	INSTRUCTOR	LOCATION
----------	------	------	------------	----------

THEATER 272 - INTERMEDIATE APPLIED ACTING (UC:CSU) - 3.00 UNITS

CO-REQUISITE: Theater 270. DESCRIPTION: The acting principles studied in Beginning Acting are expanded and applied in staged scenes.

1305	LEC	10:25 am - 12:30 pm	M W F	FATE, R F	THEA 161
------	-----	---------------------	-------	-----------	----------

THEATER 274 - ADVANCED APPLIED ACTING (UC:CSU) - 3.00 UNITS Rpt 1

PREREQUISITE: Theater 272. DESCRIPTION: The student is engaged in greater in depth analysis of staged scenes. Emphasis is placed upon the rehearsal process and rehearsal techniques.

1306	LAB	10:05 am - 1:15 pm	T	ROSSI, A A	THEA 161
AND	LAB	10:05 am - 12:10 pm	Th	ROSSI, A A	THEA 161
AND	LAB	- 0:50 hrs	TBA	ROSSI, A A	THEA 161

THEATER 275 - SCENE STUDY (CSU) - 2.00 UNITS Rpt 3

PREREQUISITE: Theater 270 or consent of instructor. DESCRIPTION: The student is engaged in greater in-depth analysis of staged scenes. Emphasis is placed upon the rehearsal process and techniques.

1307	LEC	9:30 am - 12:40 pm	F	GREEN, D T	THEA 102
------	-----	--------------------	---	------------	----------

THEATER 276 - ACTORS' WORKSHOP (CSU) - 3.00 UNITS Rpt 3

PREREQUISITE: Theatre 270.

1308	LAB	10:05 am - 1:15 pm	T	PIDAY, M L	THEA 218
AND	LAB	10:05 am - 12:10 pm	Th	PIDAY, M L	THEA 218
AND	LAB	- 1:05 hrs	TBA	PIDAY, M L	THEA 218

THEATER 277 - CHARACTER ANALYSIS (UC:CSU) - 3.00 UNITS Rpt 1

CO-REQUISITE: Theatre 270 or consent of the instructor.

1309	LEC	10:35 am - 12:00 pm	M W	PIDAY, M L	AD305
------	-----	---------------------	-----	------------	-------

THEATER 294 - REHEARSALS AND PERFORMANCES (UC:CSU) - 2.00 UNITS Rpt 3

PREREQUISITE: Theater 270. DESCRIPTION: Experience is given in the acting, directing, and producing of plays for public presentation. Students are required to furnish three glossy photographs - eight by ten inches in size.

1311	LAB	- 13:15 hrs	TBA	ROSSI, A A	THEA 102
------	-----	-------------	-----	------------	----------

THEATER 295 - REHEARSALS AND PERFORMANCES LAB (NDA) - 0.00 UNITS Rpt 3

PREREQUISITE: Theater 294 and 274 or 276.

0116	LEC	- 3:10 hrs	TBA	ROSSI, A A	THEA 161
------	-----	------------	-----	------------	----------

THEATER 345 - TECHNICAL STAGE PRODUCTION (UC:CSU) - 4.00 UNITS Rpt 3

CO-REQUISITE: Theater 270. DESCRIPTION: This course offers practical technical experience related to the preparing and mounting of theatrical productions for a paying audience. Specific assignments will be made requiring additional hours.

1314	LAB	- 13:15 hrs	TBA	STAFF	THEA 135
------	-----	-------------	-----	-------	----------

THEATER 346 - TECHNICAL STAGE PRODUCTION LAB (NDA) - 3.00 UNITS Rpt 3

CO-REQUISITE: Theater 345.

1289	LEC	-		MOODY, J L	THEA 135
------	-----	---	--	------------	----------

SECTION#	TIME	DAYS	INSTRUCTOR	LOCATION
----------	------	------	------------	----------

THEATRE ACADEMY CLASSES

THEATRE ACADEMY CLASSES

The Los Angeles Theatre Academy at Los Angeles City College has firmly established itself as one of the most accomplished and highly respected professional theatre training institutions in the United States.

Since being established in 1929, the Academy has been dedicated to developing the skills, crafts and attitudes of students to prepare them for careers in the professional theatre.

PROFESSIONAL TRAINING FOR THE ACTOR

The training that the Los Angeles Theatre Academy students receive is stimulating, broadening, exacting and intense. A limited number of openings are available each fall and spring semester to those acting students who are highly motivated, aggressive, exceptionally talented, and responsible. An acting student admitted into the Academy is signifying complete dedication to study, work and performance so that the standard of excellence of the Theatre Academy is continually maintained.

Acceptance into the competitive, highly selective acting program is by audition and interview only. Specific information concerning entrance requirements is available in the Theatre Production Office (Theatre Building - Room 208). Please note that any actor interested in pursuing training at the Los Angeles Theatre Academy must exhibit competence in spoken English. Those actors with pronounced dialects and regional accents who are accepted into the Academy will be required to spend extra time over the course of their training in the Speech Lab so that lack of understanding or articulation does not become a hindrance. Training at the Academy requires enrollment in the Fall Semester, Winter Intersession, and Spring Semester.

ACTING STUDENTS:

Block Program for 1st Semester

- TA 100 - Introduction to the Theater
- TA 105 - Drama Digest
- TA 242 - Voice Development Workshop (Voice and Movement)
- TA 270 - Beginning Acting
- TA 300 - Introduction to Stagecraft
- TA 345 - Technical Stage Production
- TA 346 - Technical Stage Production Lab

TECHNICAL THEATRE STUDENTS:

Block Program for 1st Semester

- TA 100 - Introduction to the Theatre
- TA 105 - Drama Digest
- TA 300 - Introduction to Stagecraft
- TA 302 - Introduction to Stage Management
- TA 314 - Theatrical Sound Design Fundamentals, Procedures/Operations
- TA 335 - Applied Stage Management & Production
- TA 336 - Applied Stage Management & Production Lab

COSTUMING THEATRE STUDENTS:

Block Program for 1st Semester

- TA 105 - Drama Digest
- TA 200 - Introduction to Acting
- TA 400 - Costume Periods & Staples
- TA 416 - Material and Methods for the Costumer
- TA 420 - Costuming on Set
- TA 425 - Applied Costuming for the Theatre
- TA 426 - Applied Costuming for the Theatre Lab

Acceptance into the Technical Theatre or Costuming programs are by interview only. For further information, call (323) 953-4000 ext. 2990.

SECTION# TIME DAYS INSTRUCTOR LOCATION

NON CREDIT CLASSES

Chair: Alex Davis, CCW----- (323) 953-4000 ext. 2956
<http://www.alexanal@lacitycollege.edu>

BASIC SKILLS

BASIC SKILLS 006CE - REVIEW OF BASIC ENGLISH (NDA) - 0.00 UNITS Rpt 9

The student learns fundamental English skills and building blocks to prepare them for their English tasks in academics or in the workplace. Students learn the basics of reading comprehension, grammar and the rules of writing.

5722	LEC	1:00 pm - 3:10 pm	MW	CORDOVA, L A	TBA TBA
<i>(8 Week Class - Starts 9/6/2010, Ends 10/30/2010)</i>					
5753	LEC	7:00 pm - 9:05 pm	W	WERBLE, D M	TBA TBA
5756	LEC	2:00 pm - 4:00 pm	MTW	STAFF	TBA TBA
<i>(6 Week Class - Starts 10/18/2010, Ends 11/26/2010)</i>					
5825	LEC	- 4:15 hrs	TBA	CORSO, M E	TBA TBA
<i>(8 Week Class - Starts 10/25/2010, Ends 12/13/2010)</i>					
5829	LEC	8:30 am - 9:35 am	TTh	WATIER, E R	TBA TBA
<i>(15 Week Class - Starts 8/30/2010, Ends 12/11/2010)</i>					
5837	LEC	9:00 am - 11:05 am	S	STAFF	CCW 255
5948	LEC	2:00 pm - 4:00 pm	MTW	STAFF	TBA TBA
<i>(6 Week Class - Starts 9/6/2010, Ends 10/13/2010)</i>					
8705	LEC	9:00 am - 12:50 pm	TTh	STAFF	CCW 260
<i>(5 Week Class - Starts 8/31/2010, Ends 9/28/2010)</i>					
8711	LEC	9:00 am - 12:05 pm	TTh	CORDOVA, L A	CCW 260
<i>(6 Week Class - Starts 11/2/2010, Ends 12/11/2010)</i>					
8734	LEC	10:00 am - 12:20 pm	F	STAFF	TBA TBA
<i>(14 Week Class - Starts 8/30/2010, Ends 12/11/2010)</i>					
8740	LEC	- 5:05 hrs	TBA	STAFF	AD 301B
<i>(7 Week Class - Starts 11/1/2010, Ends 12/19/2010)</i>					
8820	LEC	- 2:03 hrs	TBA	CORSO, M E	TBA TBA
8845	LEC	-3:03 hrs	TBA	CORSO, M E	OFF CAMP
<i>(11 Week Class - Starts 10/6/2010, Ends 12/19/2010)</i>					
8926	LEC	9:00 am - 12:50 pm	TTh	STAFF	CCW 260
<i>(5 Week Class - Starts 9/30/2010, Ends 10/30/2010)</i>					

BASIC SKILLS 007CE - REVIEW OF BASIC MATH (NDA) - 0.00 UNITS

5949	LEC	12:30 pm - 3:20 pm	TTh	EK, K	TBA TBA
<i>(7 Week Class - Starts 11/1/2010, Ends 12/17/2010)</i>					
8707	LEC	12:00 pm - 2:05 pm	T	LOPEZ, R	CCW 259
8716	LEC	8:00 am - 11:20 am	TTh	ARRIOLA, P	JOB CORP
<i>(6 Week Class - Starts 11/1/2010, Ends 12/11/2010)</i>					
8723	LEC	12:00 pm - 2:20 pm	W	RODRIGUEZ, J I	SEIU INTE
<i>(14 Week Class - Starts 9/6/2010, Ends 12/8/2010)</i>					
8762	LEC	8:00 am - 11:05 am	TTh	TUFFA, A A	JOB CORP
<i>(6 Week Class - Starts 11/8/2010, Ends 12/19/2010)</i>					
8849	LEC	1:00 pm - 3:20 pm	TTh	EK, K	TBA TBA
<i>(8 Week Class - Starts 9/10/2010, Ends 10/30/2010)</i>					
8927	LEC	8:00 am - 11:50 am	TTh	ARRIOLA, P	JOB CORP
<i>(5 Week Class - Starts 9/29/2010, Ends 10/30/2010)</i>					
8931	LEC	8:00 am - 12:15 pm	TTh	ARRIOLA, P	JOB CORP
<i>(5 Week Class - Starts 8/30/2010, Ends 9/27/2010)</i>					
8932	LEC	8:00 am - 10:20 am	MWF	TUFFA, A A	JOB CORP
<i>(5 Week Class - Starts 8/30/2010, Ends 10/1/2010)</i>					
8933	LEC	8:00 am - 10:10 am	MWF	TUFFA, A A	JOB CORP
<i>(5 Week Class - Starts 10/4/2010, Ends 11/5/2010)</i>					

SECTION# TIME DAYS INSTRUCTOR LOCATION

CAREER DEVELOPMENT SKILLS

CAREER DEVELOPMENT SKILLS 238CE - BLUEPRINT FOR WORKPLACE SUCCESS (NDA) - 0.00 UNITS Rpt 9

5717	LEC	1:00 pm - 2:15 pm	TTh	CASTELLON, H G	TBA TBA
<i>(13 Week Class - Starts 9/20/2010, Ends 12/19/2010)</i>					
8721	LEC	5:00 pm - 8:50 pm	M	CORSO, M E	CCW 259
<i>(9 Week Class - Starts 9/20/2010, Ends 11/22/2010)</i>					
8722	LEC	11:00 am - 11:40 am	MTW	STAFF	CCW 258
8730	LEC	1:00 pm - 2:15 pm	MW	CASTELLON, H G	TBA TBA
<i>(13 Week Class - Starts 9/20/2010, Ends 12/19/2010)</i>					
8731	LEC	8:00 am - 12:15 pm	TWThF	CORSO, M E	JOB CORP
<i>(2 Week Class - Starts 10/12/2010, Ends 10/22/2010)</i>					
8733	LEC	8:00 am - 11:20 am	MTWThF	HILL, V M	JOB CORP
<i>(2 Week Class - Starts 9/27/2010, Ends 10/9/2010)</i>					

ENGLISH AS A SECOND LANGUAGE

ENGLISH AS A SECOND LANGUAGE 001CE - ENGLISH AS A SECOND LANGUAGE - BEGINNING I (NDA) - 0.00 UNITS Rpt 9

8702	LEC	8:55 am - 12:05 pm	M	WATIER, E R	CCW 238
8703	LEC	8:55 am - 12:05 pm	W	WATIER, E R	CCW 238

ENGLISH AS A SECOND LANGUAGE 002CE - ENGLISH AS A SECOND LANGUAGE - BEGINNING II (NDA) - 0.00 UNITS Rpt 9

5716	LEC	5:00 pm - 8:10 pm	T	LOPEZ, R	CCW 259
------	-----	-------------------	---	----------	---------

ESL CIVICS 010CE - ESL AND CIVICS 1 (NDA) - 0.00 UNITS Rpt 9

5754	LEC	- 1:40 hrs	TBA	STAFF	TBA TBA
<i>(10 Week Class - Starts 10/14/2010, Ends 12/19/2010)</i>					
8800	LEC	- 0:55 hrs	TBA	CHESHMEDZHIAN,	CCW 255
8831	LEC	10:40 am - 11:00 am	MTW	STAFF	CCW 258

ESL CIVICS 012CE - ESL AND CIVICS 3 (NDA) - 0.00 UNITS Rpt 9

8801	LEC	- 4:15 hrs	TBA	SHISHIKYAN, A S	OFF CAMP
<i>(12 Week Class - Starts 9/27/2010, Ends 12/19/2010)</i>					

ESL CIVICS 013CE - ESL AND CIVICS 4 (NDA) - 0.00 UNITS Rpt 9

5733	LEC	- 5:10 hrs	TBA	SHISHIKYAN, A S	OFF CAMP
<i>(10 Week Class - Starts 10/13/2010, Ends 12/19/2010)</i>					
8724	LEC	9:00 am - 1:00 pm	T	PARK MOON, C W	KSNR CNTR
<i>(14 Week Class - Starts 9/18/2010, Ends 12/19/2010)</i>					
8810	LEC	8:00 am - 9:25 am	TTh	CHESHMEDZHIAN,	CCW 255
8811	LEC	5:30 pm - 6:55 pm	T ThF	SHISHIKYAN, A S	HOLL YFC
<i>(12 Week Class - Starts 9/30/2010, Ends 12/19/2010)</i>					
8812	LEC	8:30 am - 10:15 am	MT	ARRELLANO, P E	JOB CORP
<i>(14 Week Class - Starts 9/13/2010, Ends 12/19/2010)</i>					
8813	LEC	9:00 am - 12:05 pm	F	PARK, P H	KOR SC
8814	LEC	10:30 am - 2:20 pm	M	AMARO, A	CCW 260
<i>(12 Week Class - Starts 9/29/2010, Ends 12/19/2010)</i>					
8816	LEC	8:00 am - 11:10 am	S	LIN, Z	CCW 257
8826	LEC	9:00 am - 12:10 pm	S	PARK, P H	OFF CAMP
8885	LEC	6:00 pm - 9:35 pm	T	CHUNG, J	KRSC CNTR
<i>(14 Week Class - Starts 9/14/2010, Ends 12/19/2010)</i>					
8944	LEC	9:35 am - 10:35 am	MTW	STAFF	CCW 258

ESL CIVICS 014CE - ESL AND CIVICS 5 (NDA) - 0.00 UNITS Rpt 9

NOTE: This is a Non-Credit, Continuing Education class; 0 units. No fee This open-entry, open-exit citizenship course teaches U.S. history and government with appropriate English structure for English as a Second Language students at skill level 5.

5804	LEC	4:00 pm - 7:00 pm	T Th	RUTA, R	TBA TBA
<i>(9 Week Class - Starts 9/18/2010, Ends 11/18/2010)</i>					

SECTION#	TIME	DAYS	INSTRUCTOR	LOCATION
5805	LEC 3:00 pm - 6:30 pm	M	AMARO, A	CCW 258 <i>(13 Week Class - Starts 9/20/2010, Ends 12/19/2010)</i>
5820	LEC 9:00 am - 12:10 pm	T	JOSHI, K	CCW 257
5830	LEC 1:00 pm - 4:10 pm	F	NEVAREZ, A	SEIU INTE
8720	LEC - 5:50 hrs	TBA	RUTA, R	TBA TBA <i>(9 Week Class - Starts 9/18/2010, Ends 11/18/2010)</i>
8725	LEC 9:00 am - 1:15 pm	Th	PARK MOON, C W	KSNR CNTR <i>(13 Week Class - Starts 9/18/2010, Ends 12/19/2010)</i>
8802	LEC 6:00 pm - 9:35 pm	T	ARRELLANO, P E	TLP CHRC
8803	LEC 5:00 pm - 8:50 pm	Th	AMARO, A	CCW 258 <i>(12 Week Class - Starts 9/20/2010, Ends 12/19/2010)</i>
8804	LEC 8:30 am - 11:40 am	S	RODRIGUEZ, J I	CCW 258
8805	LEC 10:00 am - 1:10 pm	S	ARRELLANO, P E	SEIU INTE
8806	LEC -3:58 hrs	TBA	AMARO, A	OFF CAMP <i>(13 Week Class - Starts 9/20/2010, Ends 12/19/2010)</i>
8807	LEC 8:30 am - 11:40 am	W	KALLEN, L	CCW 258
8808	LEC 8:30 am - 11:40 am	F	RODRIGUEZ, J I	CCW 257 <i>ESL CIVICS 015CE - ESL AND CIVICS 6 (NDA) - 0.00 UNITS Rpt 9</i>
5752	LEC 6:00 pm - 9:20 pm	M	ARRELLANO, P E	TLP CHRC
5802	LEC 6:00 pm - 9:10 pm	W	ARRELLANO, P E	TLP CHRC
5803	LEC 5:00 pm - 8:50 pm	T	AMARO, A	CCW 258 <i>(13 Week Class - Starts 9/20/2010, Ends 12/19/2010)</i>
8809	LEC 9:00 am - 12:10 pm	Th	JOSHI, K	CCW 257

ESL CIVICS 030CE - ENGLISH LITERACY AND CIVICS (NDA) - 0.00 UNITS Rpt 9

8713	LEC 8:30 am - 11:40 am	M W	LOPEZ, R	CCW 255
8772	LEC 9:00 am - 12:10 pm	M W	RODRIGUES, A L	CCW 259
8817	LEC 5:00 pm - 8:10 pm	T Th	SARKISSYAN, M	CCW 255

ESL CIVICS 031CE - ENGLISH LITERACY AND CIVICS (NDA) - 0.00 UNITS Rpt 9

5806	LEC 5:00 pm - 8:10 pm	M W	SARKISSYAN, M	CCW 255
5807	LEC 8:30 am - 12:35 pm	T	KALLEN, L	CCW 258
AND	LEC - 2:15 hrs	TBA	KALLEN, L	CCW 258
8700	LEC 9:00 am - 12:10 pm	M W	JOSHI, K	CCW 257
8818	LEC 5:00 pm - 8:30 pm	T Th	WATIER, E R	CCW 257

(15 Week Class - Starts 8/30/2010, Ends 12/11/2010) **VOCATIONAL**

EDUCATION 002CE - IN-HOME SUPPORTIVE SERVICE PROVIDERS (NDA) - 0.00 UNITS Rpt 9

5725	LAB - 8:00 hrs	TBA	STAFF	OFF CAMP
AND	LAB - 3:55 hrs	TBA	STAFF	OFF CAMP
<i>(11 Week Class - Starts 10/4/2010, Ends 12/19/2010)</i>				

8706	LEC 8:30 am - 1:50 pm	T	VAZQUEZ, J M	HOME WTCR
AND	LAB - 2:30 hrs	TBA	VAZQUEZ, J M	HOME WTCR
8709	LEC 8:30 am - 1:50 pm	Th	VAZQUEZ, J M	HOME WTCR
AND	LAB - 2:30 hrs	TBA	VAZQUEZ, J M	HOME WTCR
8825	LEC 8:30 am - 1:55 pm	F	VAZQUEZ, J M	HOME WTCR
AND	LAB - 2:35 hrs	TBA	VAZQUEZ, J M	HOME WTCR

VOCATIONAL EDUCATION

VOCATIONAL EDUCATION 003CE - WORKPLACE COMPUTING FOR LIMITED ENGLISH POPULATIONS (NDA) - 0.00 UNITS Rpt 9

5720	LEC 5:00 pm - 6:10 pm	W	VALENCIA, S E	COFE MNOR
AND	LAB 6:10 pm - 8:40 pm	W	VALENCIA, S E	COFE MNOR
<i>(14 Week Class - Starts 9/11/2010, Ends 12/19/2010)</i>				
5832	LEC 6:00 pm - 6:55 pm	M	VALENCIA, S E	CCW 246
AND	LAB 6:55 pm - 9:00 pm	M	VALENCIA, S E	CCW 246
8704	LEC 9:00 am - 9:50 am	M	MARQUEZ, R	CCW 246
AND	LEC 9:55 am - 12:00 pm	M	MARQUEZ, R	CCW 246
8708	LEC 9:00 am - 9:50 am	F	MARQUEZ, R	CCW 246

SECTION#	TIME	DAYS	INSTRUCTOR	LOCATION
AND	LEC 9:55 am - 12:00 pm	F	MARQUEZ, R	CCW 246
8710	LEC 1:00 pm - 2:20 pm	T	KIM, H	CCW 246
AND	LAB 2:20 pm - 5:25 pm	T	KIM, H	CCW 246
<i>(11 Week Class - Starts 10/5/2010, Ends 12/19/2010)</i>				
8797	LEC - 2:05 hrs	TBA	MARQUEZ, R	CCW 246
AND	LEC - 6:30 hrs	TBA	MARQUEZ, R	CCW 246
<i>(8 Week Class - Starts 8/30/2010, Ends 10/23/2010)</i>				

8799 LEC 6:00 pm - 7:00 pm W SARIN, S CCW 246
AND LAB 7:00 pm - 9:05 pm W SARIN, S CCW 246

8819	LEC 2:15 pm - 3:00 pm	WTh	YALAMOVA, V G	BUNG B10
AND	LAB 3:00 pm - 4:30 pm	WTh	YALAMOVA, V G	BUNG B10
<i>(11 Week Class - Starts 9/13/2010, Ends 11/27/2010)</i>				

8850 LEC 6:00 pm - 6:55 pm Th VALENCIA, S E CCW 246
AND LAB 6:55 pm - 9:00 pm Th VALENCIA, S E CCW 246

8870 LEC 6:00 pm - 7:00 pm T SARIN, S CCW 246
AND LEC 7:00 pm - 9:00 pm T SARIN, S CCW 246

8875	LEC 1:00 pm - 2:10 pm	Th	KIM, H	CCW 246
AND	LAB 2:10 pm - 4:40 pm	Th	KIM, H	CCW 246
<i>(13 Week Class - Starts 9/16/2010, Ends 12/19/2010)</i>				

8876	LEC 9:00 am - 10:10 am	S	KIM, H	CCW 246
AND	LAB 10:10 am - 12:40 pm	S	KIM, H	CCW 246
<i>(13 Week Class - Starts 9/18/2010, Ends 12/19/2010)</i>				

8934	LEC 2:15 pm - 2:55 pm	MT F	YALAMOVA, V G	BUNG B10
AND	LAB 2:55 pm - 4:15 pm	MT F	YALAMOVA, V G	BUNG B10
<i>(8 Week Class - Starts 8/30/2010, Ends 10/23/2010)</i>				

8937	LEC 2:00 pm - 3:10 pm	Th	VALENCIA, S E	COFE MNOR
AND	LAB 3:10 pm - 5:40 pm	Th	VALENCIA, S E	COFE MNOR
<i>(14 Week Class - Starts 9/11/2010, Ends 12/19/2010)</i>				

VOCATIONAL EDUCATION 054CE - VES L FOR CD 1: SPECIALIZED VOCABULARY IN DEVELOPMENTAL THEORIES (NDA) - 0.00 UNITS Rpt 9

8701	LEC - 2:05 hrs	TBA	WERBLE, D M	TBA TBA
------	----------------	-----	-------------	---------

VOCATIONAL EDUCATION 055CE - VOCATIONAL ENGLISH AS A SECOND LANGUAGE C (NDA) - 0.00 UNITS Rpt 9

8714	LEC 12:30 pm - 3:35 pm	F	WILLIAMS, W P	OFF CAMP
------	------------------------	---	---------------	----------

VOCATIONAL EDUCATION 056CE - VOCATIONAL ENGLISH AS A SECOND LANGUAGE FOR HEALTH CAREERS (NDA) - 0.00 UNITS Rpt 9

8821	LEC 1:00 pm - 3:05 pm	F	RODRIGUEZ, J I	SEIU INTE
8822	LEC 9:00 am - 11:05 am	S	KELLEY, D M	CCW 255
8823	LEC 1:00 pm - 3:05 pm	Th	RODRIGUEZ, J I	SEIU INTE

VOCATIONAL EDUCATION 078CE - VOCATIONAL ENGLISH AS A SECOND LANGUAGE B (NDA) - 0.00 UNITS Rpt 9

8712	LEC 12:30 pm - 3:35 pm	Th	WILLIAMS, W P	OFF CAMP
------	------------------------	----	---------------	----------

VOCATIONAL EDUCATION 079CE - VOCATIONAL ENGLISH AS A SECOND LANGUAGE A (NDA) - 0.00 UNITS Rpt 9

8767	LEC 12:30 pm - 3:35 pm	W	WILLIAMS, W P	OFF CAMP
8945	LEC - 4:15 hrs	TBA	TOKHALIAN, L	OFF CAMP

VOCATIONAL EDUCATION 230CE - 30 WAYS TO SHINE AS A NEW EMPLOYEE (NDA) - 0.00 UNITS Rpt 9

5707	LEC - 6:05 hrs	TBA	STAFF	TBA TBA
<i>(2 Week Class - Starts 9/6/2010, Ends 9/17/2010)</i>				

5710	LEC - 0:25 hrs	TBA	YALAMOVA, V G	TBA TBA
<i>(14 Week Class - Starts 9/13/2010, Ends 12/18/2010)</i>				

5713	LEC - 0:21 hrs	TBA	INFANTE, M	SEIU INTE
<i>(15 Week Class - Starts 9/11/2010, Ends 12/19/2010)</i>				

5732	LEC - 0:28 hrs	TBA	INFANTE, M	SEIU INTE
<i>(11 Week Class - Starts 10/7/2010, Ends 12/19/2010)</i>				

SECTION#	TIME	DAYS	INSTRUCTOR	LOCATION
5737	LEC - 1:00 hrs	TBA	MARTI, K V	OFF CAMP (5 Week Class - Starts 10/11/2010, Ends 11/10/2010)
5811	LEC - 1:00 hrs	TBA	EK, K	OFF CAMP (5 Week Class - Starts 10/13/2010, Ends 11/12/2010)
5822	LEC - 2:55 hrs	TBA	THOMPSON, A S	URBN LG (2 Week Class - Starts 10/4/2010, Ends 10/15/2010)
5824	LEC - 6:00 hrs	TBA	JULIEN, J K	OFF CAMP (1 Week Class - Starts 10/25/2010, Ends 10/29/2010)
8719	LEC - 1:00 hrs	TBA	STAFF	OFF CAMP (5 Week Class - Starts 10/11/2010, Ends 11/10/2010)
8737	LEC - 0:28 hrs	TBA	INFANTE, M	CCW 259 (11 Week Class - Starts 10/4/2010, Ends 12/19/2010)
8761	LEC 8:00 am- 8:40 am	T	STAFF	TBA TBA (8 Week Class - Starts 9/20/2010, Ends 11/14/2010)
8765	LEC - 0:18 hrs	TBA	STAFF	CCW 259
8770	LEC 2:00 pm- 2:20 pm	WTh	MORA, F P	CCW 260 (10 Week Class - Starts 9/14/2010, Ends 11/21/2010)
8834	LEC 1:00 pm- 2:15 pm	Th	CORSO, M E	OFF CAMP (5 Week Class - Starts 9/27/2010, Ends 10/25/2010)
8835	LEC 1:00 pm- 2:15 pm	T	CORSO, M E	OFF CAMP (4 Week Class - Starts 9/29/2010, Ends 10/26/2010)
8838	LEC 5:35 pm - 5:55 pm	M	WATIER, E R	CCW 257
8839	LEC 9:00 am- 3:05 pm	Th	MARTI, K V	HH 107 (1 Week Class - Starts 9/23/2010, Ends 9/23/2010)
8841	LEC 9:00 am- 3:00 pm	Th	MARTI, K V	HH 107 (1 Week Class - Starts 10/21/2010, Ends 10/21/2010)
8842	LEC 9:00 am- 3:05 pm	Th	MARTI, K V	HH 107 (1 Week Class - Starts 11/4/2010, Ends 11/4/2010)
8843	LEC 9:00 am- 3:00 pm	Th	STAFF	TBA TBA (1 Week Class - Starts 12/9/2010, Ends 12/9/2010)
8860	LEC - 1:00 hrs	TBA	SHISHIKYAN, A S	OFF CAMP (5 Week Class - Starts 9/17/2010, Ends 10/17/2010)
8868	LEC 5:30 pm- 5:45 pm	T W	ARRELLANO, P E	TLP CHRC (10 Week Class - Starts 10/13/2010, Ends 12/19/2010)
8873	LEC - 0:21 hrs	TBA	INFANTE, M	SEIU INTE (15 Week Class - Starts 9/11/2010, Ends 12/19/2010)
8902	LEC - 0:40 hrs	TBA	HILL, V M	OFF CAMP (8 Week Class - Starts 9/10/2010, Ends 10/29/2010)
8906	LEC 12:40 pm- 1:05 pm	MTWTh	THOMPSON, A S	URBN LG (4 Week Class - Starts 9/9/2010, Ends 10/2/2010)
8911	LEC - 0:20 hrs	TBA	KALLEN, L	CCW 258
8915	LEC - 0:50 hrs	TBA	STAFF	OFF CAMP (6 Week Class - Starts 11/1/2010, Ends 12/6/2010)
8919	LEC - 0:22 hrs	TBA	AMARO, A	CCW 246 (14 Week Class - Starts 9/13/2010, Ends 12/19/2010)

VOCATIONAL EDUCATION 232CE - CLOSING THE SALE (NDA) - 0.00 UNITS Rpt 9

8854	LEC - 0:40 hrs	TBA	CORSO, M E	OFF CAMP (5 Week Class - Starts 9/29/2010, Ends 10/30/2010)
------	----------------	-----	------------	--

VOCATIONAL EDUCATION 233CE - COMPLETING THE SALES TRANSACTION (NDA) - 0.00 UNITS Rpt 9

8852	LEC - 0:50 hrs	TBA	CORSO, M E	OFF CAMP (5 Week Class - Starts 9/29/2010, Ends 10/30/2010)
------	----------------	-----	------------	--

VOCATIONAL EDUCATION 234CE - EXPLAINING FEATURES AND BENEFITS (NDA) - 0.00 UNITS Rpt 9

8856	LEC - 1:10 hrs	TBA	CORSO, M E	OFF CAMP (5 Week Class - Starts 9/29/2010, Ends 10/30/2010)
------	----------------	-----	------------	--

SECTION#	TIME	DAYS	INSTRUCTOR	LOCATION
8857	LEC - 2:05 hrs	TBA	STAFF	TBA TBA (3 Week Class - Starts 10/11/2010, Ends 10/27/2010)

VOCATIONAL EDUCATION 235CE - CUSTOMER SERVICE SMARTS:GOING THE EXTRA MILE (NDA) - 0.00 UNITS Rpt

8853	LEC - 1:00 hrs	TBA	CORSO, M E	OFF CAMP (5 Week Class - Starts 9/29/2010, Ends 10/30/2010)
------	----------------	-----	------------	--

VOCATIONAL EDUCATION 236CE - JOB CLUB (NDA) - 0.00 UNITS Rpt 9

5703	LEC 1:00 PM- 1:40 pm		ARRELLANO, P E	SCIU INTE (8 Week Class - Starts 10/25/2010, Ends 12/19/2010)
5708	LEC - 0:25 hrs	TBA	YALAMOVA, V G	BUNG B10 (14 Week Class - Starts 9/13/2010, Ends 12/18/2010)
5711	LEC - 6:05 hrs	TBA	STAFF	OFF CAMP (1 Week Class - Starts 10/8/2010, Ends 10/9/2010)
5714	LEC 8:40 am- 9:20 am	T	STAFF	TBA TBA (8 Week Class - Starts 9/20/2010, Ends 11/14/2010)
5721	LEC 5:40 pm- 6:05 pm	W	INFANTE, M	CCW 259 (14 Week Class - Starts 9/11/2010, Ends 12/19/2010)
5727	LEC 1:20 pm- 1:45 pm	F	INFANTE, M	CCW 259 (14 Week Class - Starts 9/11/2010, Ends 12/19/2010)
5728	LEC - 0:20 hrs	TBA	INFANTE, M	SEIU INTE (15 Week Class - Starts 9/11/2010, Ends 12/19/2010)
5738	LEC - 1:00 hrs	TBA	MARTI, K V	OFF CAMP (5 Week Class - Starts 10/11/2010, Ends 11/10/2010)
5740	LEC - 0:21 hrs	TBA	INFANTE, M	SEIU INTE (15 Week Class - Starts 9/11/2010, Ends 12/19/2010)
5750	LEC - 0:20 hrs	TBA	INFANTE, M	SEIU INTE (15 Week Class - Starts 9/11/2010, Ends 12/19/2010)
5751	LEC - 2:55 hrs	TBA	STAFF	TBA TBA (2 Week Class - Starts 9/20/2010, Ends 10/2/2010)
5815	LEC - 1:00 hrs	TBA	EK, K	OFF CAMP (5 Week Class - Starts 10/13/2010, Ends 11/12/2010)
5819	LEC - 0:31 hrs	TBA	STAFF	CCW 260 (10 Week Class - Starts 9/14/2010, Ends 11/21/2010)
8729	LEC - 1:00 hrs	TBA	THOMPSON, A S	URBN LG (2 Week Class - Starts 10/4/2010, Ends 10/16/2010)
8738	LEC - 0:28 hrs	TBA	INFANTE, M	CCW 259 (11 Week Class - Starts 10/4/2010, Ends 12/19/2010)
8766	LEC - 0:18 hrs	TBA	STAFF	CCW 257
8786	LEC - 1:05 hrs	TBA	SHISHIKYAN, A S	AD 303 (5 Week Class - Starts 9/17/2010, Ends 10/17/2010)
8866	LEC - 1:00 hrs	TBA	SHISHIKYAN, A S	OFF CAMP (5 Week Class - Starts 10/18/2010, Ends 11/19/2010)
8874	LEC 12:50 pm - 1:15 pm	F	INFANTE, M	CCW 259 (14 Week Class - Starts 9/11/2010, Ends 12/19/2010)
8881	LEC - 0:30 hrs	TBA	CORSO, M E	CCW 238 (10 Week Class - Starts 9/20/2010, Ends 11/22/2010)
8903	LEC - 0:40 hrs	TBA	HILL, V M	OFF CAMP (8 Week Class - Starts 9/10/2010, Ends 10/29/2010)
8907	LEC - 1:15 hrs	TBA	THOMPSON, A S	URBN LG (4 Week Class - Starts 9/9/2010, Ends 10/2/2010)
8912	LEC 12:05 pm - 12:15 pm	MTW	STAFF	CCW 258
8916	LEC - 0:50 hrs	TBA	STAFF	OFF CAMP (6 Week Class - Starts 11/1/2010, Ends 12/6/2010)
8920	LEC - 0:22 hrs	TBA	AMARO, A	CCW 246 (14 Week Class - Starts 9/13/2010, Ends 12/19/2010)
8924	LEC 2:25 pm - 2:40 pm	T Th	STAFF	CCW 255 (14 Week Class - Starts 9/13/2010, Ends 12/19/2010)

SECTION#	TIME	DAYS	INSTRUCTOR	LOCATION
8938	LEC 9:00 am - 2:55 pm	S	CORSO, M E	OFF CAMP
<i>(1 Week Class - Starts 11/5/2010, Ends 11/6/2010)</i>				

VOCATIONAL EDUCATION 237CE - STRATEGIES IN MEETING YOUR CUSTOMERS NEEDS (NDA) - 0.00 UNITS Rpt 9

8855	LEC - 1:20 hrs	TBA	CORSO, M E	OFF CAMP
<i>(5 Week Class - Starts 9/29/2010, Ends 10/30/2010)</i>				

VOCATIONAL EDUCATION 238CE - BLUEPRINT FOR WORKPLACE SUCCESS (NDA) - 0.00 UNITS Rpt 9

5700	LEC - 4:15 hrs	TBA	ARRELLANO, P E	OFF CAMP
<i>(8 Week Class - Starts 10/25/2010, Ends 12/19/2010)</i>				

5704	LEC 3:00 pm- 6:20 pm	MT	MARTI, K V	ARCH YEMP
AND	LEC 10:00 am -12:10 pm	S	MARTI, K V	ARCH YEMP
<i>(4 Week Class - Starts 11/1/2010, Ends 11/24/2010)</i>				

5726	LEC 2:00 pm - 4:30 pm	W	INFANTE, M	CCW 258
<i>(14 Week Class - Starts 9/11/2010, Ends 12/19/2010)</i>				

5729	LEC - 7:00 hrs	TBA	STAFF	SEIU INTE
<i>(5 Week Class - Starts 10/13/2010, Ends 11/13/2010)</i>				

5730	LEC - 3:05 hrs	TBA	INFANTE, M	SEIU INTE
<i>(11 Week Class - Starts 10/7/2010, Ends 12/19/2010)</i>				

5734	LEC - 3:20 hrs	TBA	SHISHIKYAN, A S	OFF CAMP
<i>(10 Week Class - Starts 10/13/2010, Ends 12/19/2010)</i>				

5735	LEC - 7:05 hrs	TBA	MARTI, K V	OFF CAMP
<i>(5 Week Class - Starts 10/11/2010, Ends 11/10/2010)</i>				

5741	LEC 9:00 am - 11:30 am	F	INFANTE, M	CCW 259
<i>(14 Week Class - Starts 9/11/2010, Ends 12/19/2010)</i>				

5743	LEC - 2:10 hrs	TBA	INFANTE, M	SEIU INTE
<i>(15 Week Class - Starts 9/11/2010, Ends 12/19/2010)</i>				

5745	LEC - 17:50 hrs	TBA	THOMPSON, A S	URBN LG
<i>(2 Week Class - Starts 12/6/2010, Ends 12/19/2010)</i>				

5746	LEC - 11:50 hrs	TBA	THOMPSON, A S	LA CNSC
AND	LEC - 11:50 hrs	TBA	THOMPSON, A S	LA CNSC
AND	LEC - 11:50 hrs	TBA	THOMPSON, A S	LA CNSC
<i>(1 Week Class - Starts 10/18/2010, Ends 10/22/2010)</i>				

5747	LEC - 3:20 hrs	TBA	JOHNSON, K S	TBA TBA
<i>(15 Week Class - Starts 9/6/2010, Ends 12/19/2010)</i>				

5748	LEC - 4:55 hrs	TBA	TORUNO, O	OFF CAMP
<i>(7 Week Class - Starts 11/1/2010, Ends 12/19/2010)</i>				

5814	LEC 4:00 pm - 6:20 pm	M W	EK, K	TBA TBA
<i>(7 Week Class - Starts 9/13/2010, Ends 10/30/2010)</i>				

5817	LEC 9:00 am - 1:15 pm	MTWTh	THOMPSON, A S	URBN LG
<i>(2 Week Class - Starts 10/4/2010, Ends 10/16/2010)</i>				

8717	LEC 10:00 am - 12:50 pm	Th	GARCIA, V A	TBA TBA
<i>(13 Week Class - Starts 9/17/2010, Ends 12/19/2010)</i>				

8736	LEC 9:00 am - 12:20 pm	S	INFANTE, M	CCW 259
<i>(10 Week Class - Starts 10/4/2010, Ends 12/19/2010)</i>				

8763	LEC - 2:00 hrs	TBA	WERBLE, D M	CCW 259
------	----------------	-----	-------------	---------

8773	LEC 8:00 am - 11:50 am	MTWThF	HILL, V M	JOB CORP
<i>(2 Week Class - Starts 8/30/2010, Ends 9/11/2010)</i>				

8776	LEC 8:00 am - 11:20 am	T Th	MARTI, K V	CCW 259
<i>(2 Week Class - Starts 9/6/2010, Ends 9/18/2010)</i>				

8777	LEC 8:00 am - 10:35 am	T Th	MARTI, K V	CCW 259
<i>(2 Week Class - Starts 9/20/2010, Ends 10/2/2010)</i>				

8779	LEC 3:00 pm - 5:25 pm	MT	MARTI, K V	ARCH YEMP
AND	LEC 10:00 am - 2:30 pm	S	MARTI, K V	ARCH YEMP
<i>(4 Week Class - Starts 9/27/2010, Ends 10/20/2010)</i>				

8781	LEC 8:00 am - 11:20 am	MTWThF	STAFF	JOB CORP
<i>(2 Week Class - Starts 10/11/2010, Ends 10/23/2010)</i>				

SECTION#	TIME	DAYS	INSTRUCTOR	LOCATION
8782	LEC 8:00 am - 11:20 am	MTWThF	HILL, V M	JOB CORP
<i>(2 Week Class - Starts 10/25/2010, Ends 11/6/2010)</i>				

8783	LEC 8:00 am - 11:50 am	MTWThF	HILL, V M	JOB CORP
<i>(2 Week Class - Starts 11/8/2010, Ends 11/19/2010)</i>				

8784	LEC 8:00 am - 12:15 pm	MTWThF	HILL, V M	JOB CORP
<i>(2 Week Class - Starts 11/22/2010, Ends 12/3/2010)</i>				

8858	LEC - 7:00 hrs	TBA	SHISHIKYAN, A S	OFF CAMP
<i>(5 Week Class - Starts 9/17/2010, Ends 10/17/2010)</i>				

8863	LEC - 7:00 hrs	TBA	STAFF	OFF CAMP
<i>(5 Week Class - Starts 10/18/2010, Ends 11/19/2010)</i>				

8867	LEC - 7:00 hrs	TBA	SHISHIKYAN, A S	OFF CAMP
<i>(5 Week Class - Starts 9/17/2010, Ends 10/17/2010)</i>				

8871	LEC 3:00 pm - 5:50 pm	F	COLON, N	SEIU INTE
<i>(13 Week Class - Starts 9/13/2010, Ends 12/13/2010)</i>				

8901	LEC 8:00 am - 11:20 am	MTWThF	HILL, V M	JOB CORP
<i>(2 Week Class - Starts 9/13/2010, Ends 9/25/2010)</i>				

8909	LEC 9:00 am - 11:30 am	MTWTh	THOMPSON, A S	URBN LG
<i>(4 Week Class - Starts 9/9/2010, Ends 10/2/2010)</i>				

8914	LEC 10:00 am - 12:50 pm	F	GARCIA, V A	TBA TBA
<i>(12 Week Class - Starts 9/20/2010, Ends 12/19/2010)</i>				

8918	LEC 4:00 pm - 6:10 pm	M W	STAFF	TBA TBA
<i>(8 Week Class - Starts 9/6/2010, Ends 10/30/2010)</i>				

8925	LEC - 5:00 hrs	TBA	STAFF	OFF CAMP
<i>(7 Week Class - Starts 10/10/2010, Ends 11/27/2010)</i>				

8940	LEC 8:00 am - 1:50 pm	F	CORSO, M E	AD 301B
<i>(6 Week Class - Starts 11/5/2010, Ends 12/17/2010)</i>				

8943	LEC 2:00 pm - 5:20 pm	T	STAFF	CCW 260
<i>(10 Week Class - Starts 8/30/2010, Ends 11/6/2010)</i>				

VOCATIONAL EDUCATION 239CE - BLUEPRINT FOR CUSTOMER SERVICE (NDA) - 0.00 UNITS Rpt 9

5702	LEC - 2:50 hrs	TBA	SHISHIKYAN, A S	CCW 259
<i>(6 Week Class - Starts 11/8/2010, Ends 12/19/2010)</i>				

5705	LEC - 2:05 hrs	TBA	INFANTE, M	SEIU INTE
<i>(8 Week Class - Starts 10/7/2010, Ends 11/27/2010)</i>				

5709	LEC 1:00 pm - 2:50 pm	MTWThF	STAFF	TBA TBA
<i>(2 Week Class - Starts 9/6/2010, Ends 9/17/2010)</i>				

5712	LEC - 1:05 hrs	TBA	COLON, N	SEIU INTE
<i>(14 Week Class - Starts 9/13/2010, Ends 12/19/2010)</i>				

5719	LEC - 7:30 hrs	TBA	STAFF	TBA TBA
<i>(2 Week Class - Starts 9/20/2010, Ends 10/2/2010)</i>				

5731	LEC - 1:00 hrs	TBA	INFANTE, M	SEIU INTE
<i>(15 Week Class - Starts 9/11/2010, Ends 12/19/2010)</i>				

5736	LEC - 3:20 hrs	TBA	MARTI, K V	OFF CAMP
<i>(5 Week Class - Starts 10/11/2010, Ends 11/10/2010)</i>				

5739	LEC 4:30 pm - 5:15 pm	T W	ARRELLANO, P E	TLP CHRC
<i>(10 Week Class - Starts 10/13/2010, Ends 12/19/2010)</i>				

5742	LEC 4:30 pm - 5:40 pm	W	INFANTE, M	CCW 259
<i>(14 Week Class - Starts 9/11/2010, Ends 12/19/2010)</i>				

5744	LEC - 3:20 hrs	TBA	STAFF	SEIU INTE
<i>(5 Week Class - Starts 11/15/2010, Ends 12/19/2010)</i>				

5810	LEC 6:25 pm - 7:30 pm	M W	EK, K	TBA TBA
<i>(8 Week Class - Starts 9/10/2010, Ends 10/30/2010)</i>				

5821	LEC 1:20 pm - 3:25 pm	MTWTh	THOMPSON, A S	URBN LG
<i>(2 Week Class - Starts 10/4/2010, Ends 10/16/2010)</i>				

5823	LEC - 17:50 hrs	TBA	STAFF	OFF CAMP
<i>(1 Week Class - Starts 10/25/2010, Ends 10/29/2010)</i>				

SECTION#	TIME	DAYS	INSTRUCTOR	LOCATION
5833	LEC 6:20 pm- 7:50 pm	M W F	STAFF	HOLL PRES
<i>(4 Week Class - Starts 11/1/2010, Ends 11/26/2010)</i>				
5836	LEC 3:30 pm- 6:50 pm	MTWThF	TORUNO, O	TBA TBA
<i>(1 Week Class - Starts 11/1/2010, Ends 11/6/2010)</i>				
8718	LEC 11:00 am - 11:35 am	T Th	STAFF	CCW 255
<i>(14 Week Class - Starts 9/13/2010, Ends 12/19/2010)</i>				
8739	LEC - 1:22 hrs	TBA	INFANTE, M	CCW 259
<i>(11 Week Class - Starts 10/4/2010, Ends 12/19/2010)</i>				
8760	LEC 12:30 pm - 1:25 pm	T	WILLIAMS, W P	OFF CAMP
8764	LEC - 0:55 hrs	TBA	STAFF	CCW 255
8769	LEC 8:00 am - 10:00 am	MTWThF	CALLERA, G P	JOB CORP
<i>(2 Week Class - Starts 8/31/2010, Ends 9/11/2010)</i>				
8832	LEC 2:30 pm - 6:45 pm	W	CORSO, M E	OFF CAMP
<i>(5 Week Class - Starts 9/27/2010, Ends 10/25/2010)</i>				
8833	LEC 1:50 pm - 3:55 pm	W	MARTI, K V	ARCH YEMP
<i>(8 Week Class - Starts 9/27/2010, Ends 11/24/2010)</i>				
8862	LEC 8:00 am - 10:05 am	F	STAFF	TBA TBA
<i>(8 Week Class - Starts 9/20/2010, Ends 11/14/2010)</i>				
8872	LEC 11:35 am - 12:45 pm	F	INFANTE, M	CCW 259
<i>(14 Week Class - Starts 9/11/2010, Ends 12/19/2010)</i>				
8886	LEC - 1:30 hrs	TBA	CORSO, M E	CCW 238
<i>(10 Week Class - Starts 9/20/2010, Ends 11/22/2010)</i>				
8887	LEC 8:00 am - 9:30 am	MTWThF	CALLERA, G P	JOB CORP
<i>(2 Week Class - Starts 9/13/2010, Ends 9/25/2010)</i>				
8889	LEC 8:00 am - 9:30 am	MTWThF	CALLERA, G P	JOB CORP
<i>(2 Week Class - Starts 9/27/2010, Ends 10/9/2010)</i>				
8891	LEC 8:00 am - 9:30 am	MTWThF	CALLERA, G P	JOB CORP
<i>(2 Week Class - Starts 10/11/2010, Ends 10/23/2010)</i>				

SECTION#	TIME	DAYS	INSTRUCTOR	LOCATION
8893	LEC 8:00 am - 9:30 am	MTWThF	CALLERA, G P	JOB CORP
<i>(2 Week Class - Starts 10/25/2010, Ends 11/6/2010)</i>				
8895	LEC 8:00 am - 9:50 am	MTWThF	CALLERA, G P	JOB CORP
<i>(2 Week Class - Starts 11/8/2010, Ends 11/20/2010)</i>				
8897	LEC 8:00 am - 10:20 am	MTWTh	STAFF	JOB CORP
<i>(2 Week Class - Starts 11/22/2010, Ends 12/4/2010)</i>				
8899	LEC 8:00 am - 9:30 am	MTWThF	STAFF	JOB CORP
<i>(2 Week Class - Starts 12/6/2010, Ends 12/19/2010)</i>				
8904	LEC - 2:00 hrs	TBA	HILL, V M	JOB CORP
<i>(8 Week Class - Starts 9/10/2010, Ends 10/29/2010)</i>				
8905	LEC 11:30 am - 12:40 pm	MTWTh	THOMPSON, A S	URBN LG
<i>(4 Week Class - Starts 9/9/2010, Ends 10/2/2010)</i>				
8913	LEC - 1:00 hrs	TBA	STAFF	CCW 258
8917	LEC - 1:00 hrs	TBA	JOHNSON, K S	TBA TBA
<i>(15 Week Class - Starts 9/6/2010, Ends 12/19/2010)</i>				
8921	LEC - 2:20 hrs	TBA	STAFF	TBA TBA
<i>(7 Week Class - Starts 11/1/2010, Ends 12/17/2010)</i>				
8941	LEC - 1:10 hrs	TBA	AMARO, A	CCW 246
<i>(13 Week Class - Starts 9/20/2010, Ends 12/19/2010)</i>				
8946	LEC 10:00 am - 2:15 pm	S	THOMPSON, A S	JOB CORP
<i>(5 Week Class - Starts 11/8/2010, Ends 12/17/2010)</i>				

VOCATIONAL EDUCATION 241CE - GET TO KNOW YOUR CUSTOMER (NDA) - 0.00 UNITS Rpt 9

8787	LEC - 0:38 hrs	TBA	CORSO, M E	CCW 259
<i>(8 Week Class - Starts 8/30/2010, Ends 10/23/2010)</i>				



VDK CAMPUS FALL 2010

SECTION # ROOM	COURSE	CLASS STARTS	CLASS ENDS	INSTRUCTOR	TIMES
MONDAY/WEDNESDAY CLASSES					
3046 VDK2-A110	Health 11	Mon Aug 30, 2010	Mon Oct 04, 2010	A GEVANYAN	6:00p-10:15p MW + Sat 9/18, 8:00a-5:00p
4901 VDK2-A110	English 101	Mon Oct 11, 2010	Wed Nov 10, 2010	STAFF	6:00p-10:15p MW + Sat 10/30, 8:00a-5:00p
4902 VDK2-A110	Anthro 101	Mon Nov 15, 2010	Wed Dec 15, 2010	STAFF	6:00p-10:15p MW + Sat 12/04, 8:00a-5:00p
TUESDAY/THURSDAY CLASSES					
3056 VDK2-A110	Speech 101	Tue Aug 31, 2010	Thur Sep 30, 2010	Y MAYO	6:00p-10:15p TTH + Sat 9/25 8:00a-5:00p
4921 VDK2-A110	Math 125	Tue Oct 5, 2010	Thur Dec 16, 2010	STAFF	6:00p-10:15p TTH (No TBA – only 5 SH)



LACCD Van de Kamp Innovation Center

Fall 2010



CLASS	STD Hours	DAYS	TIMES	INSTRUCTOR	DATES	SECTION
ESLCVCS Level 0	6	Mon/Wed	9:00am-1:00pm	Staff	Sept. 20 - Dec. 18	8750
ESLCVCS Level 1	6	Tue/Th	9:00am-1:00pm	Staff	Sept. 20 - Dec. 18	8751
Citizenship 012	3	Mon	9:00am-1:00pm	Arellano, P.	Sept. 20 - Dec. 18	8752
Citizenship 013	3	Fri	9:00am-1:00pm	Arellano, P.	Sept. 20 - Dec. 18	8944
Basic Comp.	3	Wed	9:00am-1:00pm	Marquez, R.	Sept. 20 - Dec. 18	8797

SHORT-TERM CLASSES

Career Advancement Academy (8wks) October 1st- November 24th

Math	2	TBA	1:00pm - 5:00pm	Staff	Oct. 1 - Nov. 24	5757
English	2	TBA	1:00pm - 5:00pm	Staff	Oct. 1 - Nov. 24	8740
Basic Comp.	3	TBA	1:00pm - 5:00pm	Staff	Oct. 1 - Nov. 24	5758
Job Readiness	3	TBA	1:00pm - 5:00pm	Corso	Oct. 1 - Nov. 24	8918/8718

October 4th - November 26th

ESL Beg. 1	3	M/T/W	6:00pm-8:00pm	Staff	Oct. 4 - Nov. 30	5759
ESL Beg. 2	3	M/T/W	6:00pm-8:00pm	Staff	Oct. 4 - Nov. 30	5760
Citizenship	3	M/T/W	6:00pm-8:00pm	Staff	Oct. 4 - Nov. 30	5820

EVENING CLASSES

ESLCVCS Level 0	6	Mon/Wed	6:00 pm - 9:00 pm	Staff	Sept. 20 - Dec. 18	5761
ESLCVCS Level 1	6	Tue/Th	6:00 pm - 9:00 pm	Staff	Sept. 20 - Dec. 18	5762
Citizenship 012	3	Mon	6:00 pm - 9:00 pm	Staff	Sept. 20 - Dec. 18	5763
Citizenship 013	3	Fri	6:00 pm - 9:00 pm	Staff	Sept. 20 - Dec. 18	5764
Basic Comp.	3	Thursdays	6:00 pm - 9:00 pm	Staff	Sept. 20 - Dec. 18	5765



LACC Fall 2010 Community Services Classes at VDK

Legal Secretary Certificate WorkShop

Computer Lab (RM107)
Tuesdays 6:00pm - 9:30pm
11/16/10 - 11/30/10

Microsoft Excel for Windows (Beginners)

Computer Lab (RM107)
Friday 9:30am - 3:30pm
11/12/10

Microsoft Excel Advanced

Computer Lab (RM107)
Friday 9:30am - 2:30pm
11/19/10

Selling Your Product on EBay

Computer Lab (RM107)
One - Monday & One Wednesday
6:00pm-8:00pm